

BOX RELÈ PRO

Potenza 25 Amp / Potenza 45 Amp

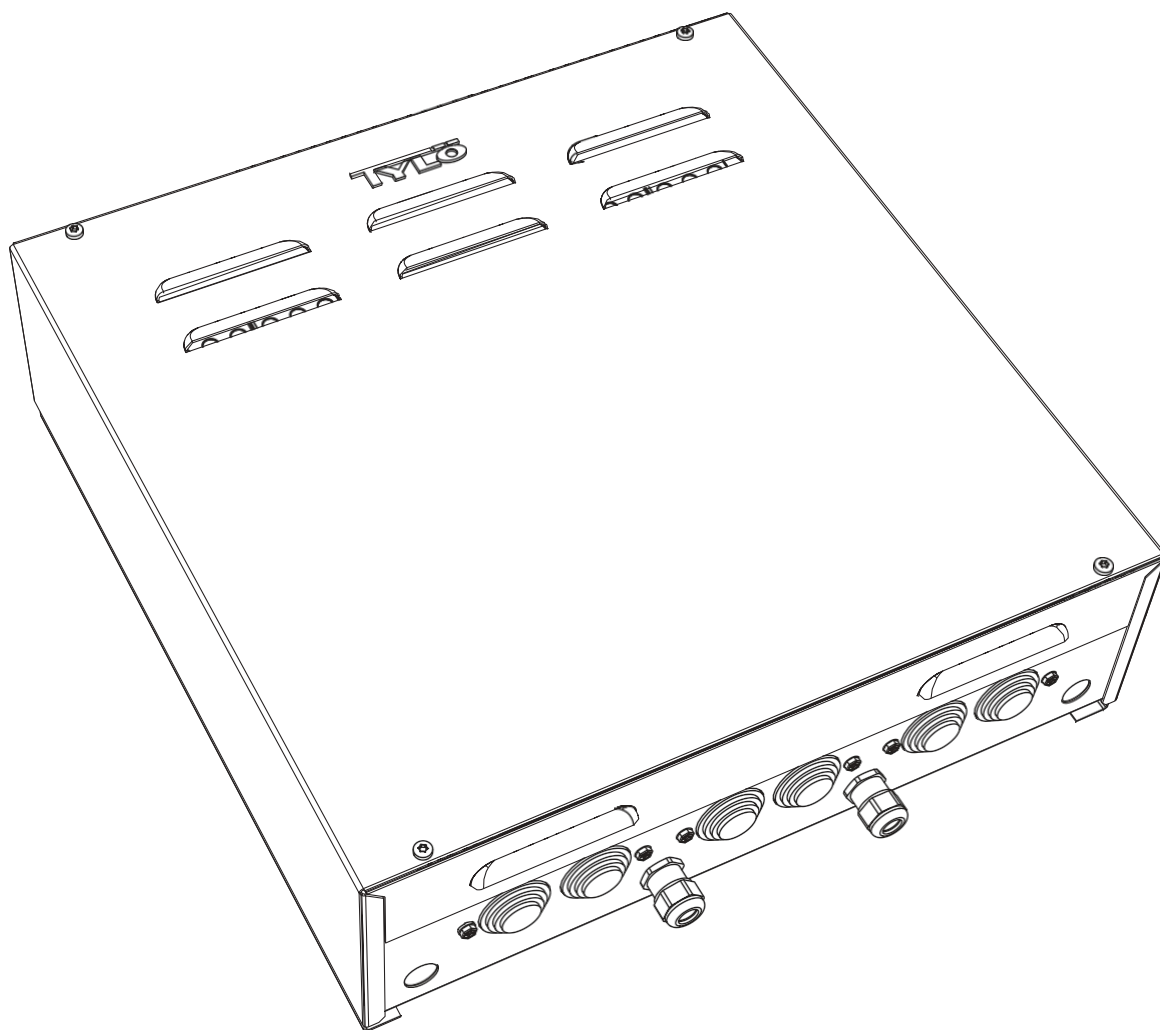

Parti

Verificare che le seguenti parti siano incluse nella confezione:

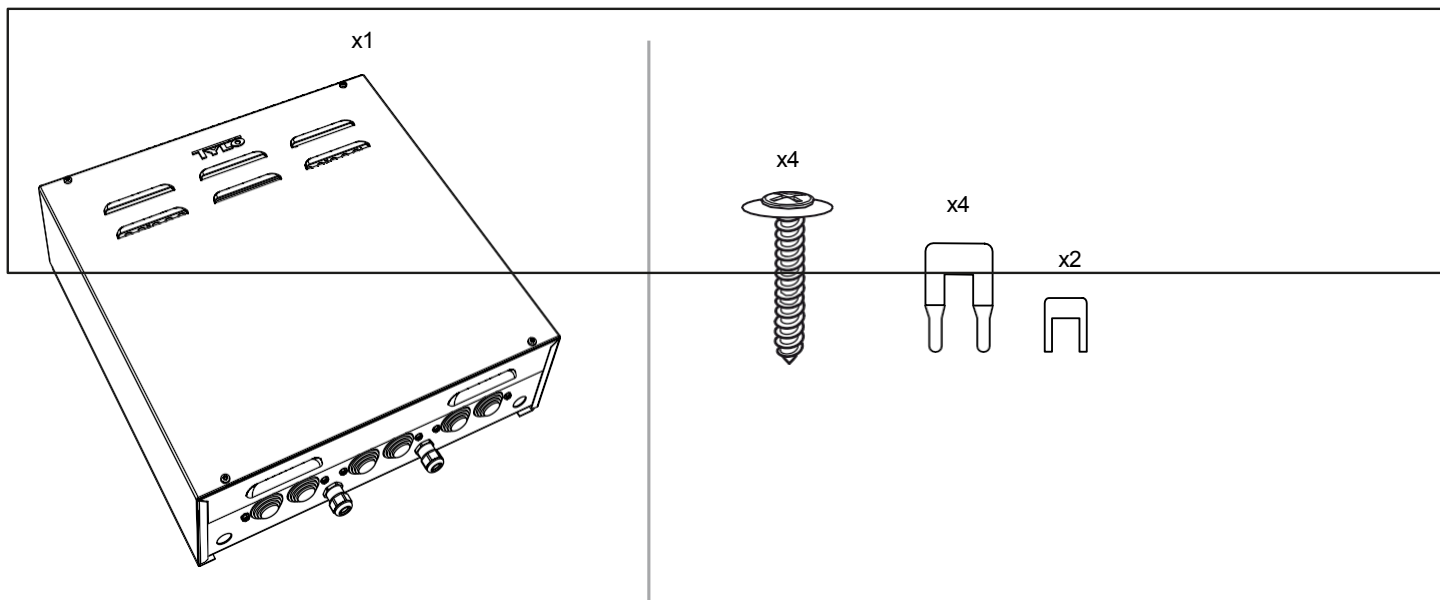

INSTALLAZIONE

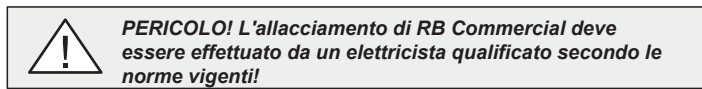

INSTALLAZIONE



Schema di collegamento

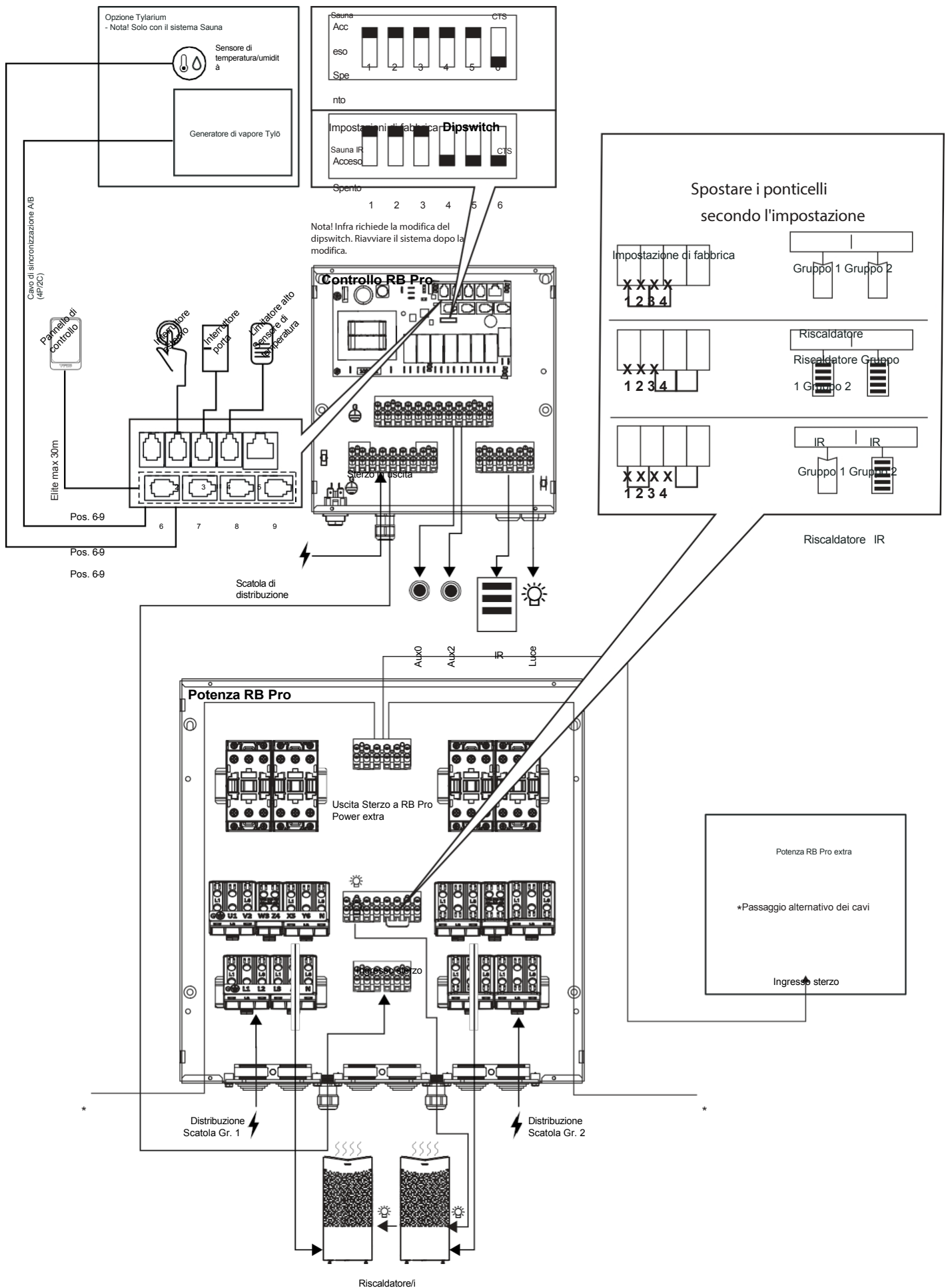

RB PRO POWER 25 AMP - 2 riscaldatori

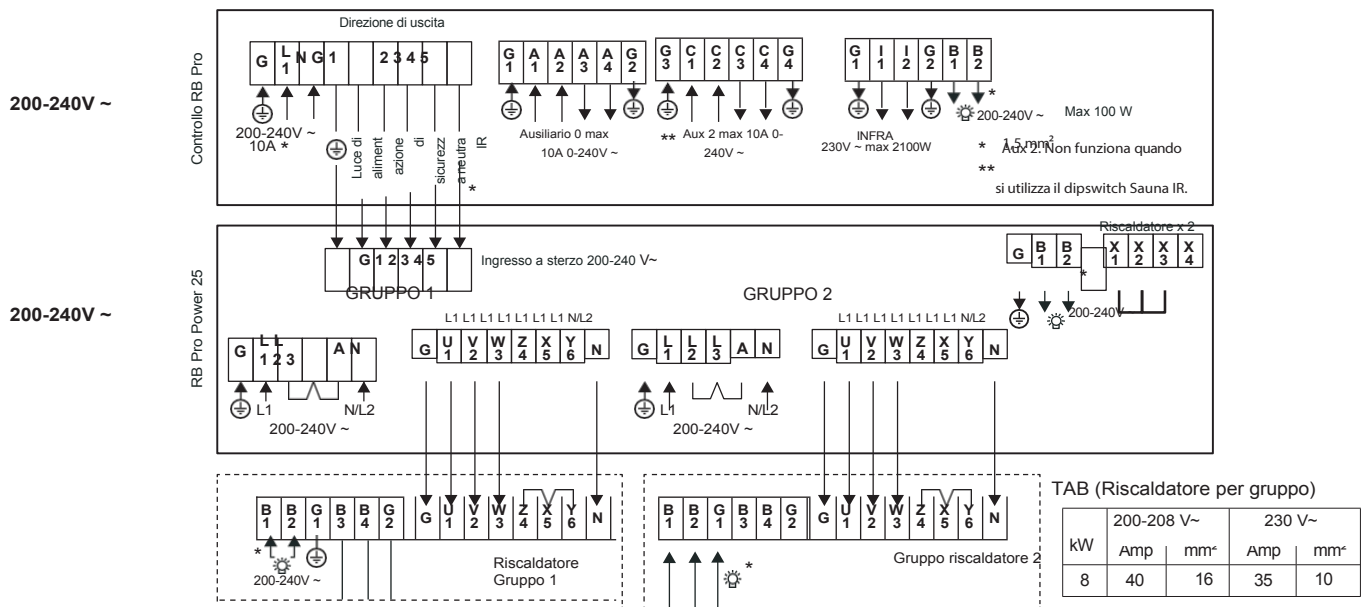
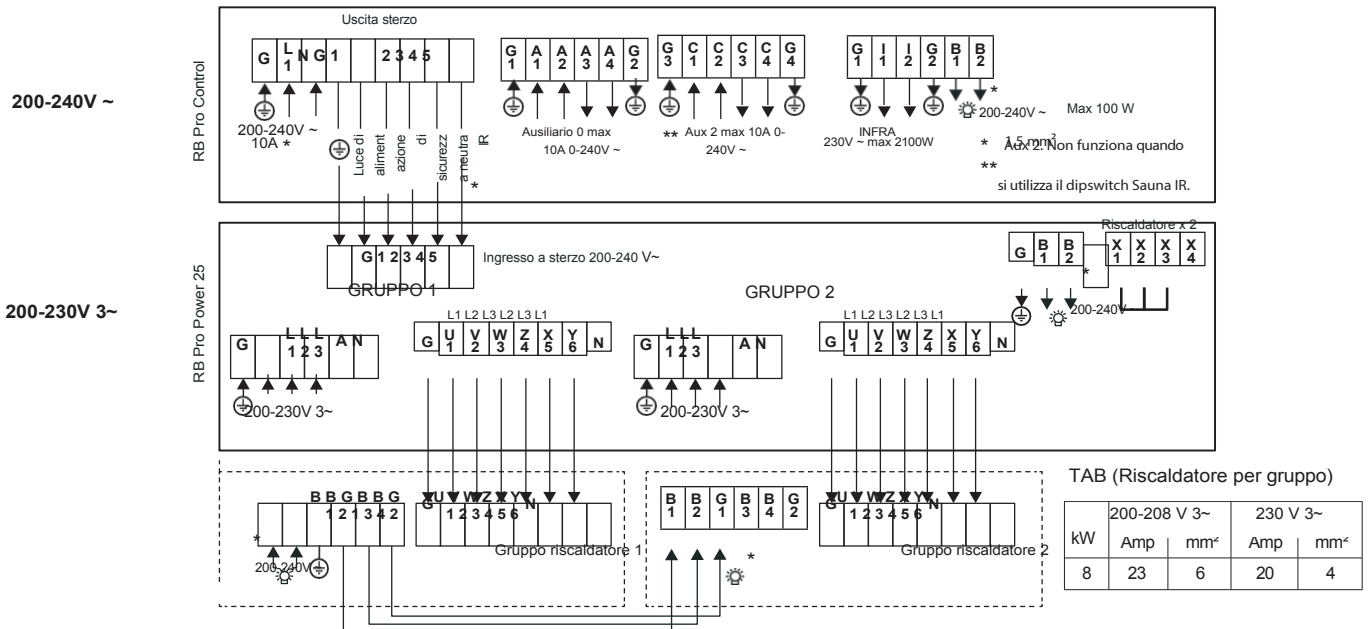
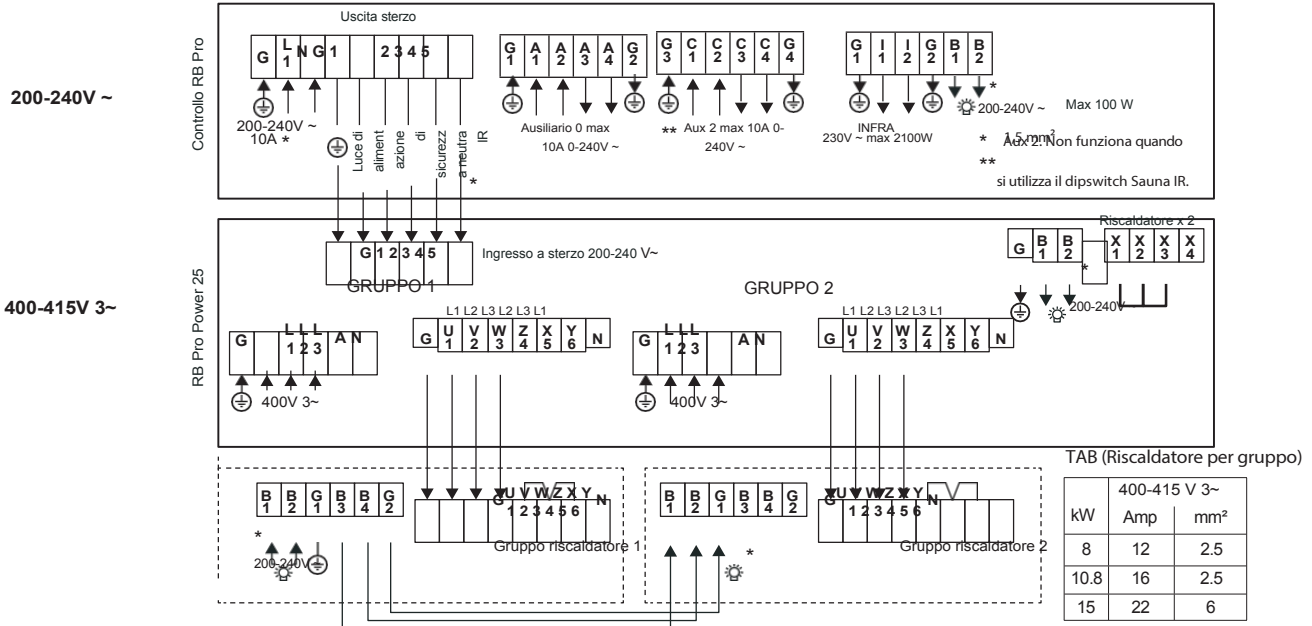

RB PRO POWER 25/45 AMP - Riscaldatore + IR

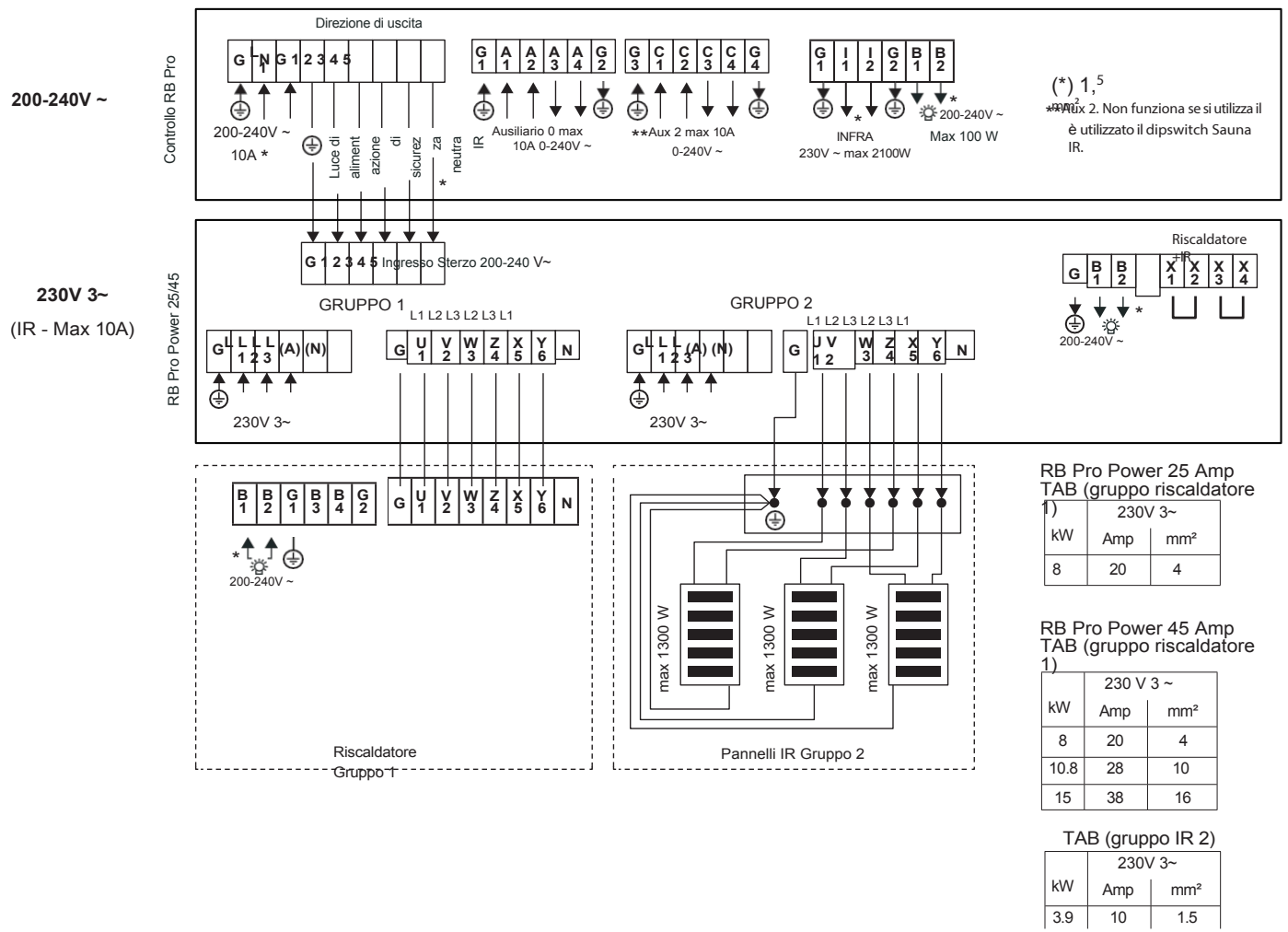
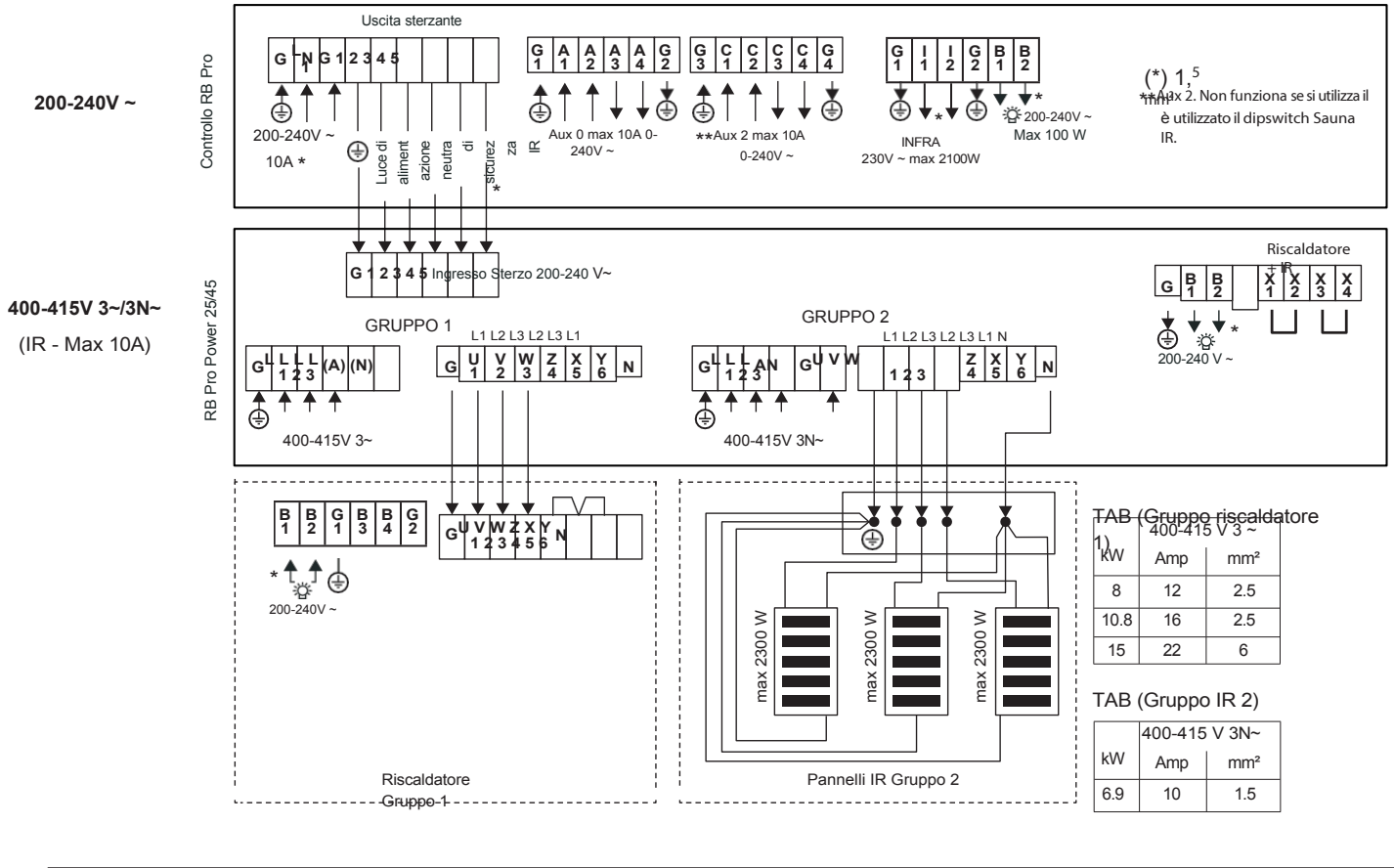

RB PRO POWER 25 AMP - 2xIR

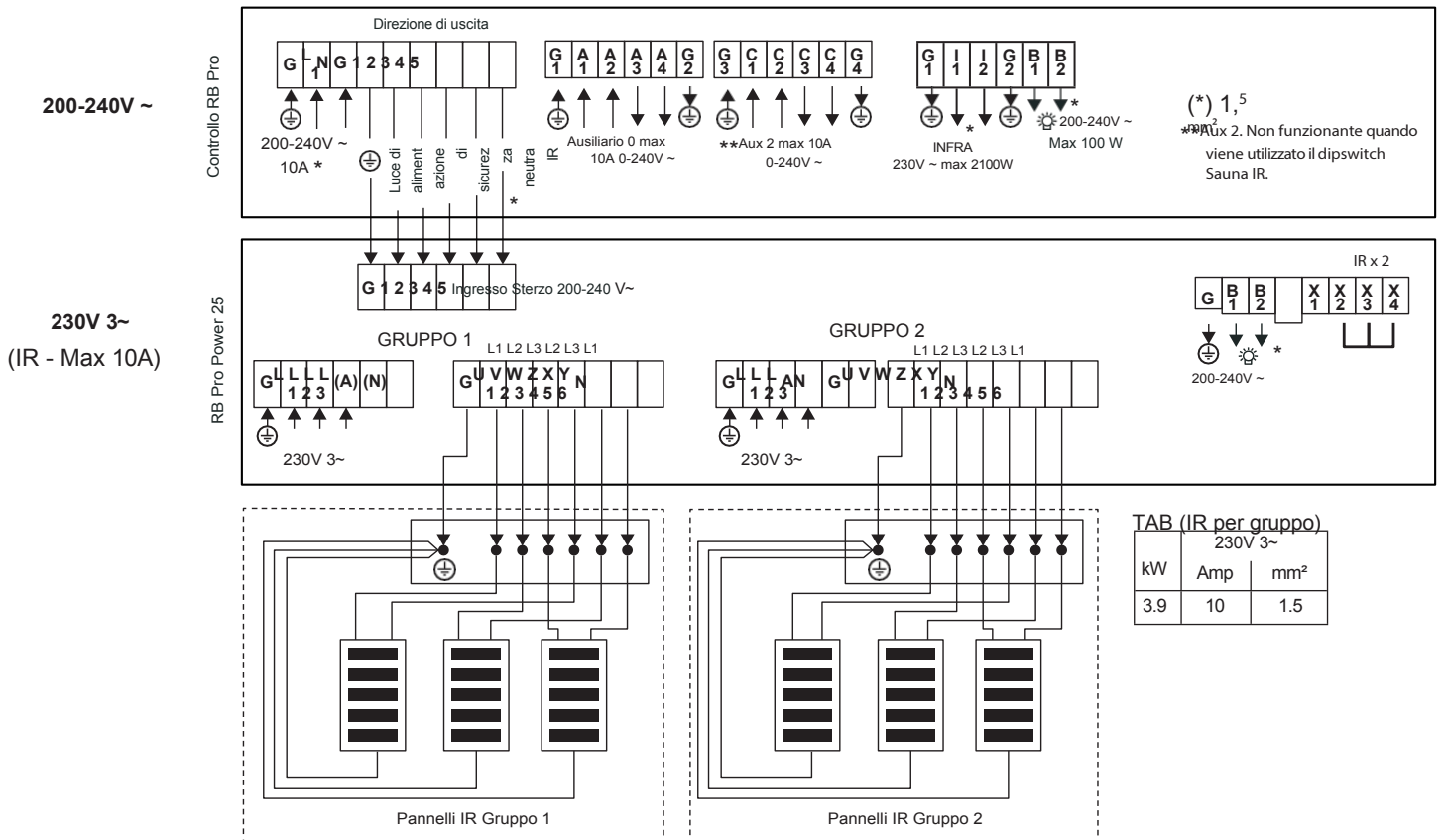
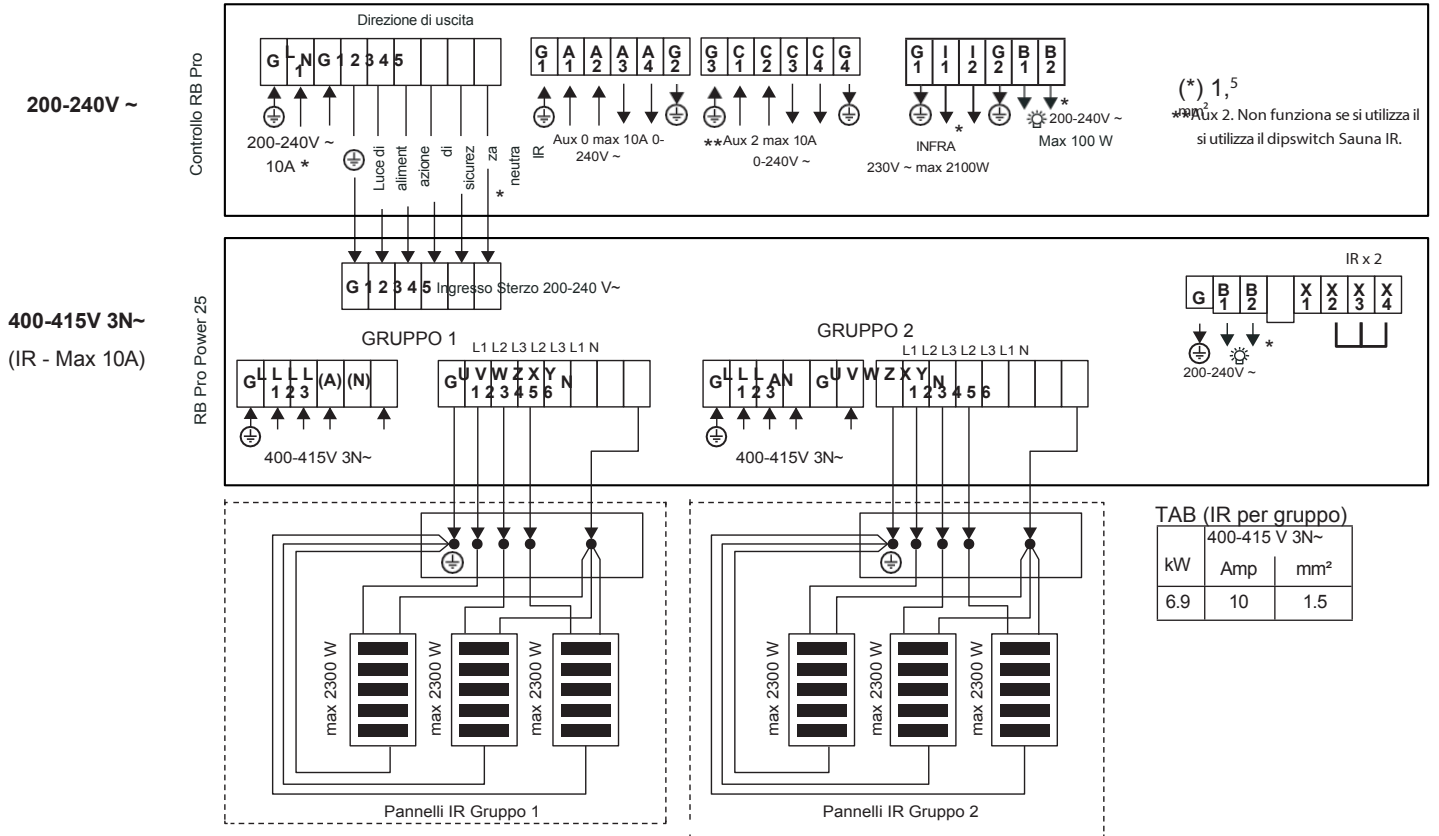

RB PRO POWER

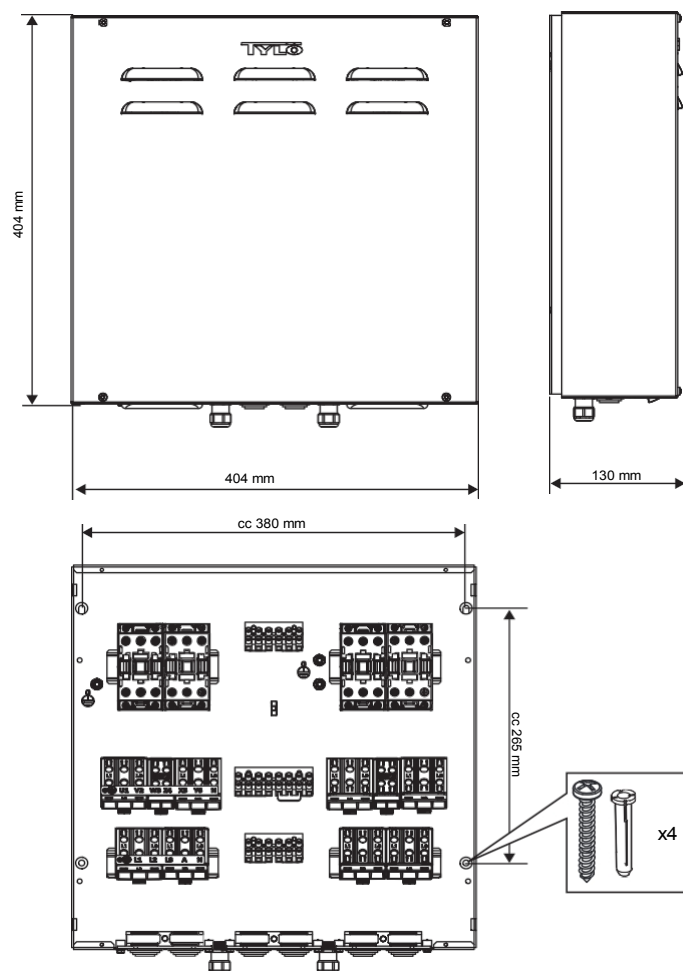

Collocazione

Montera RB Pro Control in ett torr och ventilerat utrymme. Temperatura massima di esercizio 35 gradi Celsius.

Posizionamento

Montare RB Pro Control in uno spazio asciutto e ventilato. Temperatura ambiente massima 35 gradi Celsius.

Montaggio

Montare RB Pro Control in un luogo asciutto e ben ventilato. Temperatura massima ambiente 35 gradi Celsius.

Installazione

Installare l'unità di controllo RB Pro Control in un luogo sicuro e ventilato. Temperatura ambiente massima: 35 °C.

Umiejscowienie

L'apparecchio RB Pro Control non deve essere sottoposto a umieścić in un luogo dove i valori di umidità sono bassi. La temperatura di esercizio è pari a 35 stopni Celsjusza.

Montaggio

Monteer RB Pro Control in un ambiente asciutto e protetto. Temperatura massima di funzionamento 35 gradi Celsius.

