

# Panacea 2521

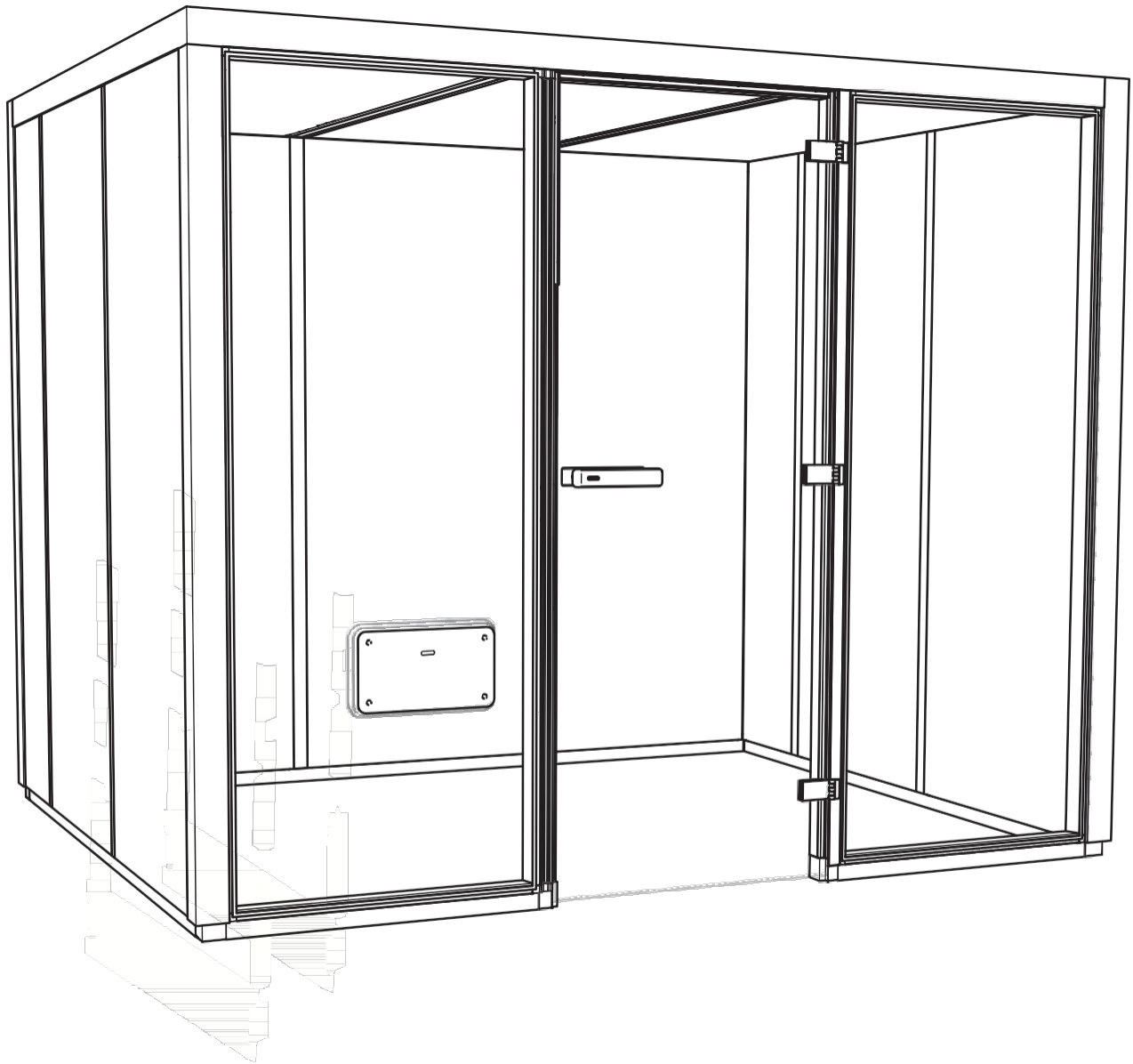

## Guida all'uso, bagno turco Tylö Panacea

### Informazioni generali:

Leggere attentamente questa guida prima di iniziare l'installazione.

La temperatura ambiente all'esterno del bagno turco non deve superare i 35° C. Non installare all'aperto per evitare il rischio di danni dovuti al freddo o al gelo.

La sauna vicina deve essere ben isolata con uno spazio ventilato di almeno 10 cm dal bagno turco.

Non esporre il materiale plastico del soffitto a sollecitazioni e non cercare di forzarlo.

Lasciare indurire la colla siliconica per almeno 24 ore prima di utilizzare il bagno turco.

### Pavimento:

Installare su un pavimento di piastrelle, marmo o stuoia di plastica completamente saldata, antiscivolo e resistente al calore.

Il pavimento deve avere una caduta per lo scarico, solitamente situata al centro del bagno turco. NB: Questo è importante quando si installa senza soglia. La caduta verso lo scarico deve iniziare all'esterno delle pareti del bagno turco.

Il pavimento sotto il telaio deve essere piano, uniforme e pulito.

Si consiglia il riscaldamento a pavimento per ridurre la differenza di temperatura nella stanza.

### Elettricità:

Illuminazione nel bagno turco max. 24 Volt.

Collegamento del generatore di vapore: vedere le istruzioni fornite con il generatore.

### Ventilazione:

Tutti i bagni di vapore in uso continuo per più di 2 ore devono avere un tasso di ricambio d'aria di 10-20 m<sup>3</sup> d'aria per persona all'ora, per motivi igienici e funzionali.

Lo spazio tra il fondo della porta e la soglia/pavimento consente l'ingresso dell'aria nel bagno turco.

La bocchetta di uscita deve essere posizionata nel soffitto, lontano dai posti a sedere, come indicato nella guida all'installazione. Lo sfiato di uscita deve essere collegato a un condotto di ventilazione per portare l'aria all'esterno.

Per i primi 8 metri dal bagno turco, il condotto di ventilazione deve essere in plastica o altro materiale resistente alla corrosione in grado di tollerare un'elevata umidità dell'aria. L'installazione del condotto di ventilazione

deve evitare la formazione di sacche d'acqua dovute alla condensa, che causano un'ostruzione. Il condotto di ventilazione deve essere assolutamente sigillato, senza fori o fessure da cui possano fuoriuscire vapore o acqua.

### Estrazione meccanica:

Se la ventilazione di estrazione fornita dal principio della ventilazione naturale è insufficiente (può essere dovuta alla bassa pressione nella stanza da cui l'aria viene fornita al bagno turco), è necessario collegare una ventilazione meccanica dimensionata per 10-20 m<sup>3</sup> per persona all'ora.

### Installazione di docce, profumatori e dispositivi di pulizia nel bagno turco:

Installare tubi e raccordi durante l'installazione del bagno turco.

### Ispezione:

Ispezionare tutte le sezioni per verificare la presenza di eventuali danni al momento del disimballaggio.

### Cosa fare:

I danni materiali devono essere segnalati immediatamente al fornitore. Se è necessario sostituire una sezione, ritardare l'installazione fino a quando non sarà disponibile una nuova sezione.

Non ci si assume alcuna responsabilità per i danni causati o per eventuali costi conseguenti durante il trasporto o l'installazione.

### Pulizia:

Sciquare gli accessori e il pavimento dopo ogni utilizzo.

Per mantenere l'igiene del bagno turco, il pavimento (soprattutto negli angoli e sotto gli apparecchi) deve essere pulito regolarmente con un detergente antibatterico. Utilizzare il disinfettante Tylö.

Per la pulizia di tutte le superfici delle pareti e del soffitto si può utilizzare acqua saponata delicata.

Il set di pulizia per Corian di Tylö è consigliato per i banchi in Corian.

Non utilizzare polvere abrasiva, detersivi alcalini forti, solventi aggressivi, idropultrici ecc. In caso di dubbi sulla rimozione delle macchie, contattare Tylö.

Il dispositivo di pulizia Tylö Steam Clean è consigliato per la pulizia e la disinfezione quotidiana. Funziona automaticamente ed è dotato di una chiusura a combinazione.

### Garanzia sui materiali:

La garanzia sui materiali fornita per i bagni a vapore Tylö è subordinata al rispetto delle istruzioni del produttore.

### Importante!

Utilizzare sempre il silicone fornito da Tylö.

Lasciare indurire la colla al silicone per almeno 24 ore prima di utilizzare il bagno turco.

Non esporre il materiale plastico del soffitto a sollecitazioni. Non premere o forzare le sezioni in posizione.

Non esporre il bagno turco a temperature superiori a 55° C.

**Non collocare mai apparecchi o altri oggetti direttamente davanti o sopra l'ugello del vapore. Mantenere sempre uno spazio libero di almeno 20 cm davanti all'ugello del vapore, vedere il diagramma.**

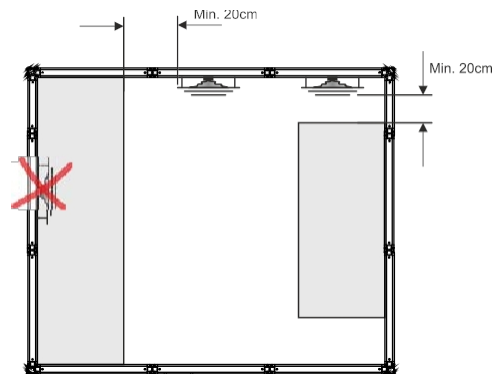

Utilizzare solo i profumi e i disinfettanti Tylö. Altri prodotti possono causare danni.

Non utilizzare un'idropulitrice per la pulizia.

Qui sono mostrati due esempi di montaggio della stanza. Le presenti istruzioni di montaggio e installazione descrivono la procedura di assemblaggio della Stanza 1. I numeri indicano l'ordine di montaggio delle pareti. Gli schemi di layout utilizzano i seguenti codici per indicare i materiali/componenti: A= vetro verde, B= vetro, C= vetro nero/vetro verde, D= porta in vetro, E= sezione vapore.

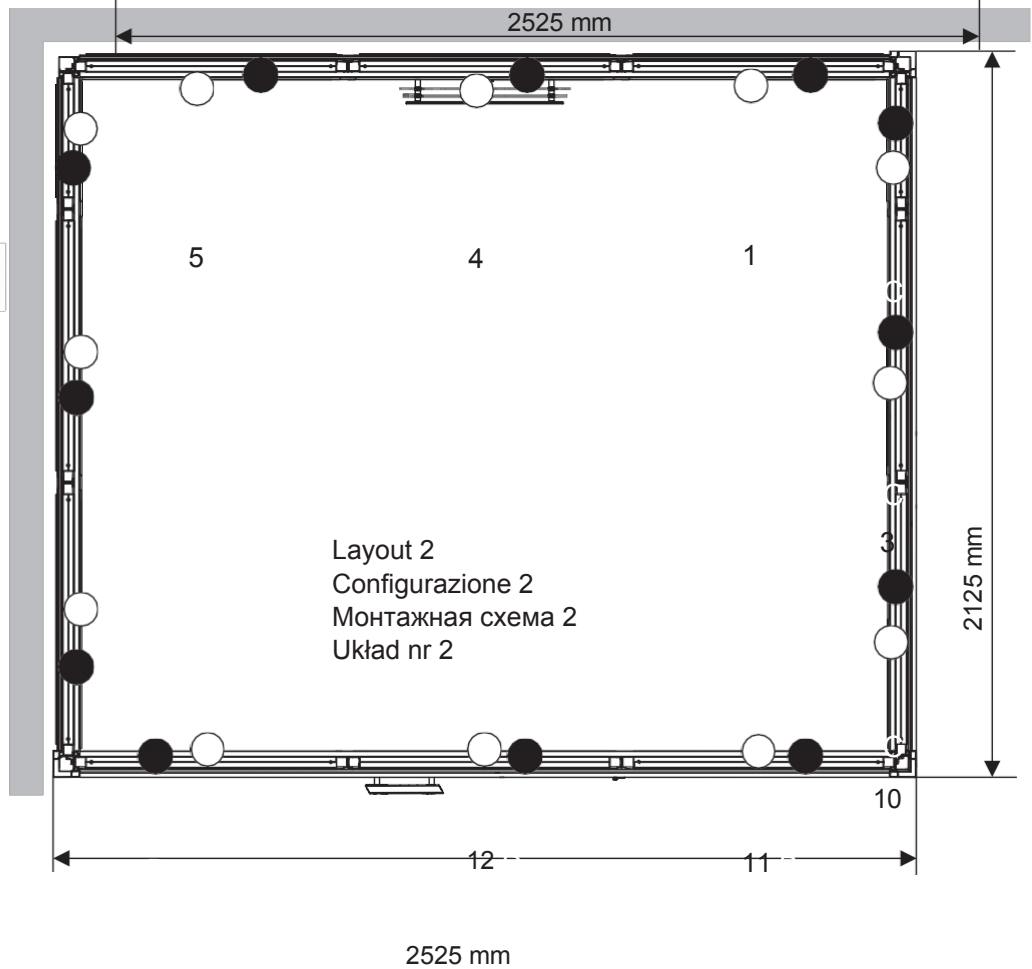
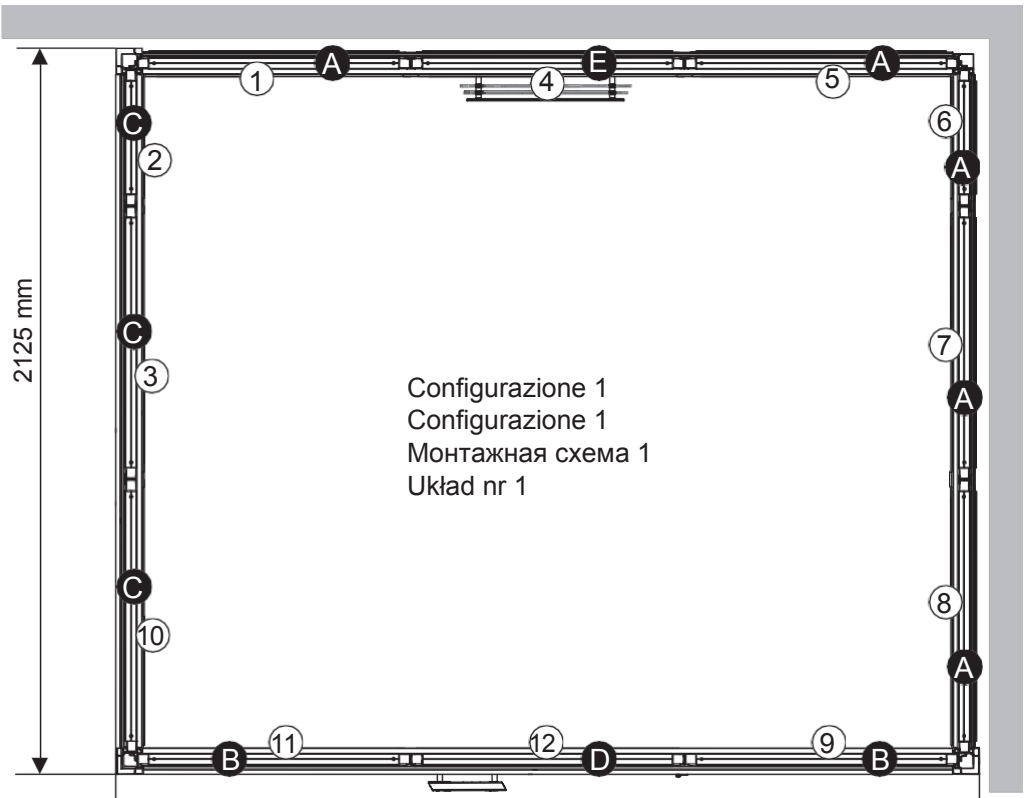

- Min. 2400 mm - Vid monterig
- Min. 2400 mm - Durante il montaggio/installazione
- Mente. 2400 mm - Montaggio Bei
- Mini. 2400 mm - Durante il montaggio
- Мин. 2400 мм - При монтаже
- Min. 2400 mm - Dimensioni minime del corpo

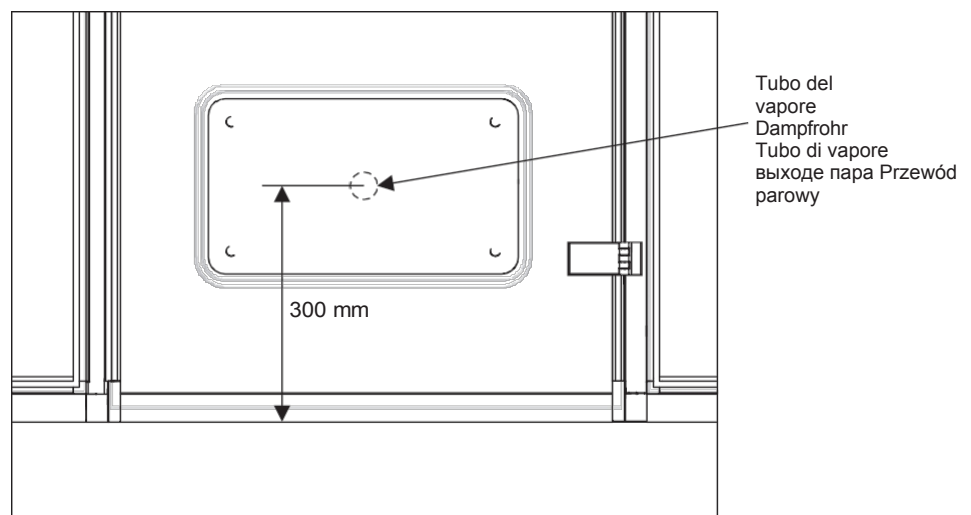
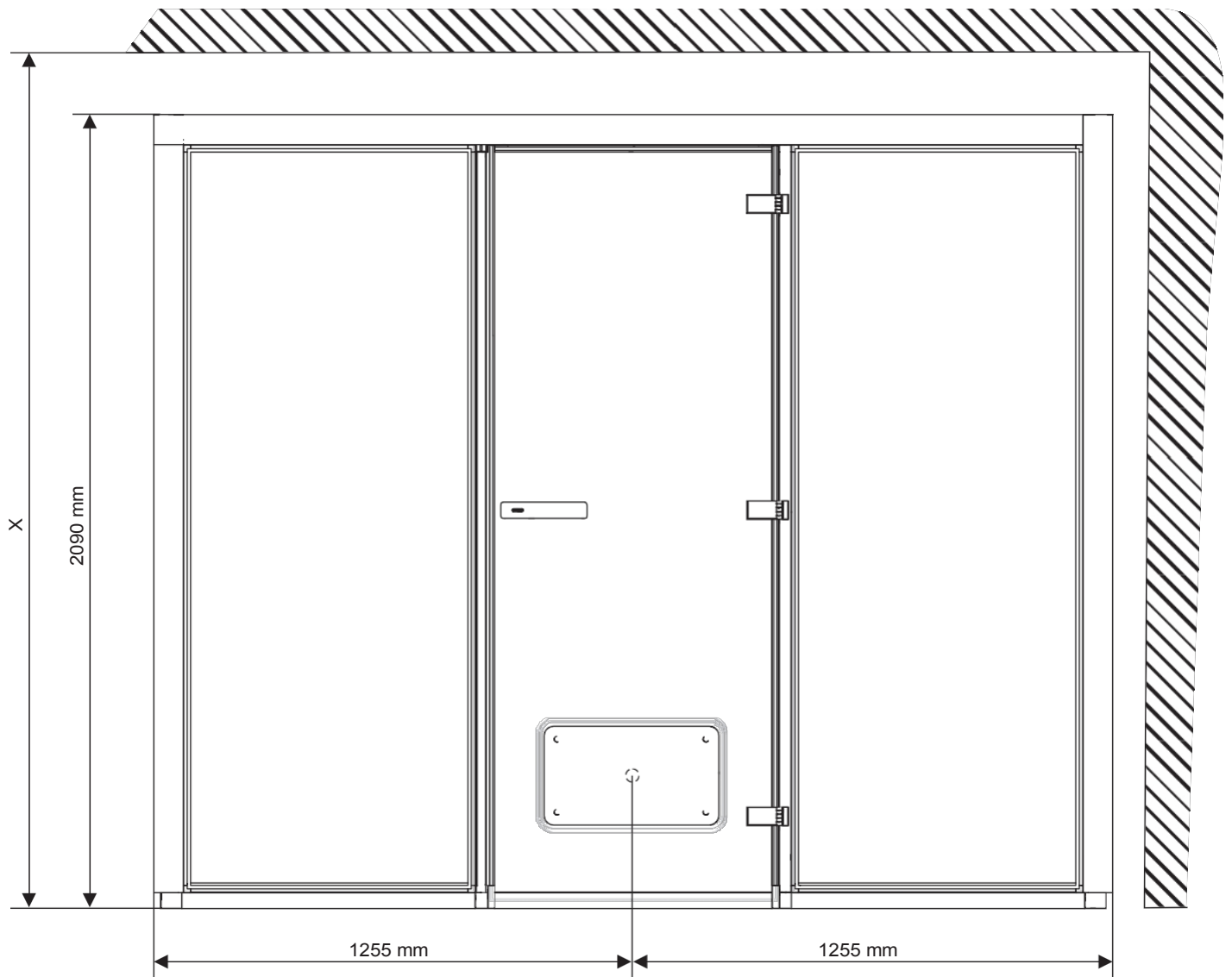

Golv / Golvrám  
Pavimento / Telaio  
del pavimento  
Boden / Bodenrahmen  
Sol / Cadre de sol Пол /  
Рамы пола  
Posadzka / Ramy podłogowej

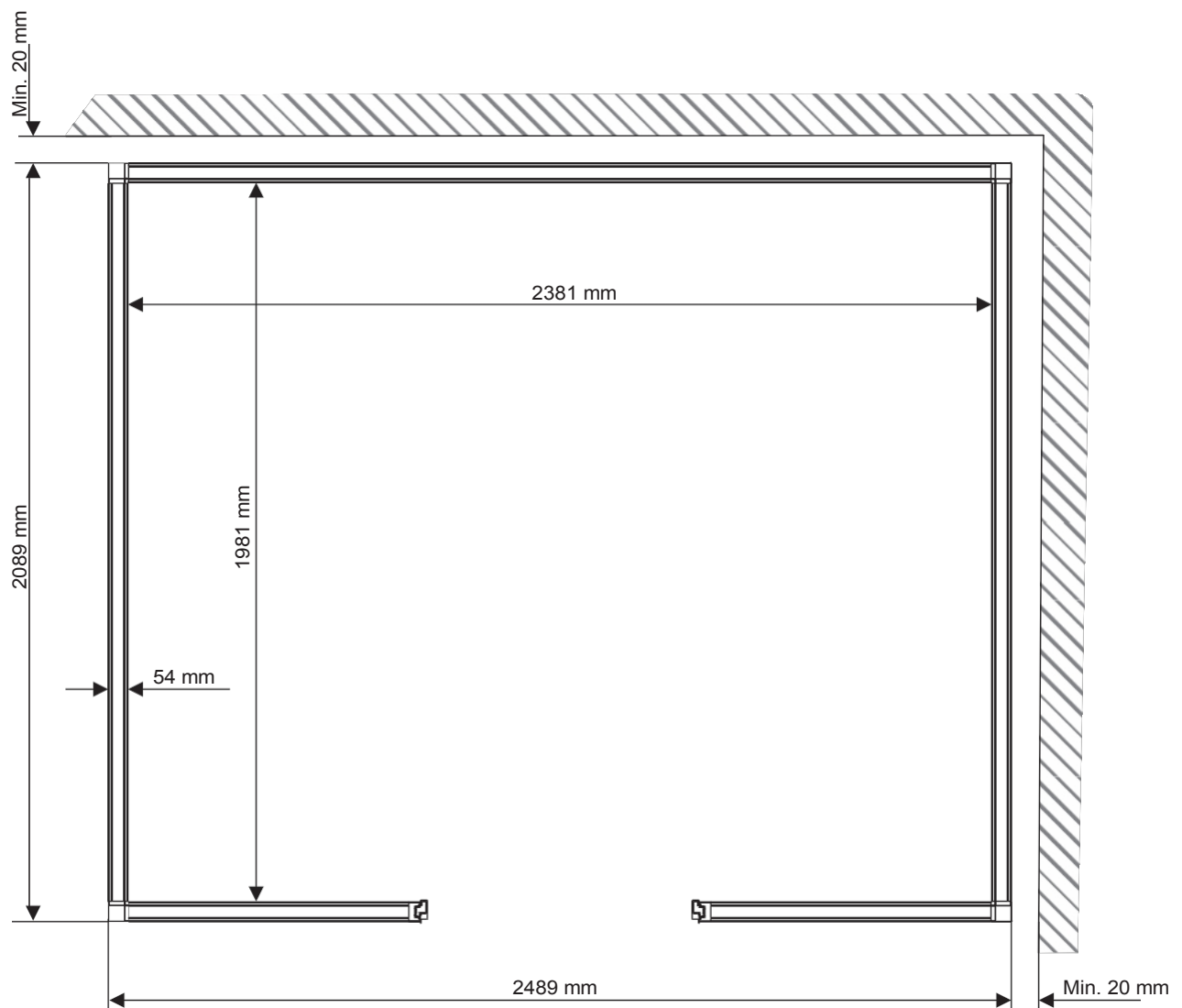
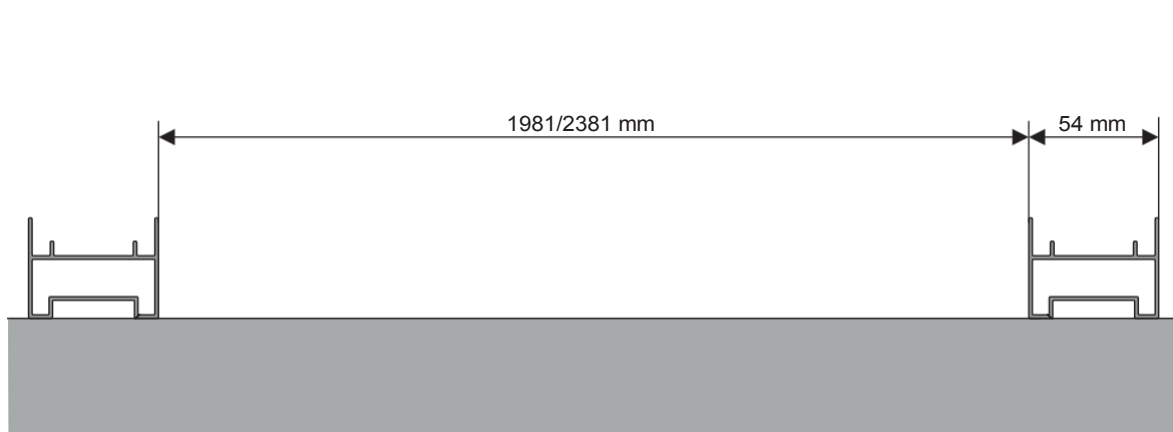

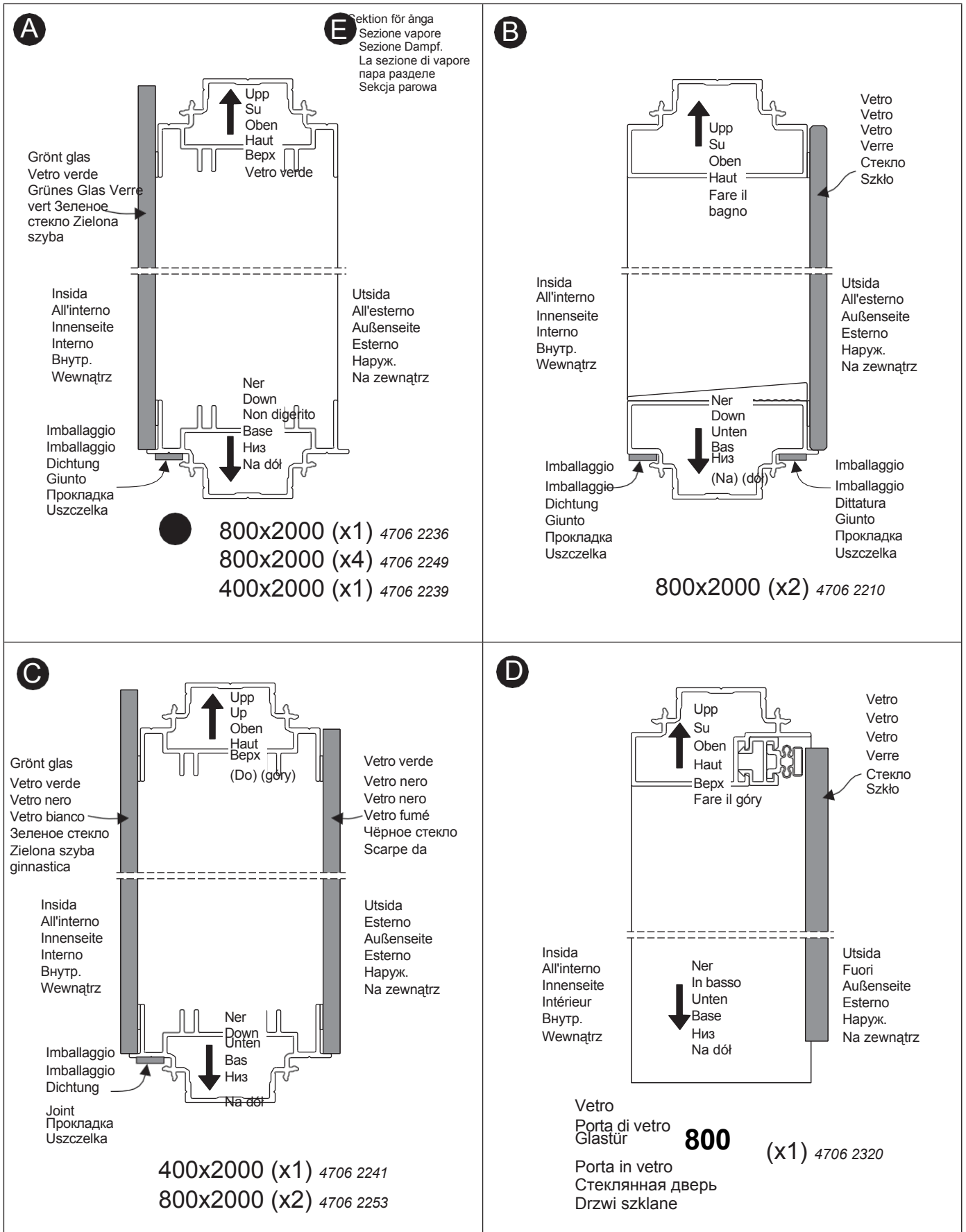

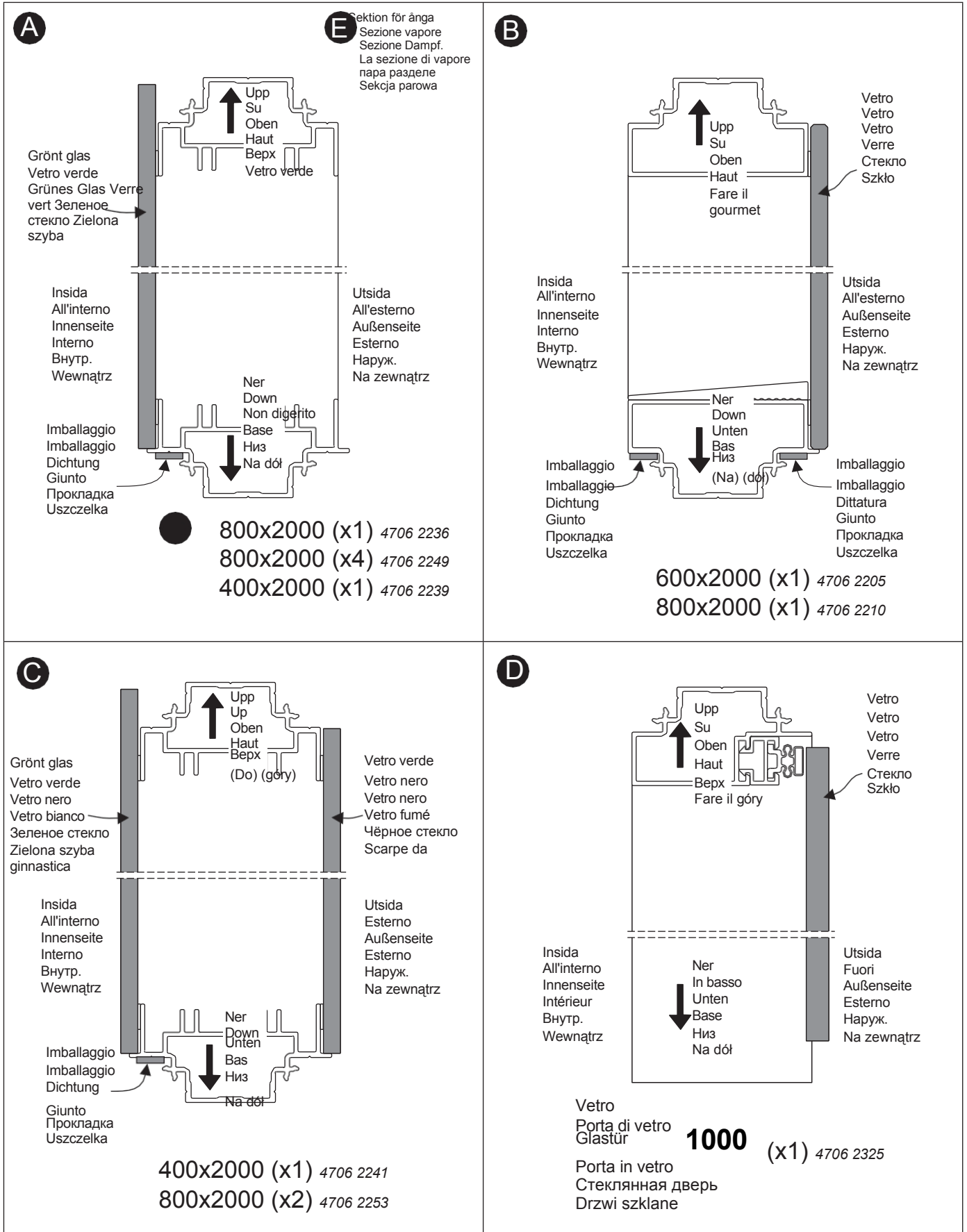

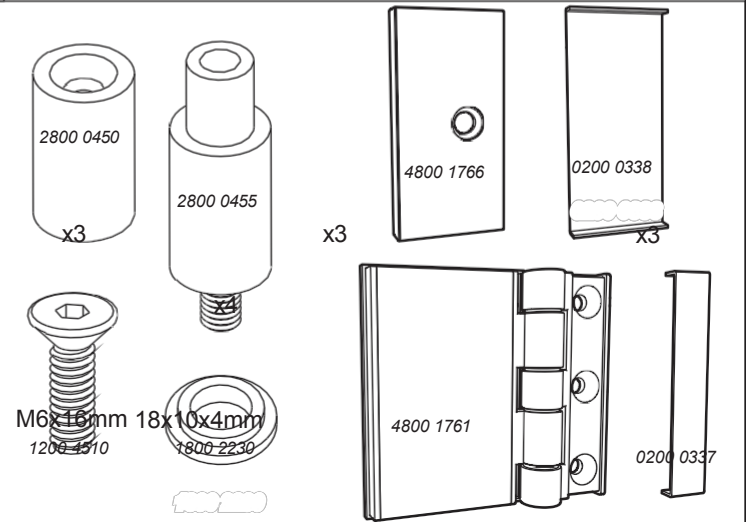
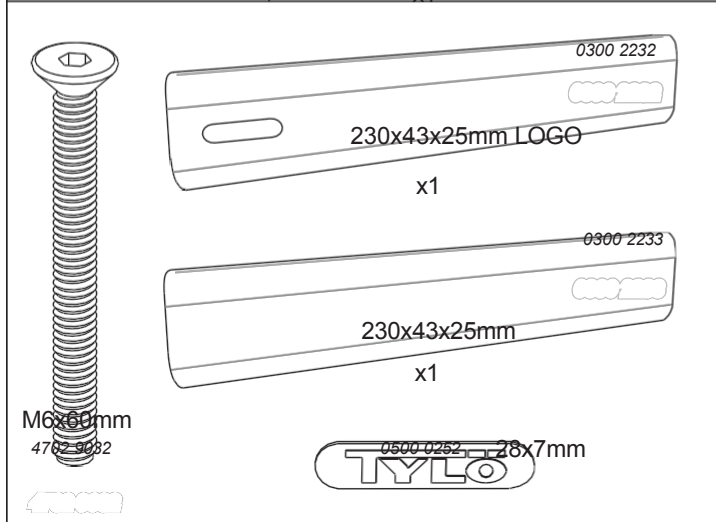
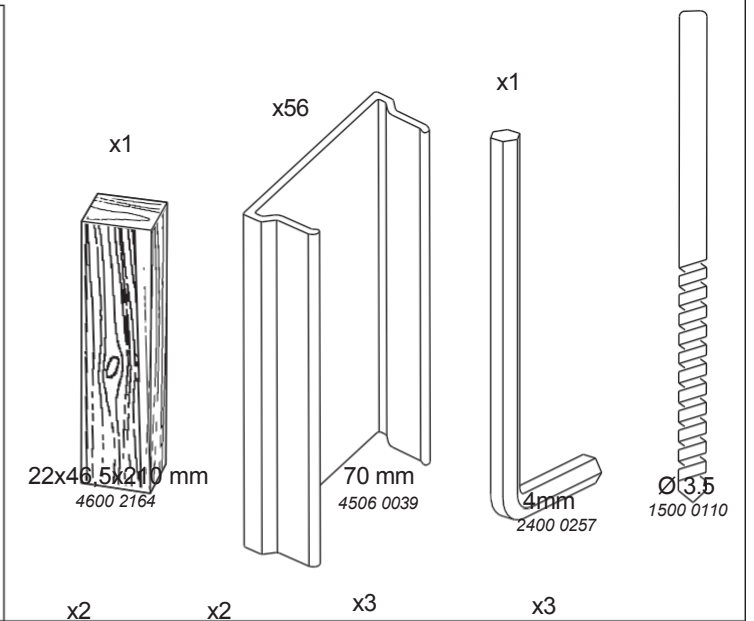
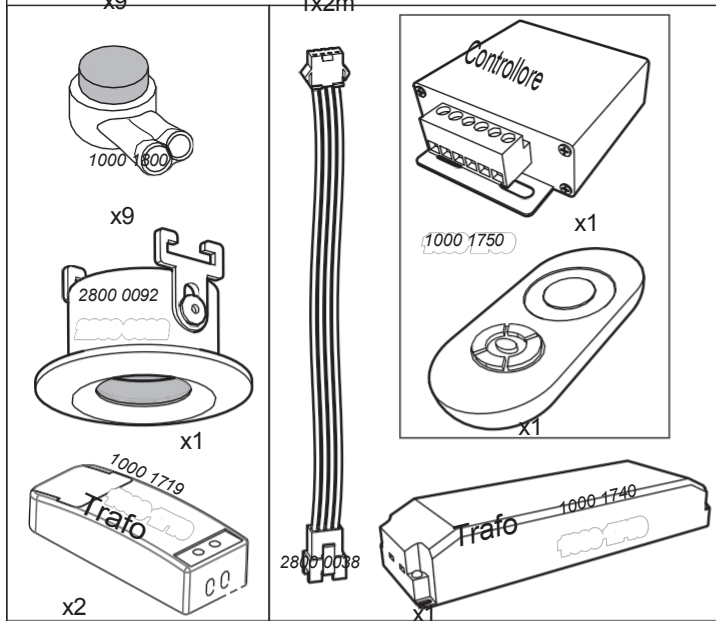
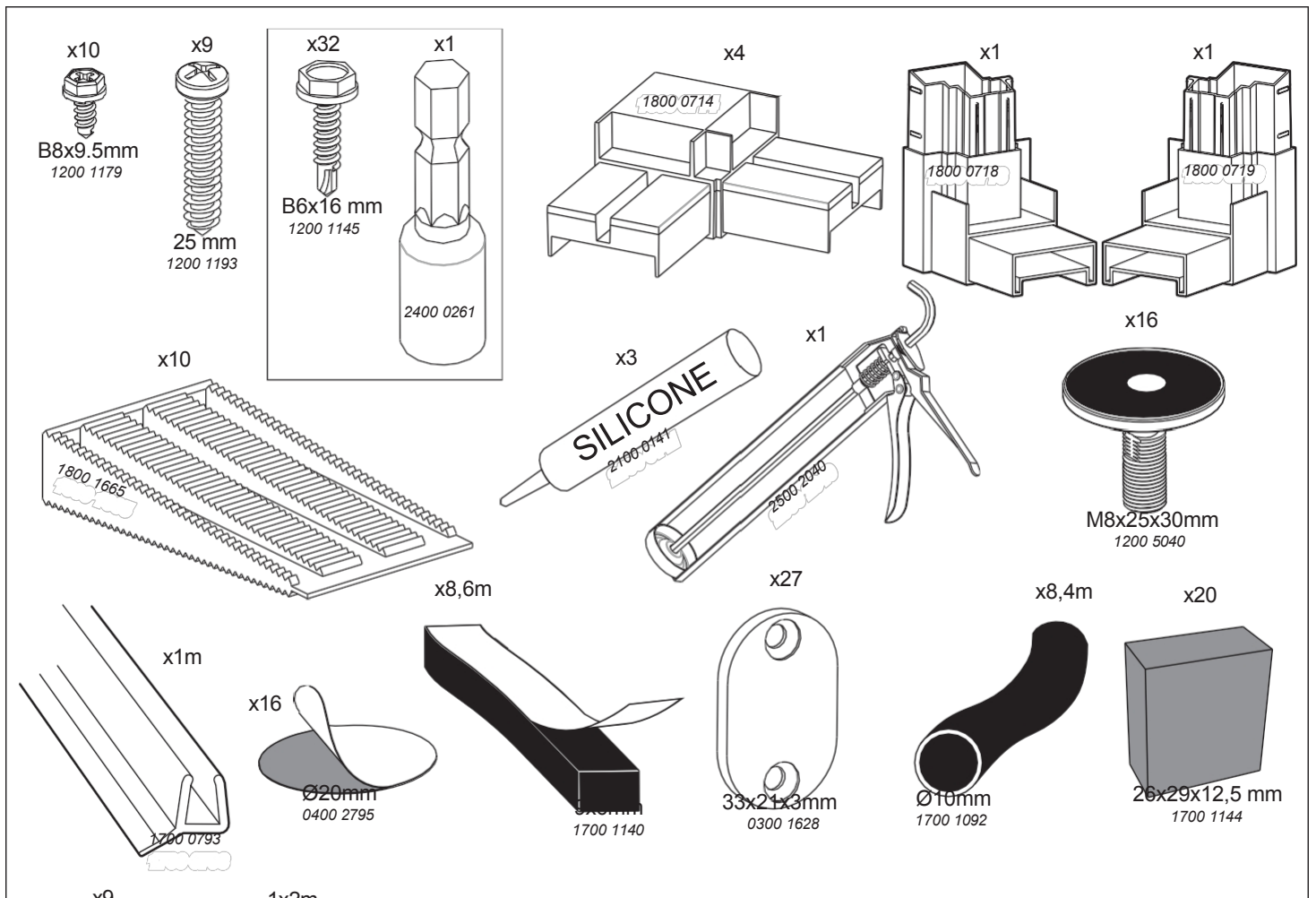

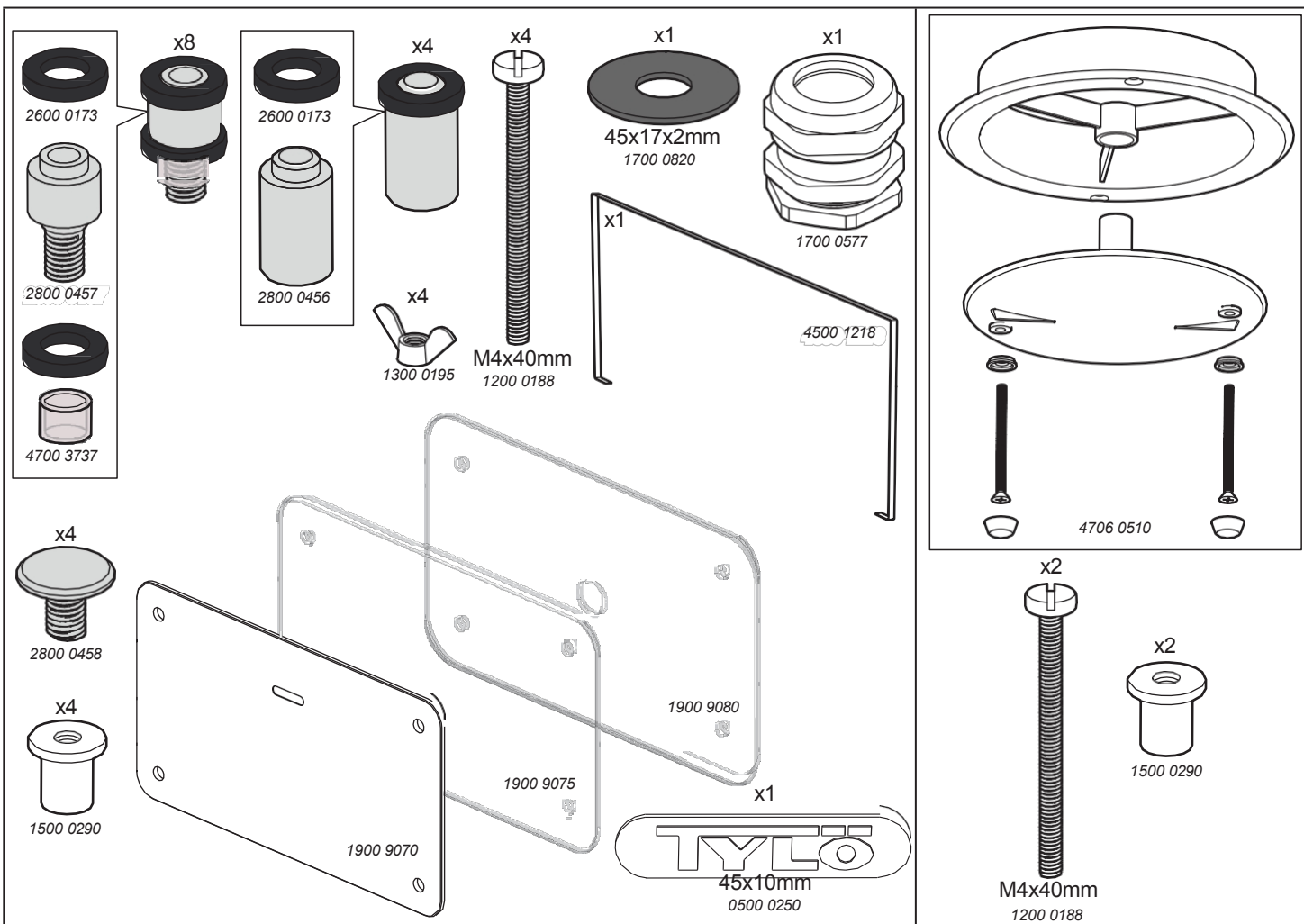

Profiler / Profili / Profilo / Perfilés / Рейки / Profilo

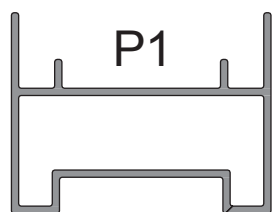

Porta 800:

2x772,5mm 4506 0093

2x1977mm 4506 0095

1x2377mm 4506 0096

Porta 1000:

1x572,5mm 4506 0097

(1x772,5mm) (4506) (0093)

(2x1977mm) (4506) (0095)

(1x2377mm) (4506) (0096)

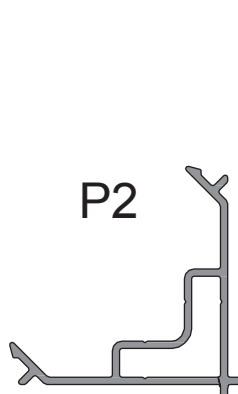

4x1930mm 4506 0060

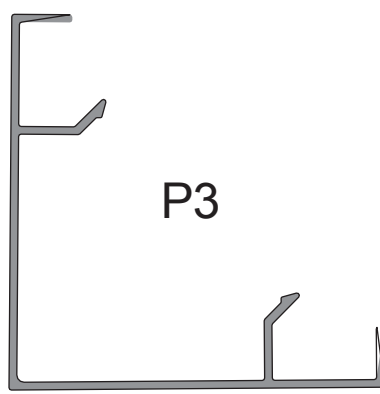

2x2048mm 4506 0179



1x2046mm V/L 1x2446mm V/L

4506 0209

4506 0214

1x2046mm H/R 1x2446mm H/R

4506 0208

4506 0213

P13

Porta 800:

1x765mm

4506 0832

Porta 1000:

1x965mm

(4506) (0830)

P5



2x1168 mm 4506 0046

9x1968mm 4506 0050

P6



2x1968 mm 4506 0150

2x2368 mm 4506 0152

P7



1x1949mm 4506 0796

P8



3x1968 mm 4606 0650

P9



1x1968 mm 4606 0653

P10



5x1980mm 4606 0662

P10-T

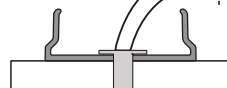

1x1980mm 4606 0663

(4m)

P11



2x1962,5 mm 4506 0690

P12



(1x1968mm) (4606) (0654)

Utensili utili, ecc.

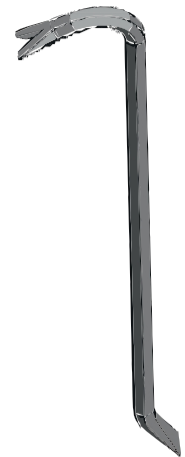
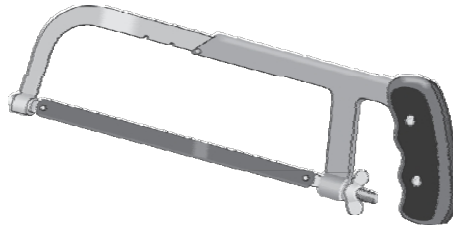

# 1 Montaggio del telaio a pavimento

Glasdörr  
Porta in  
vetro  
Glastür  
Porte vitrée

# 800

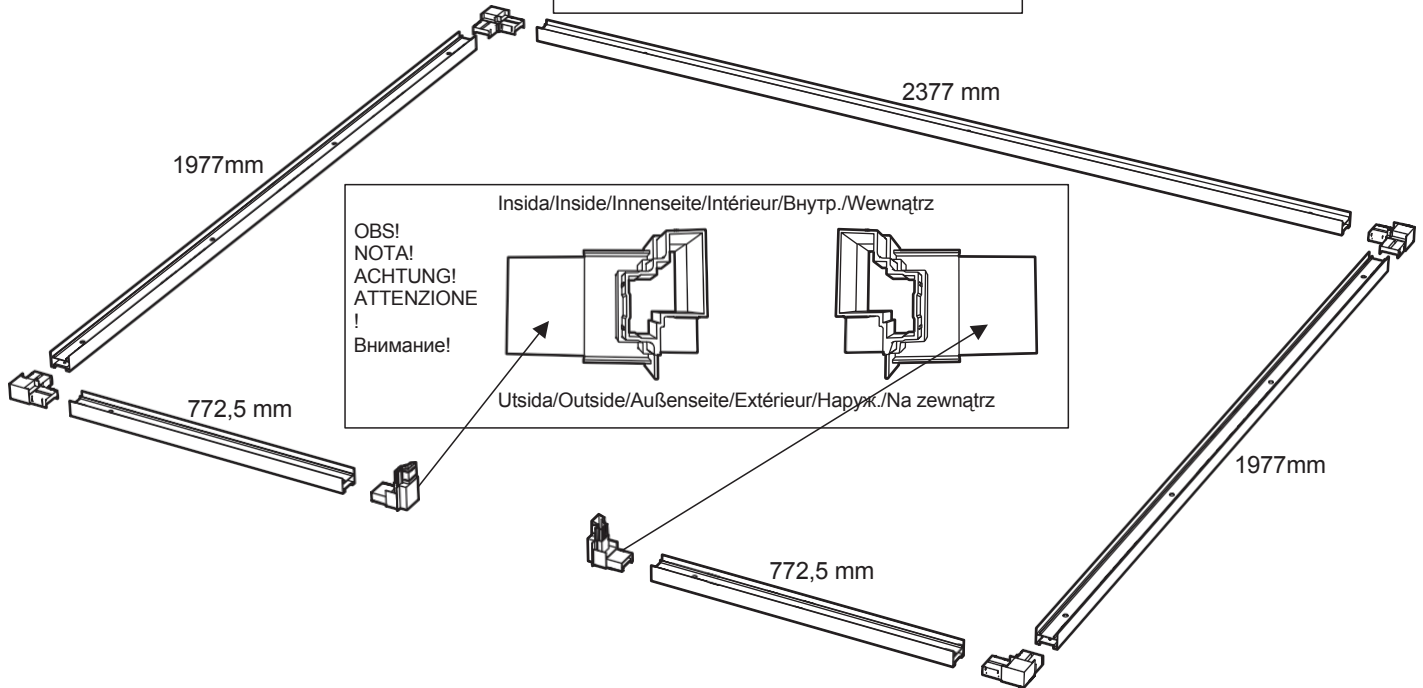
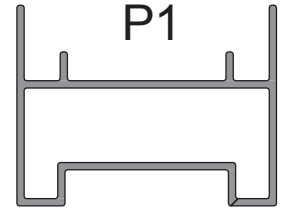

# 1 Montaggio del telaio a pavimento

Glasdörr  
Porta in  
vetro  
Glastür  
Porte vitrée

# 1000

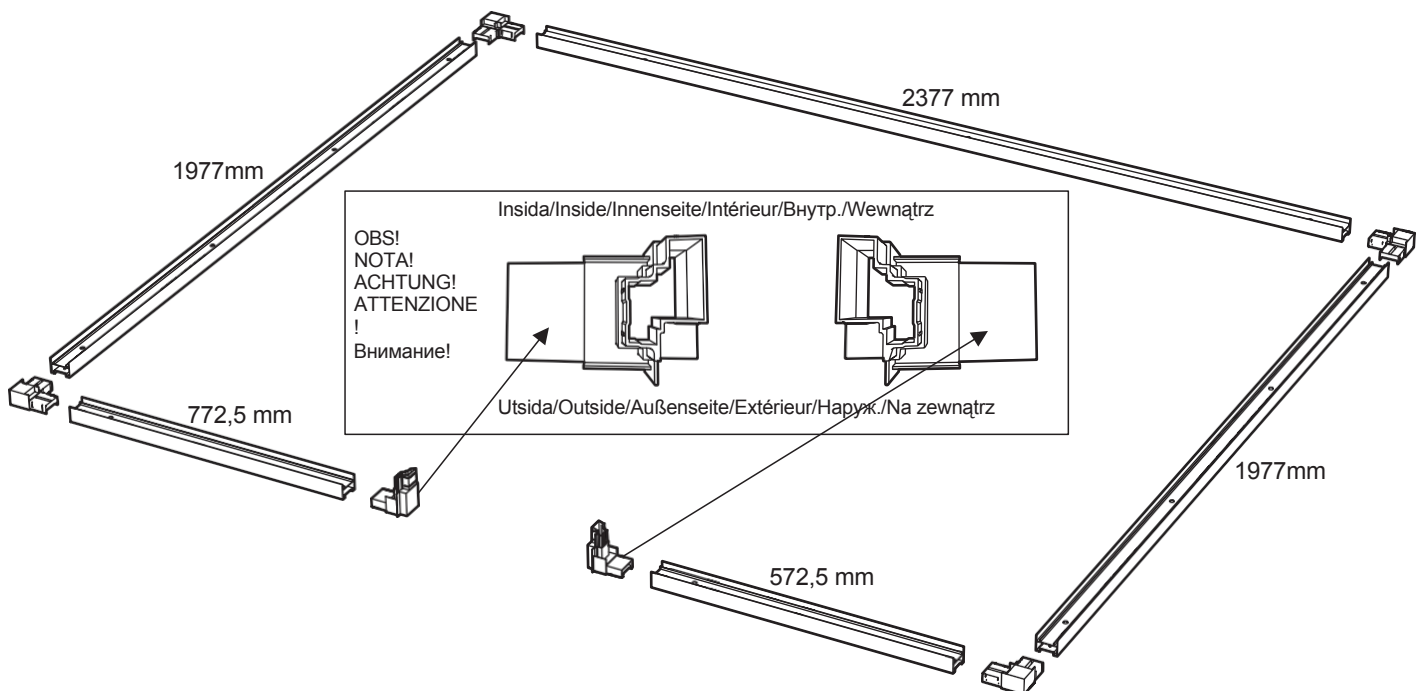
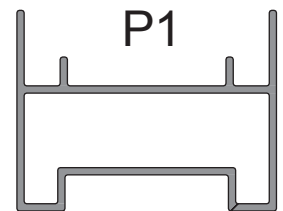

Applicare un filo di silicone sui giunti d'angolo come mostrato.

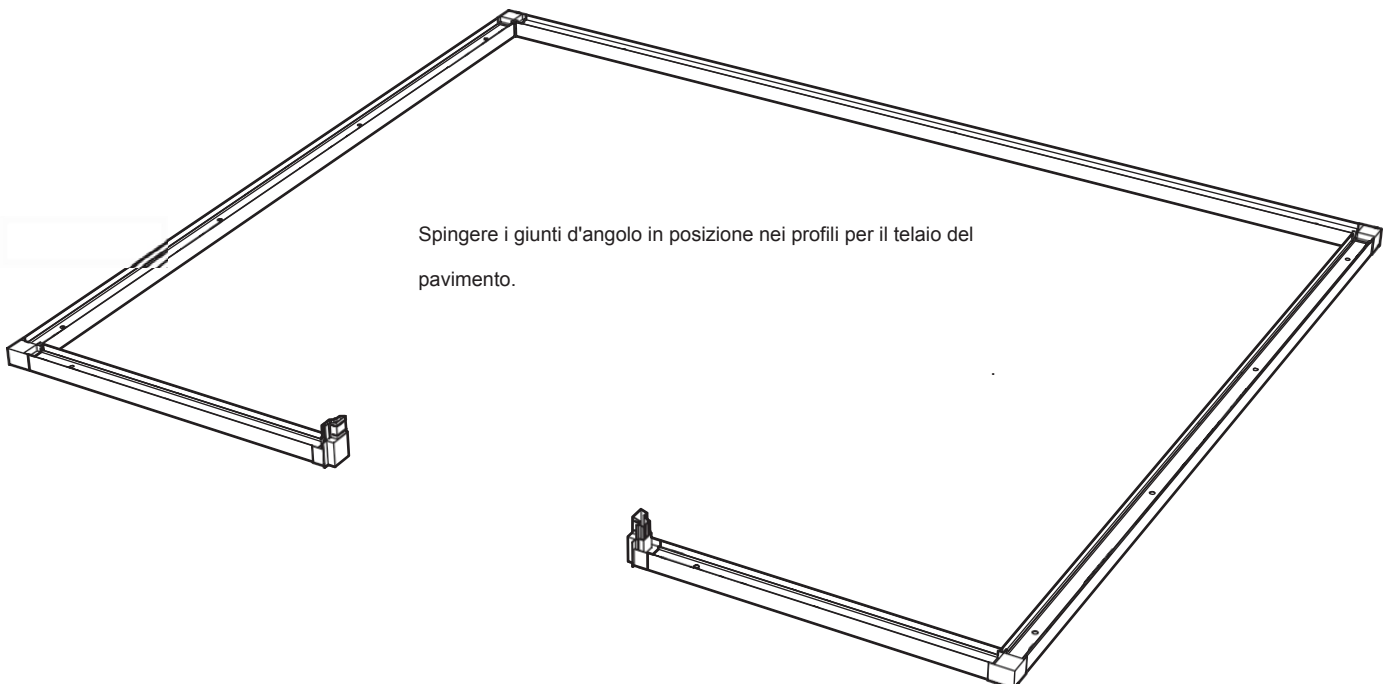
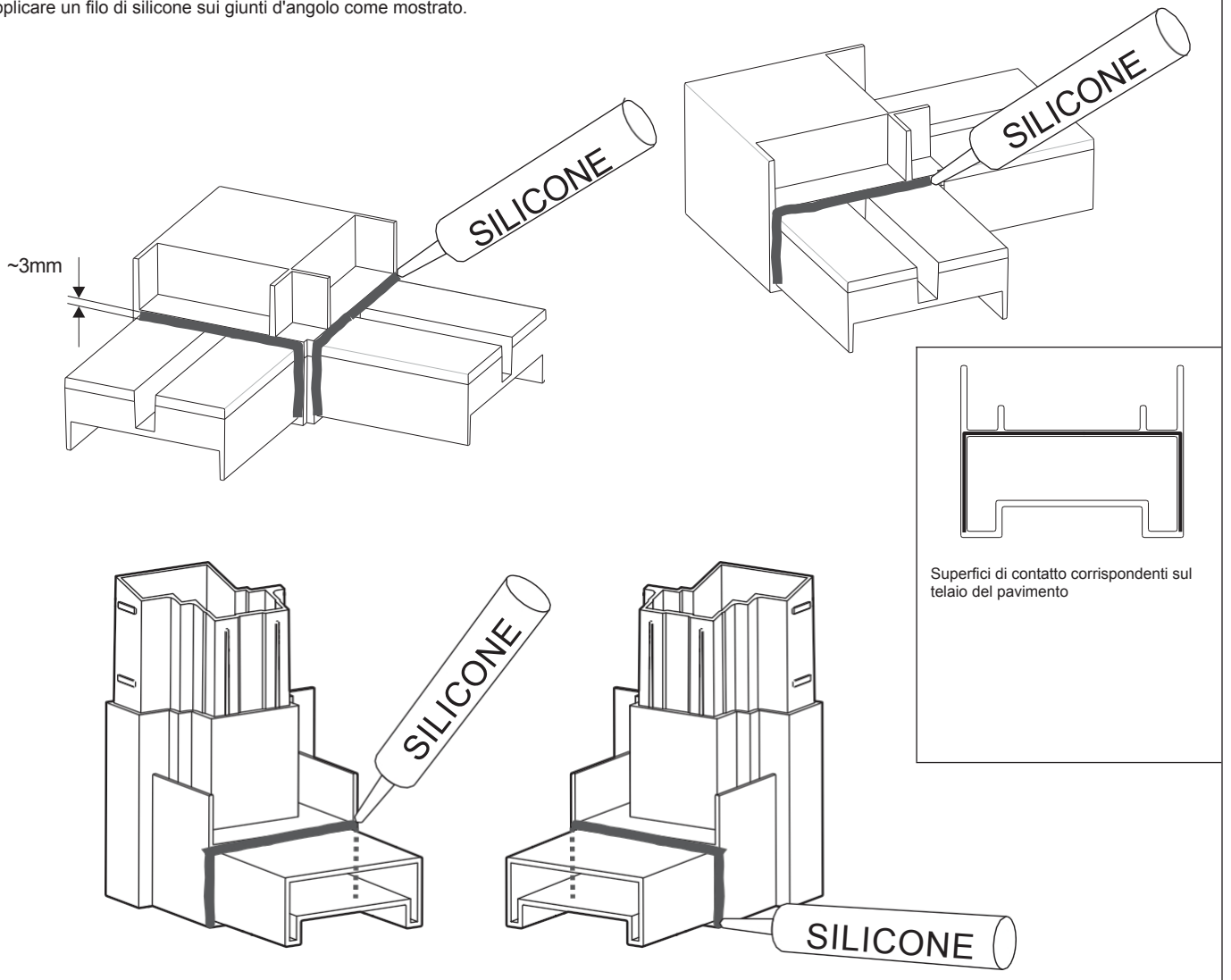

# 3

Capovolgere il telaio del pavimento. Battere con cautela i giunti d'angolo nei profili del telaio del pavimento per assicurarsi che si inseriscano completamente. Fissare i giunti angolari con le viti e montare i piedini regolabili. Avvitare i piedini regolabili fino all'arresto.

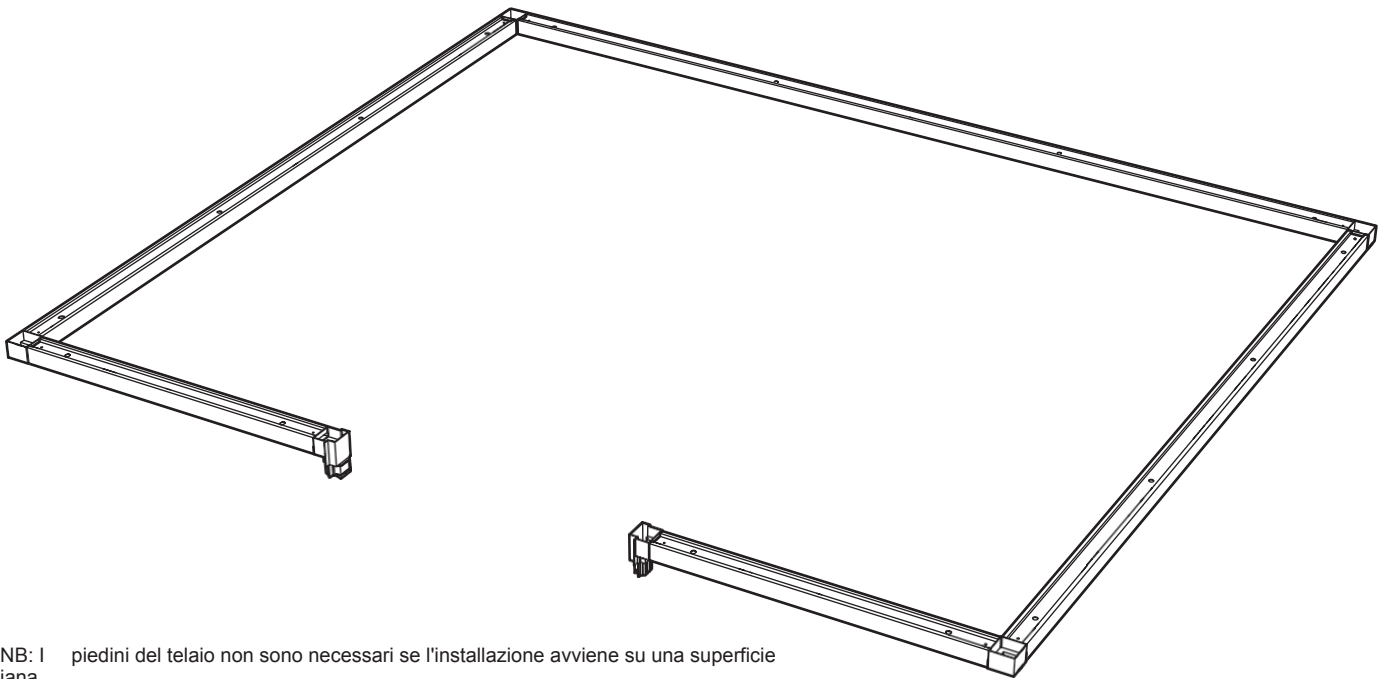

NB: I piedini del telaio non sono necessari se l'installazione avviene su una superficie piana.

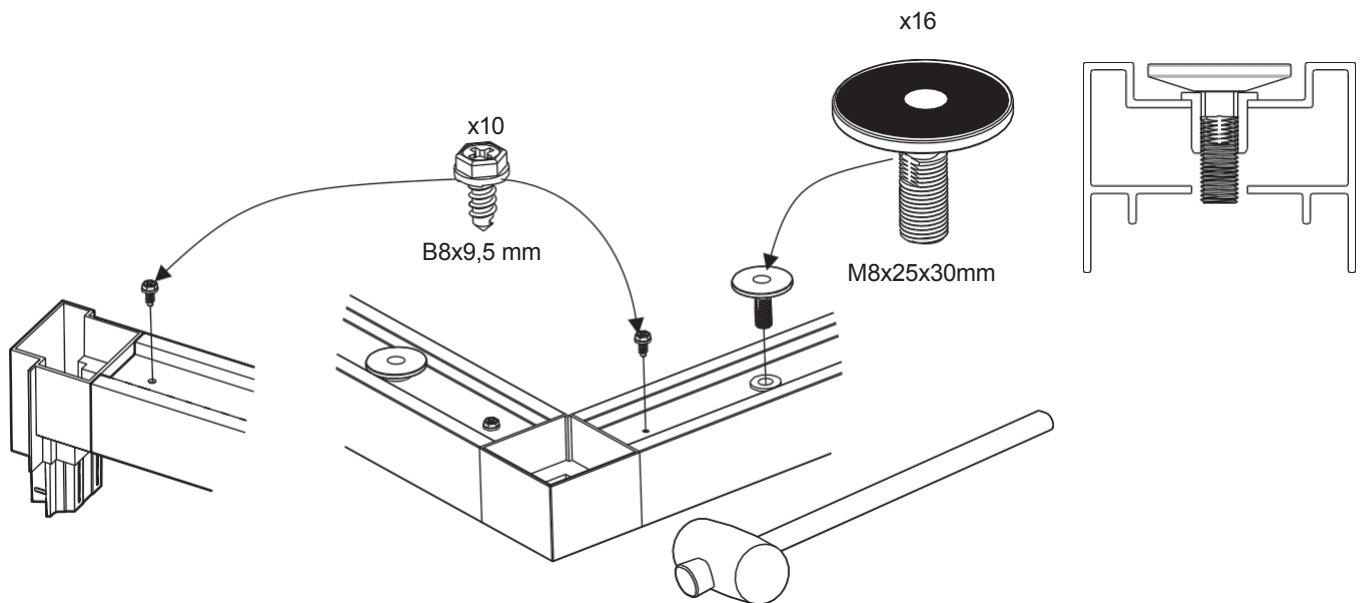

4

Girare il telaio del pavimento in modo che sia di nuovo nel verso giusto. Eliminare i residui di silicone intorno alle giunzioni angolari.

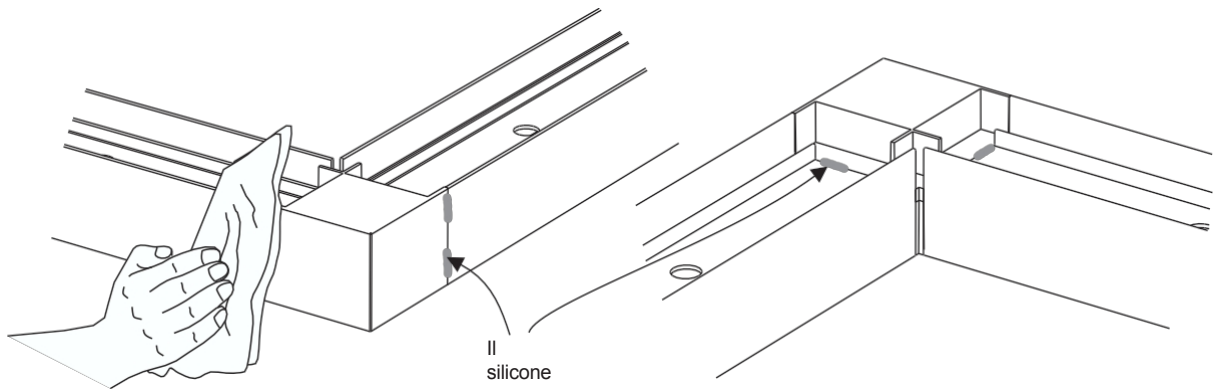
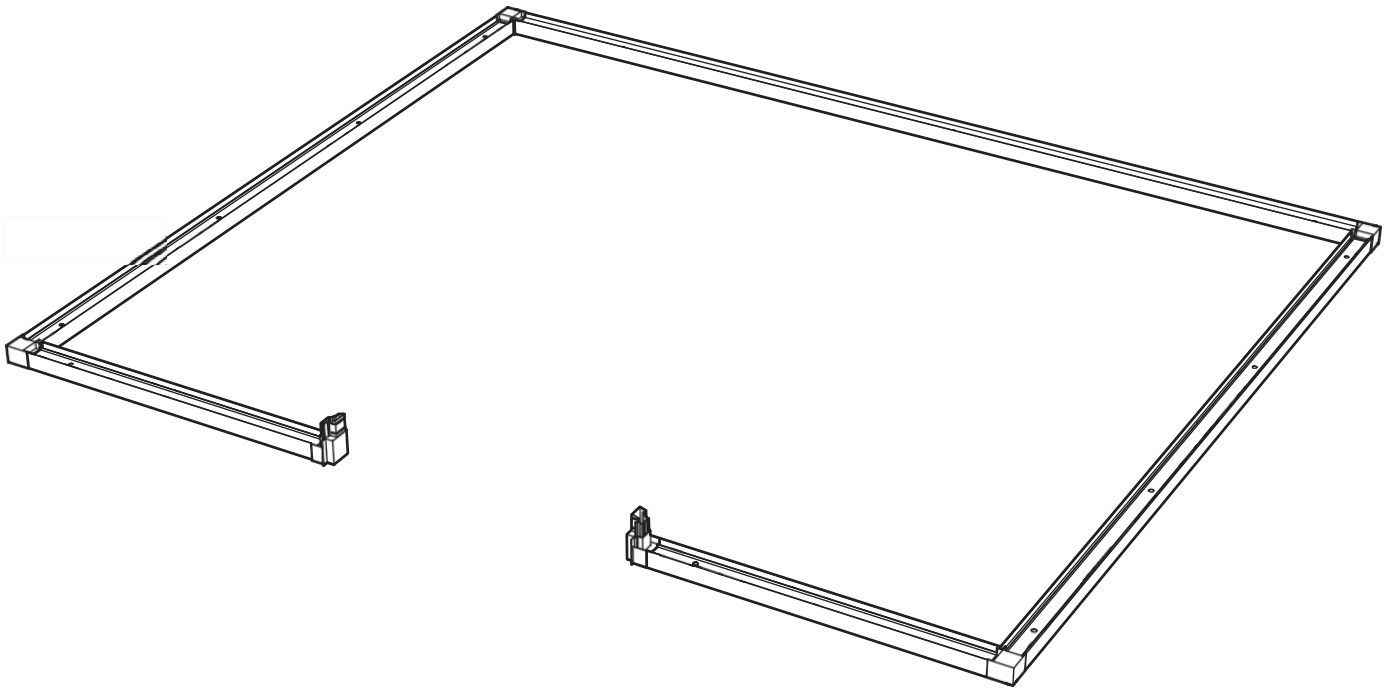

5

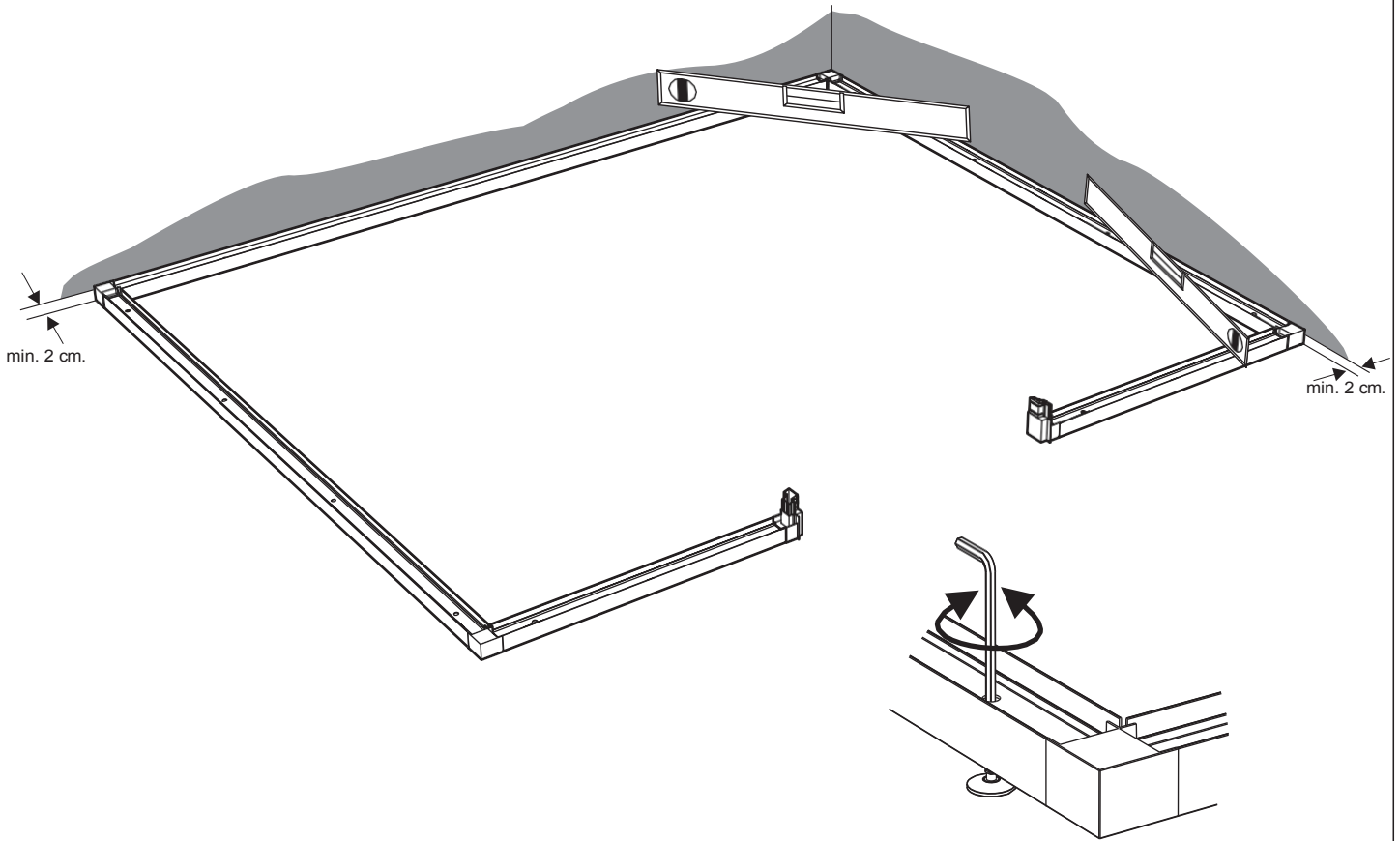

Spostate il telaio del pavimento nella posizione esatta in cui verrà montato il mobile. Utilizzare una livella a bolla d'aria per assicurarsi che il telaio sia completamente in piano sul pavimento. **IMPORTANTE!** Per un risultato finale perfetto, è essenziale che il telaio del pavimento sia assolutamente in piano. Utilizzare la chiave esagonale per regolare i piedini regolabili. È importante che la parte superiore della filettatura dei piedini regolabili sia al di sotto del livello del bordo inferiore delle pareti. (Vedere i disegni).

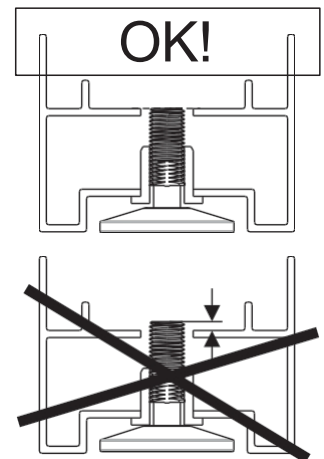

6

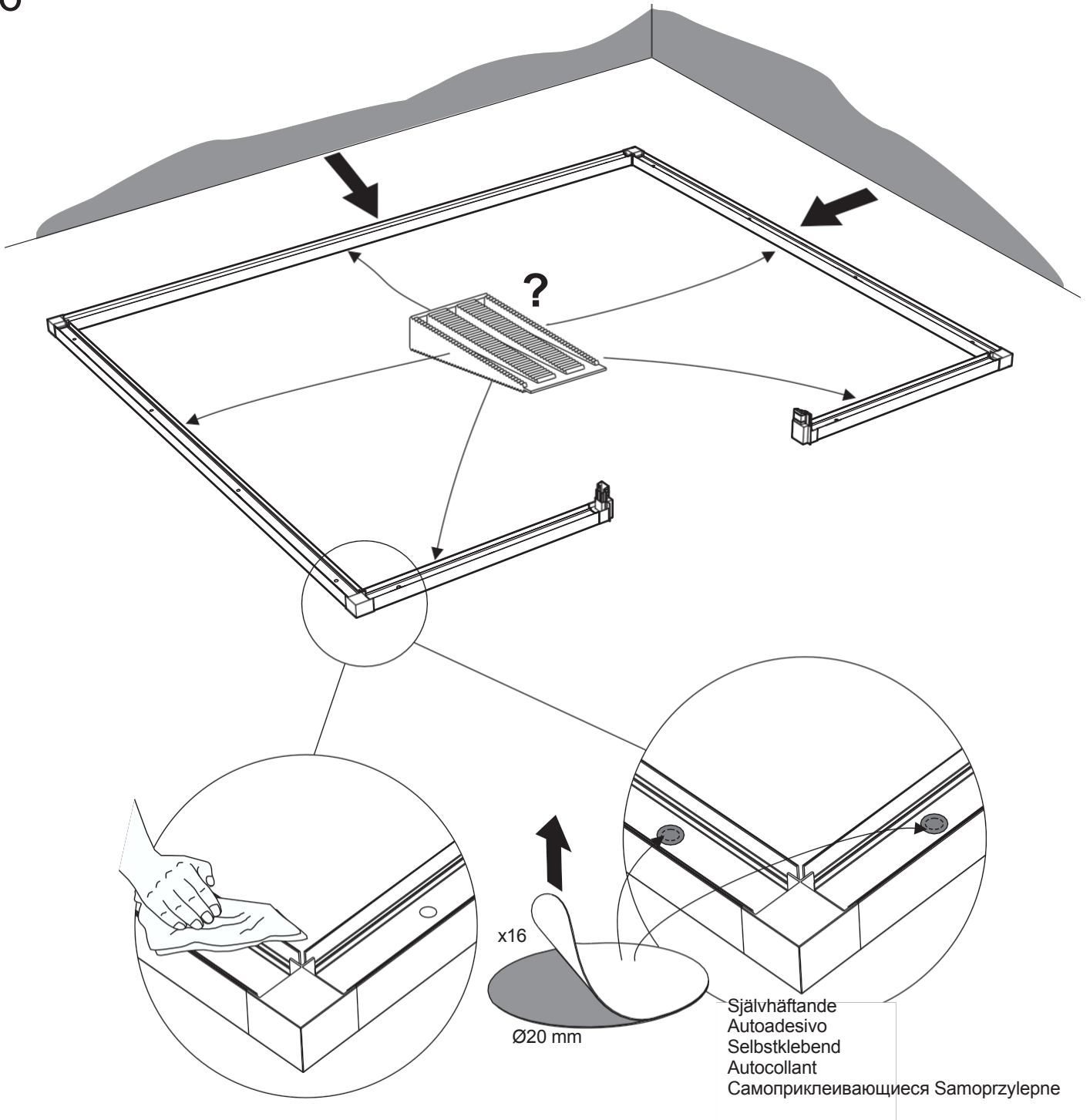

Per facilitare il montaggio, tirare il telaio del pavimento verso l'esterno della stanza se è vicino a una parete. Se in questo modo il telaio del pavimento non è più in piano, utilizzare dei cunei dove necessario per livellarlo. Pulire i fori sopra i piedini regolabili e coprirli con le piastre di tenuta circolari autoadesive.

# 7

Iniziare sempre con la vite superiore, poi con quella inferiore e infine con le due viti centrali.

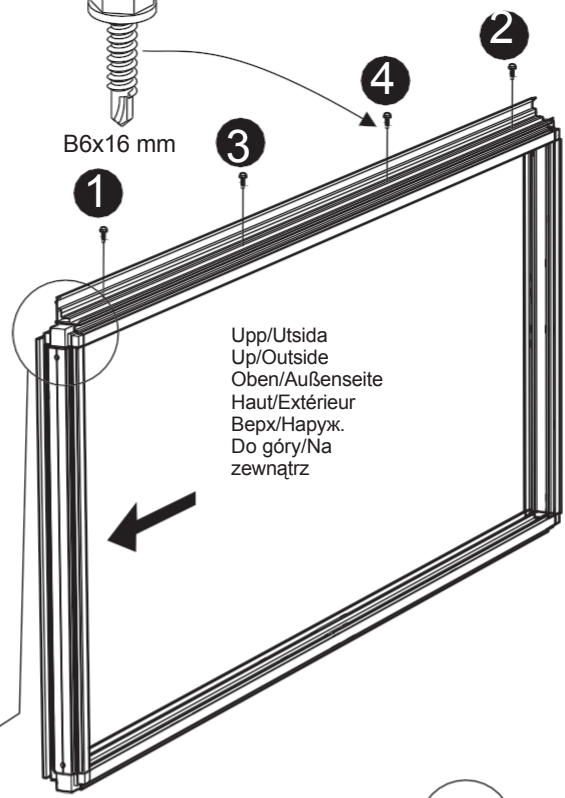
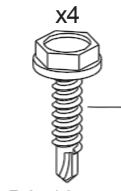

Upp/Utsida  
Up/Outside  
Oben/Außenseite  
Haut/Extérieur  
Вверх/Навух.  
Do góry/Na zewnątrz

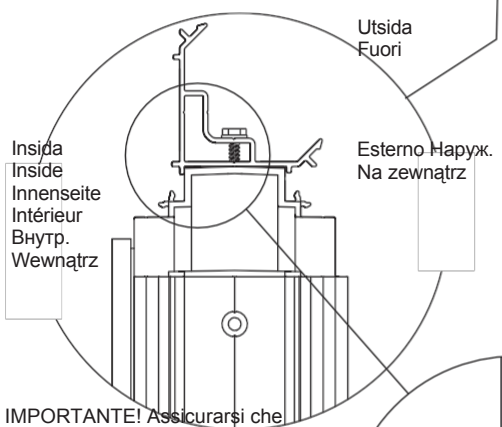
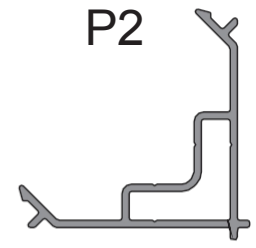
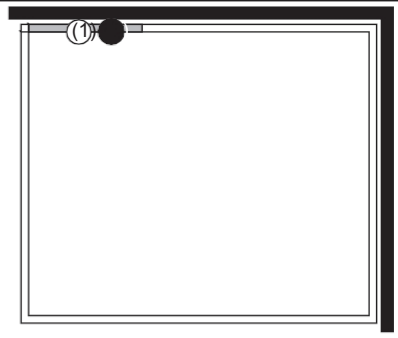

**IMPORTANT!** Assicurarsi che il profilo angolare sia perfettamente a filo con la parete. Premere il profilo contro la parete mentre lo si avvita in posizione.

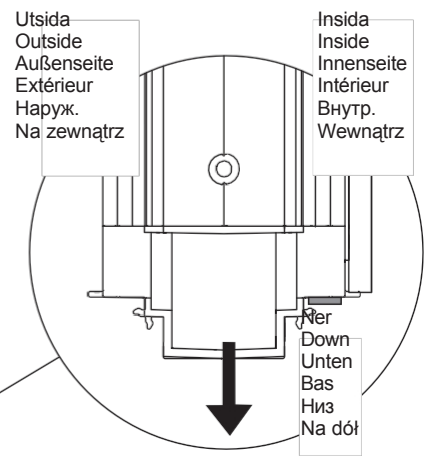
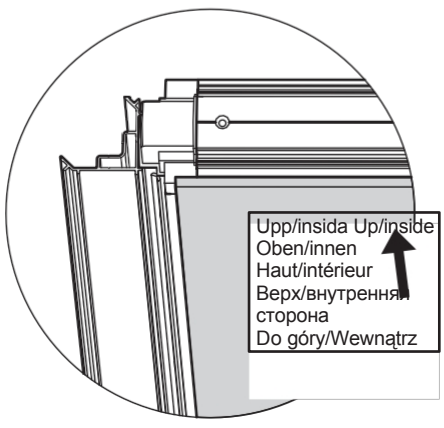
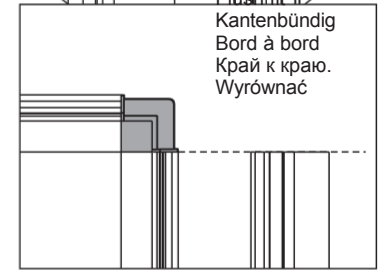
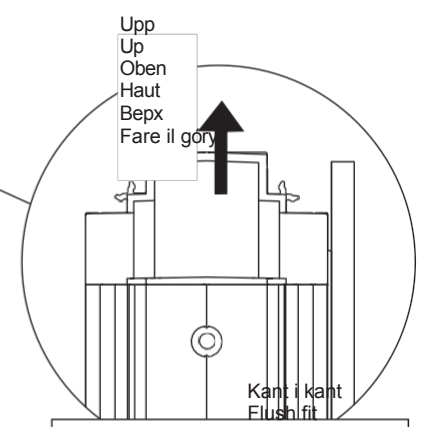
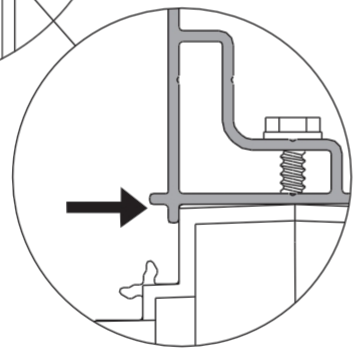

8

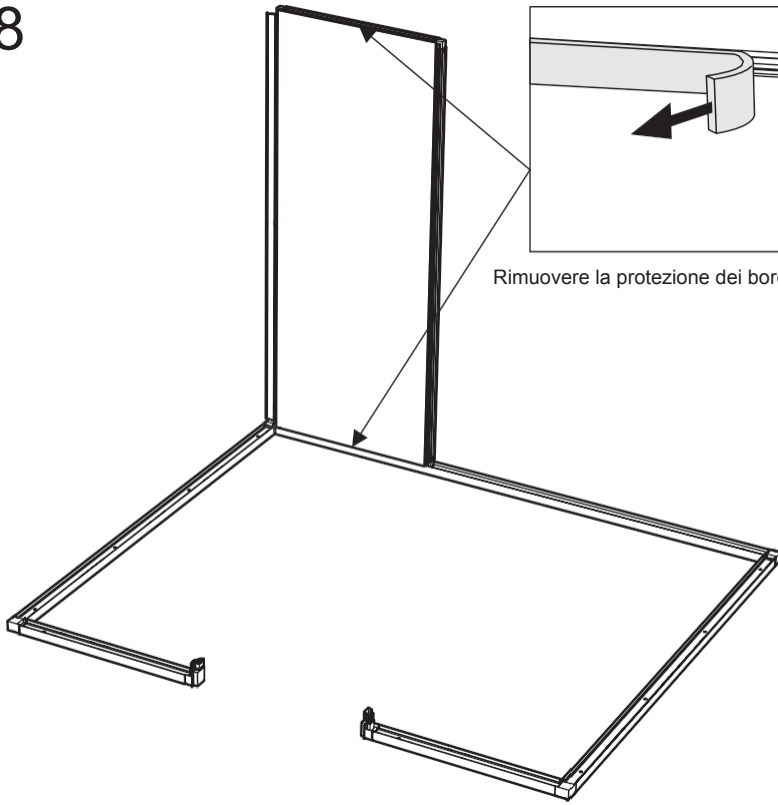

Rimuovere la protezione dei bordi quando si monta la parete

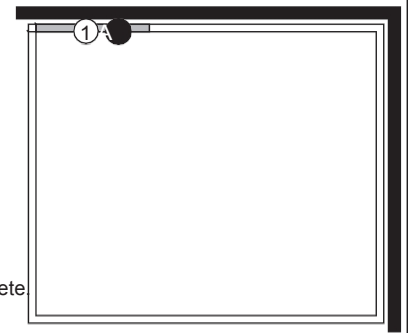

Utsida Outside  
Außenseite  
Extérieur  
Навуж.  
Na zewnątrz

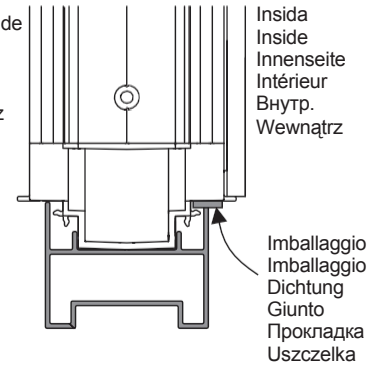

Insida Inside  
Innenseite  
Intérieur  
Внутр.  
Wewnątrz

Imballaggio  
Dichtung  
Giunto  
Прокладка  
Uszczelka

9

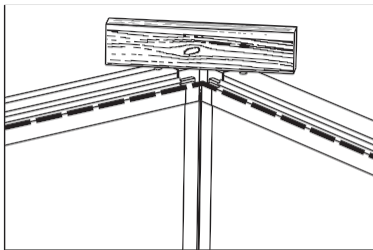

IMPORTANTE! Le pareti devono essere perfettamente in piano nel punto di incontro con gli angoli.

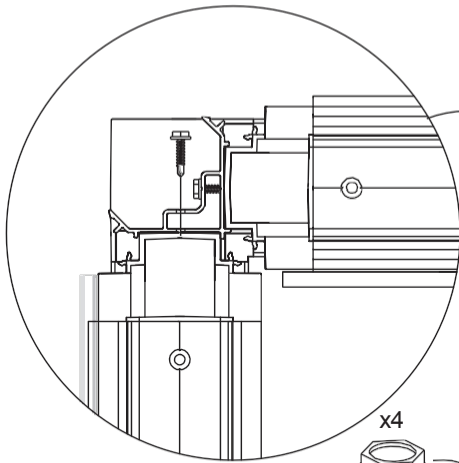
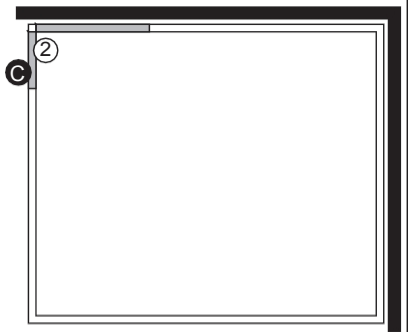

x4



B6x16 mm

Spingere le pareti insieme mentre vengono avvitate.

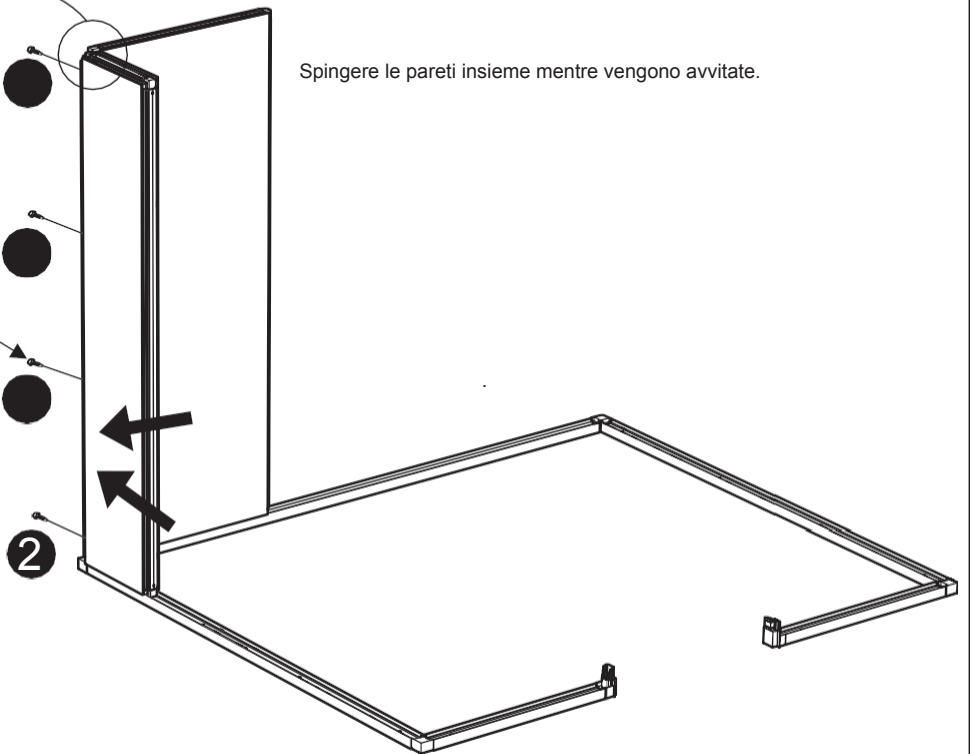

Utsida  
Outside  
Außenseite  
Extérieur  
Навуж.  
Na zewnątrz

Insida  
Inside  
Innenseite  
Intérieur  
Внутр.  
Wewnątrz

Imballaggio  
Dichtung  
Giunto  
Прокладка  
Uszczelka

10

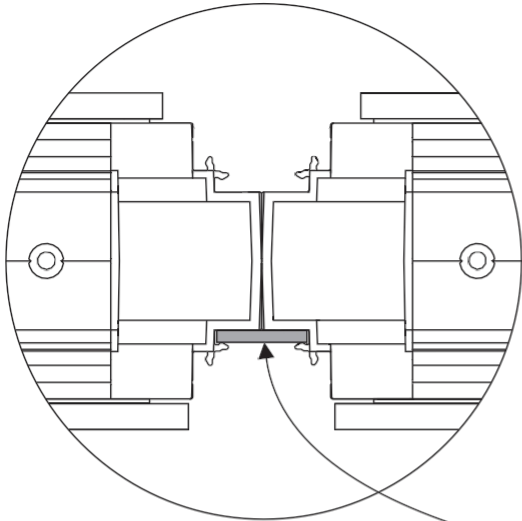
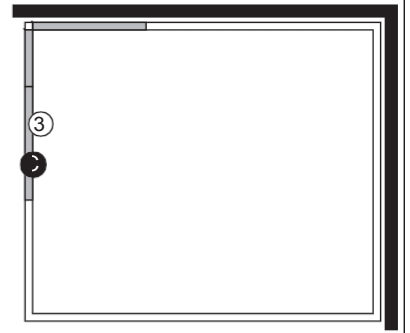

Piastra di  
bloccaggio  
Sicherungsscheibe  
Rondelle de blocage  
Направление Плитка  
blokujača  
x1



33x21x3mm

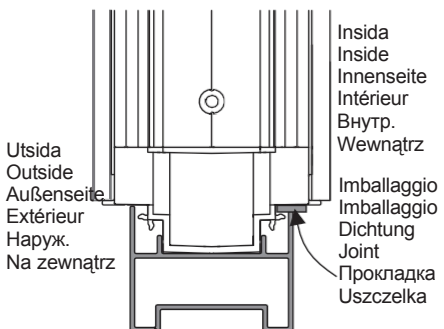
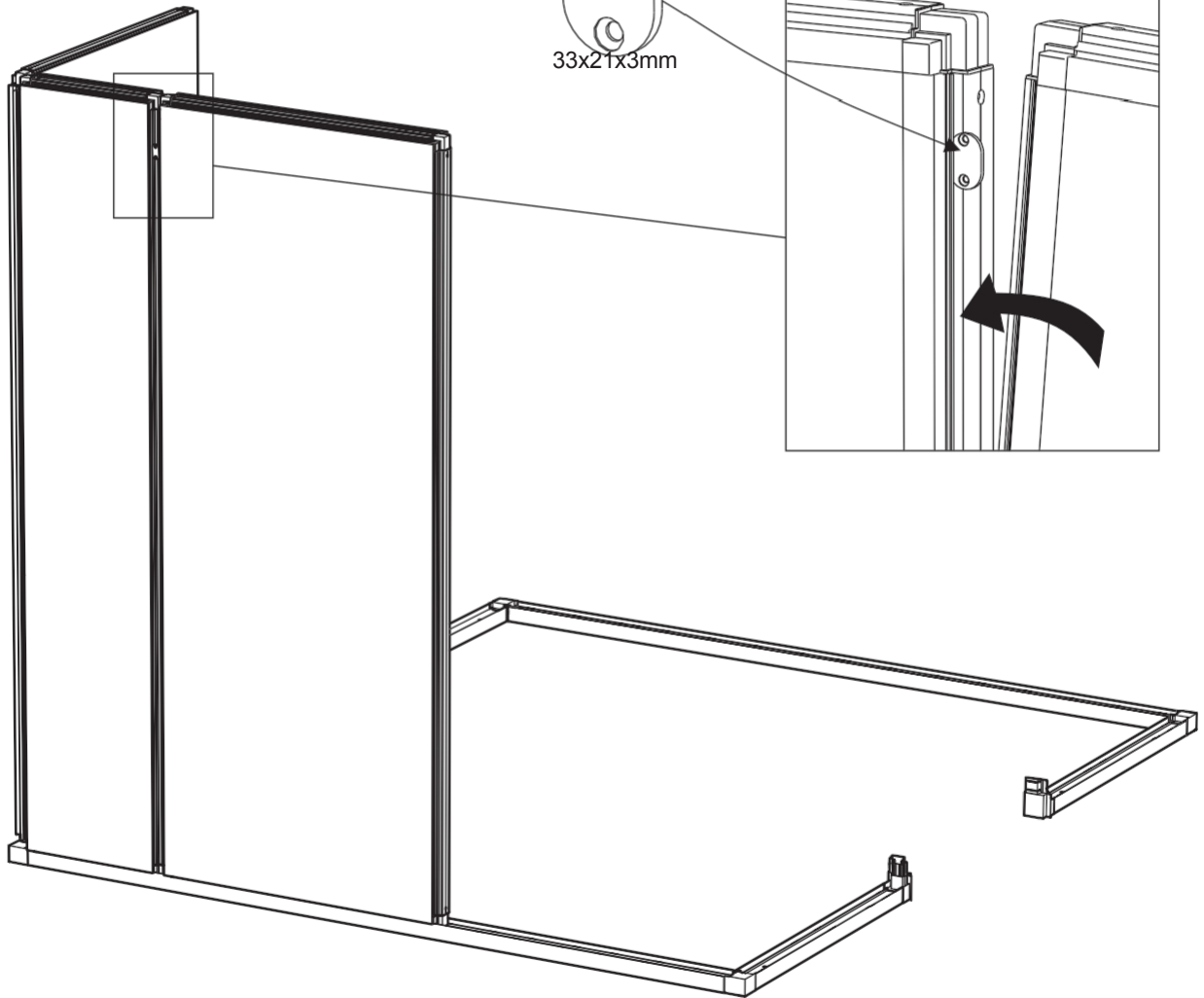
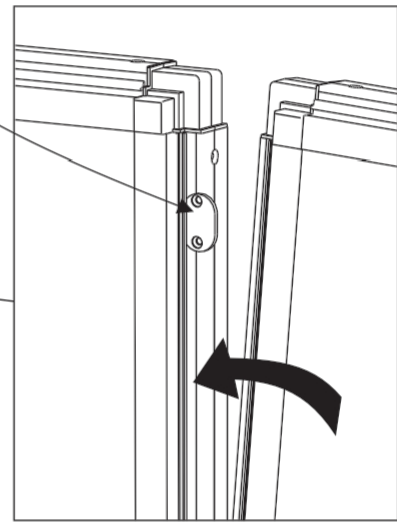

Utsida  
Outside  
Außenseite  
Extérieur  
Наруж.  
Na zewnątrz

Insida  
Inside  
Innenseite  
Intérieur  
Внутр.  
Wewnątrz  
Imballaggio  
Imballaggio  
Dichtung  
Joint  
Прокладка  
Uszczelka

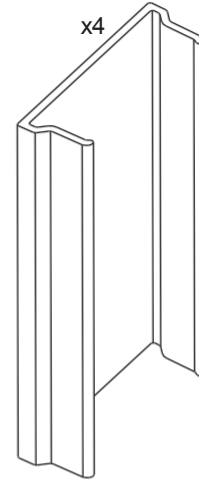
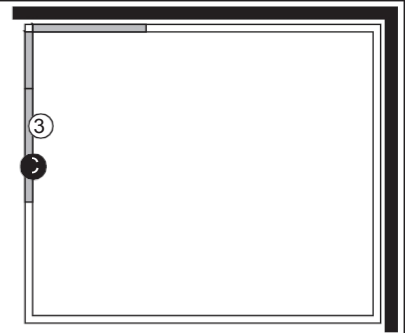
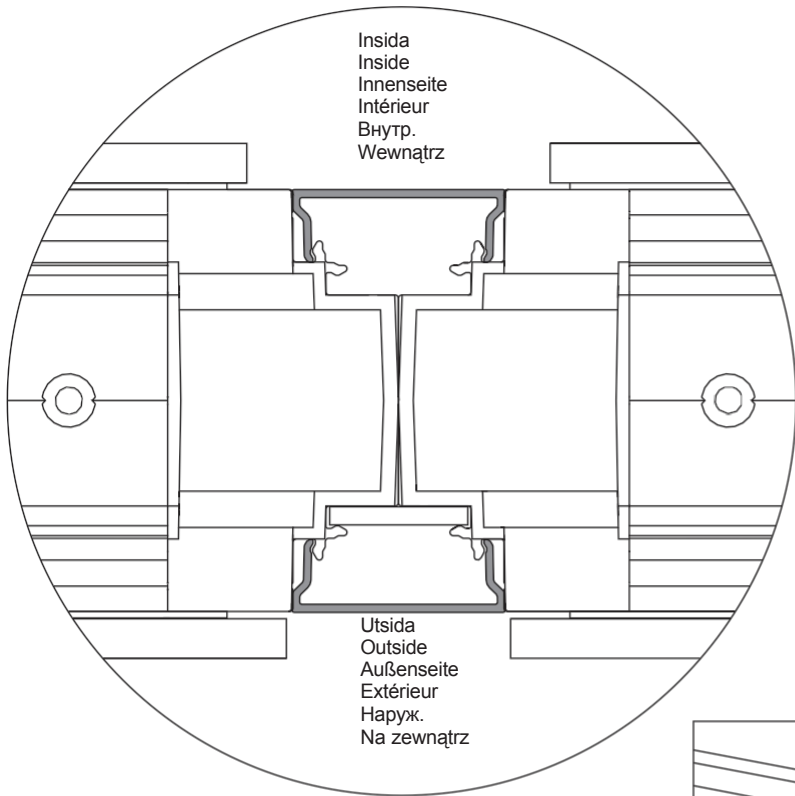

70 mm

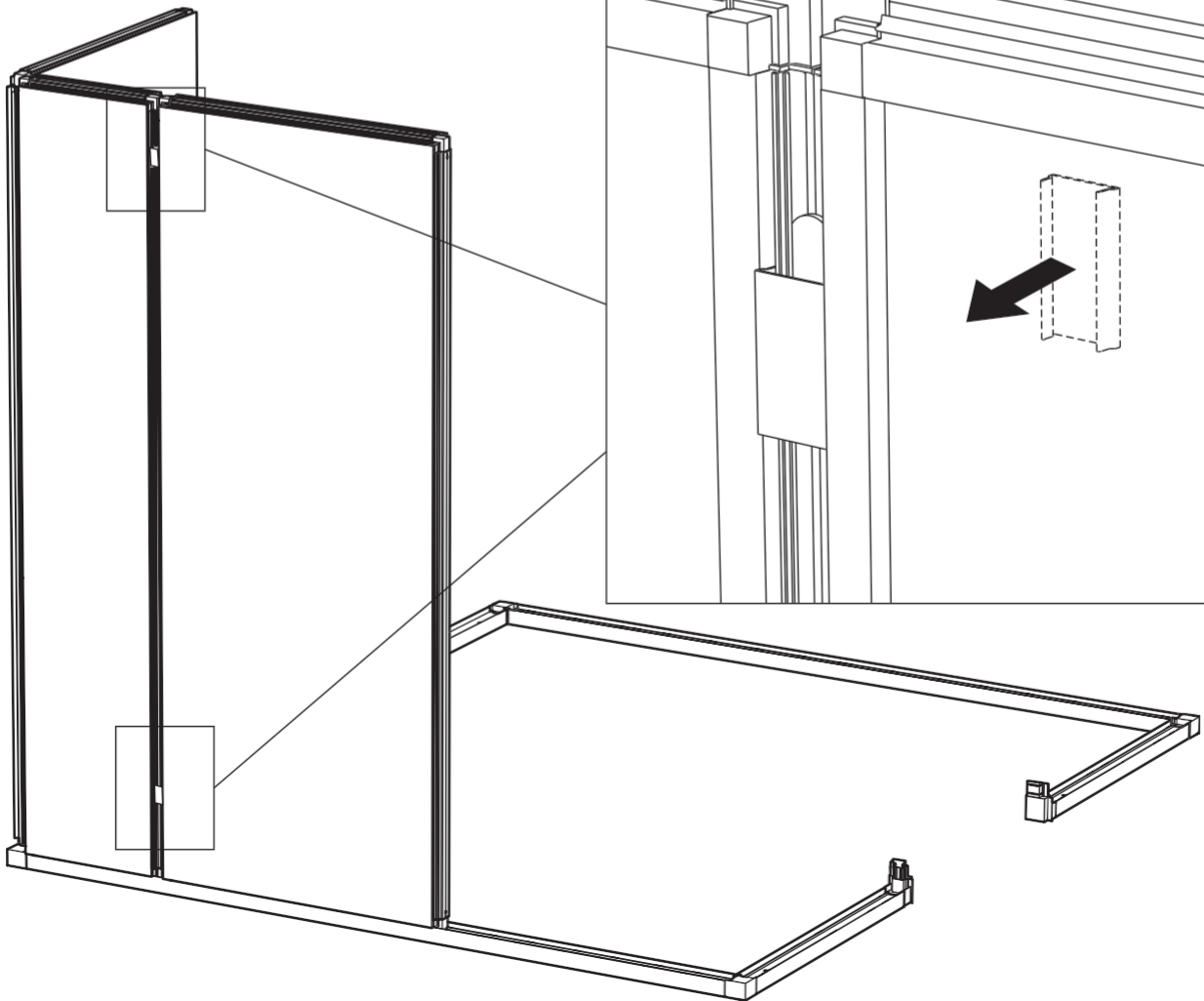
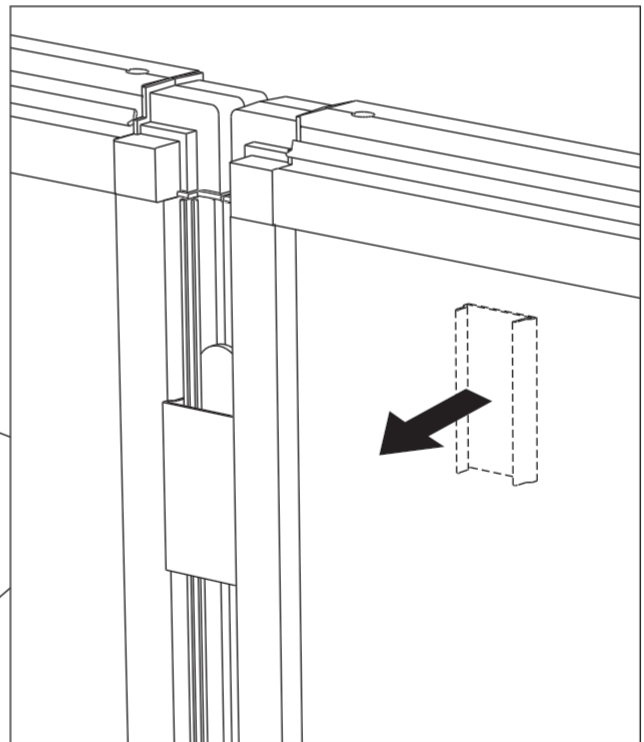

# 12

Sektion för ånga  
sezione vapore  
Sezione Dampf.  
la sezione di vapore  
пара разделе  
Seksja  
parowa

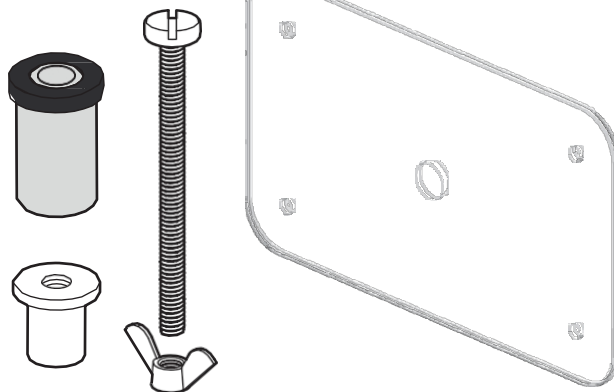
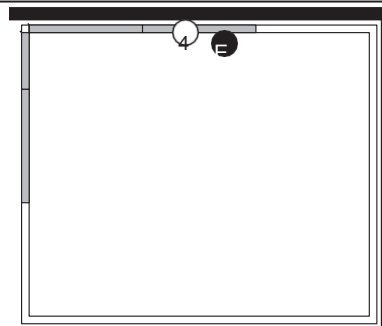
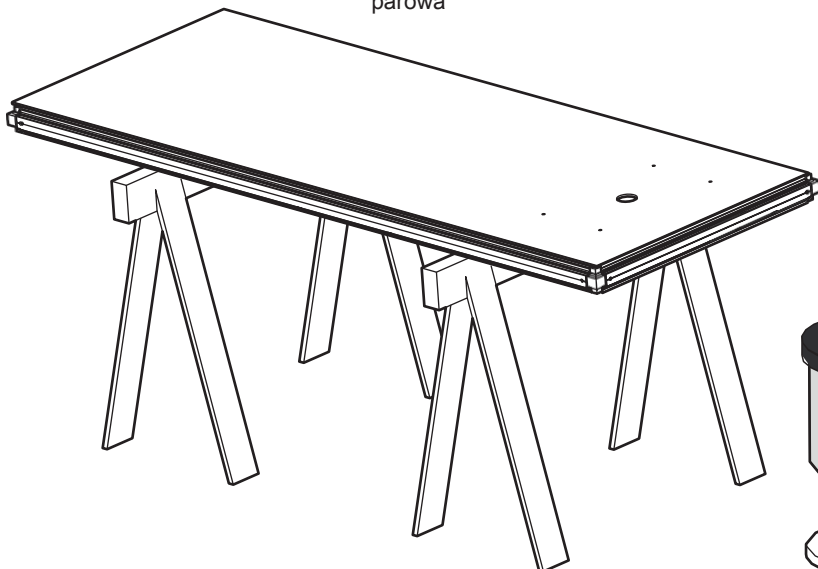

### 1

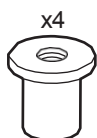

Grönt glas Vetro  
verde Grünes  
Glas Verre vert  
Зеленое стекло  
Zielona szyba

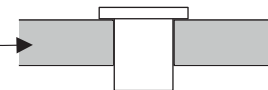

### 2

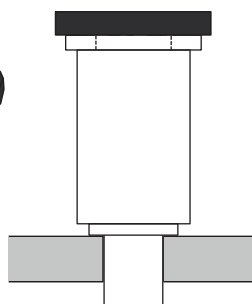

### 3

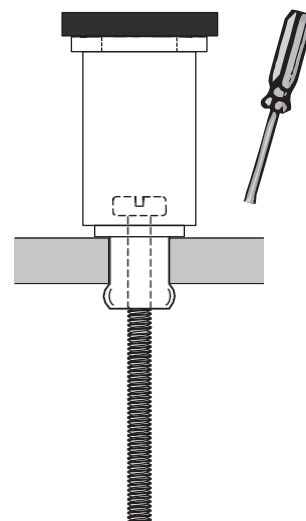

### 4

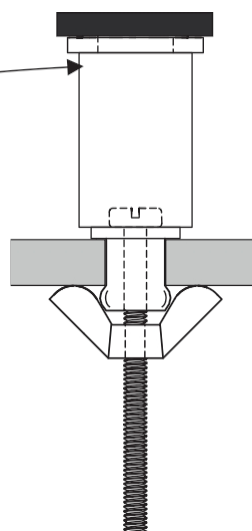
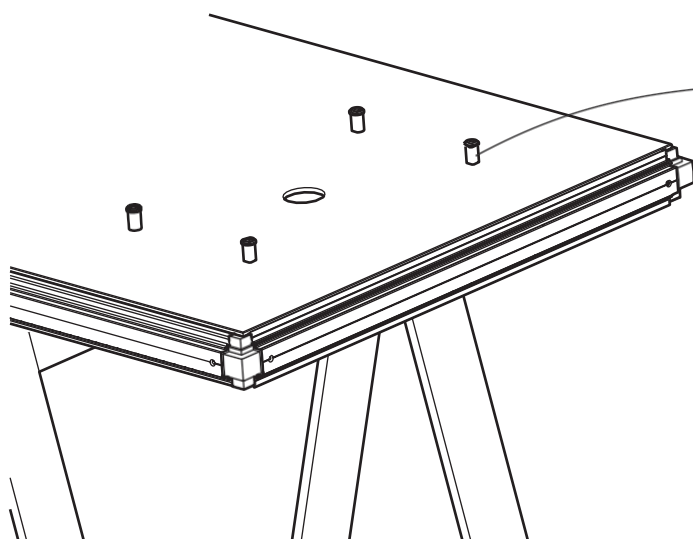

Säkra med vingmuttrar  
Fissaggio con dadi ad alette

13

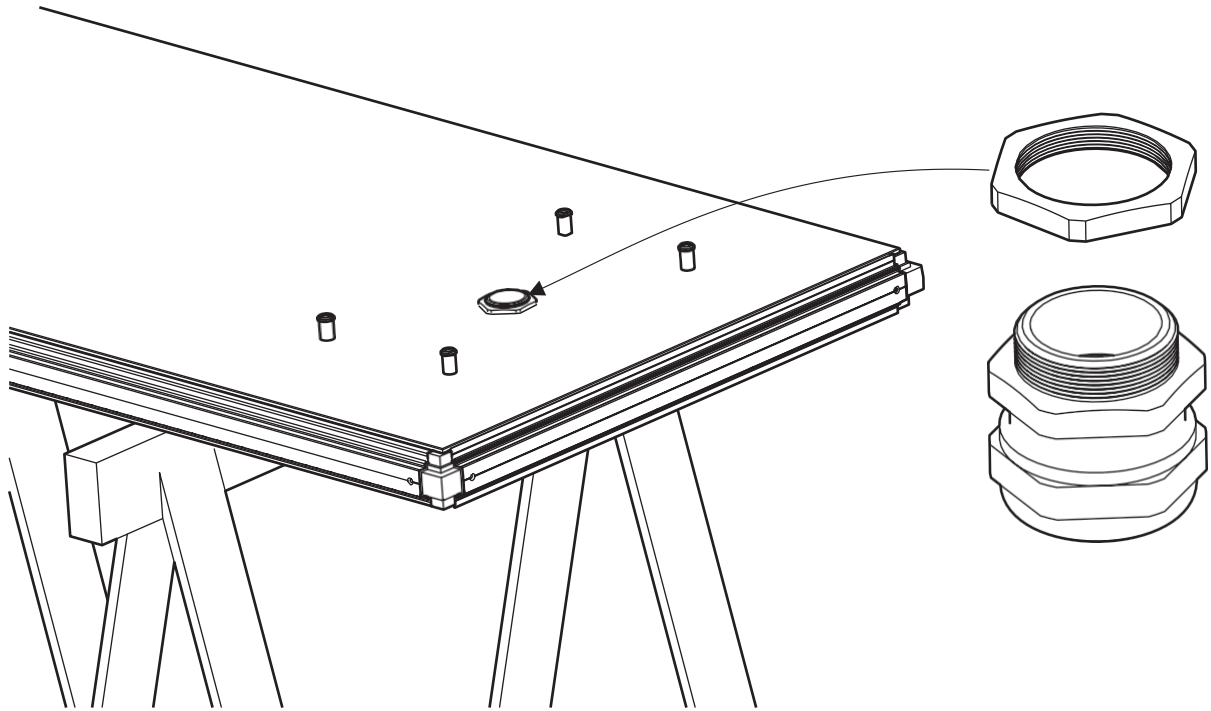
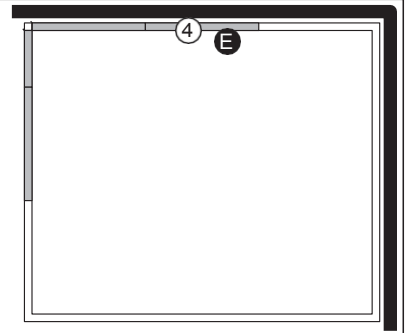

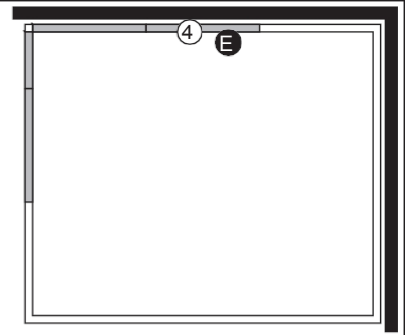

Piastra di bloccaggio  
Sicherungsscheibe  
Rondelle de blocage  
Направление Плитка  
blokiująca  
x1

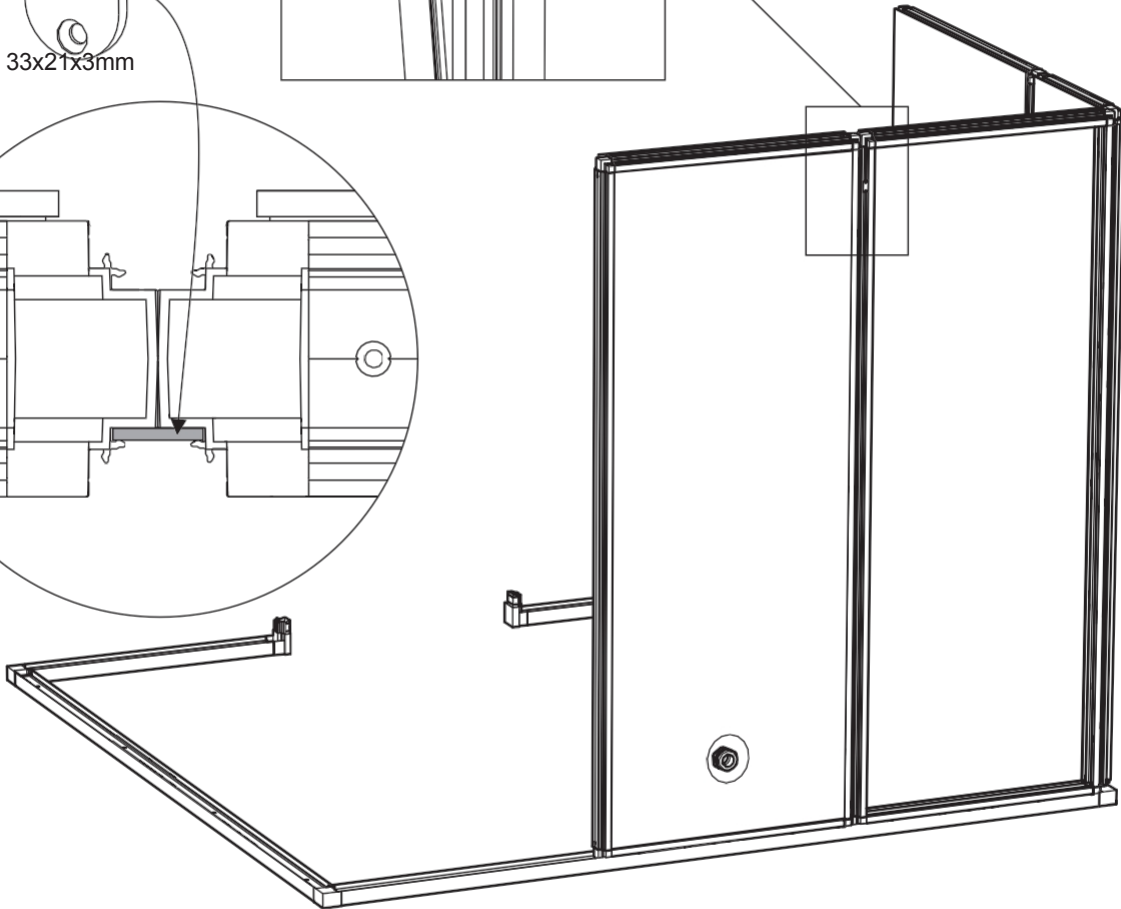
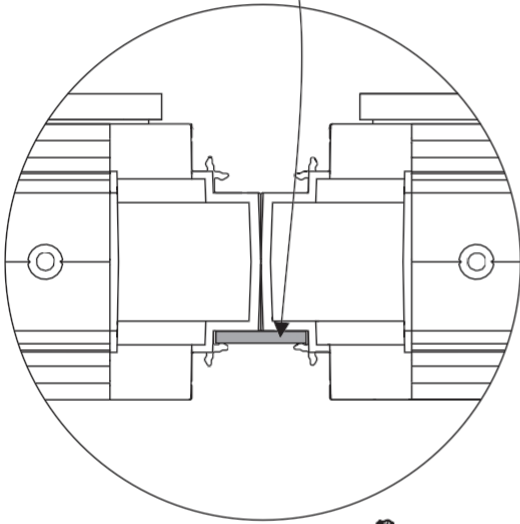
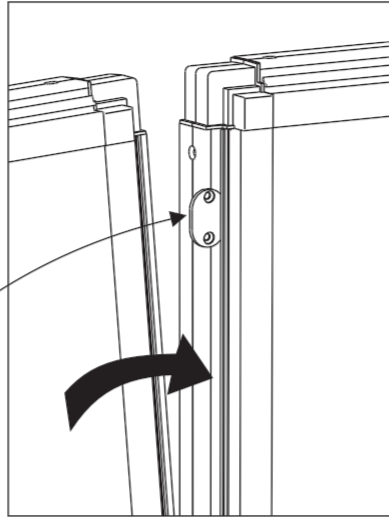
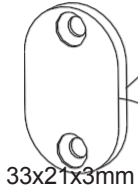

Utsida  
Outside  
Außenseite  
Extérieur  
Наруж.  
Na zewnątrz

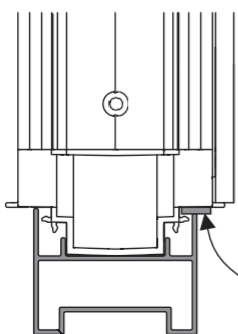

Insida  
Inside  
Innenseite  
Intérieur  
Внутр.  
Wewnątrz

Imballaggio  
Imballaggio  
Dichtung Joint  
Прокладка  
Uszczelka



16

P2

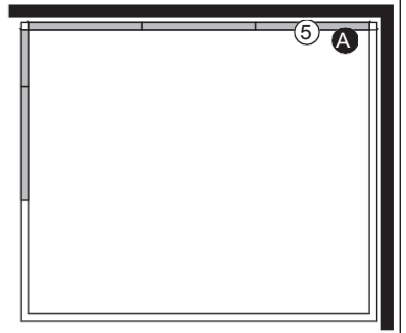
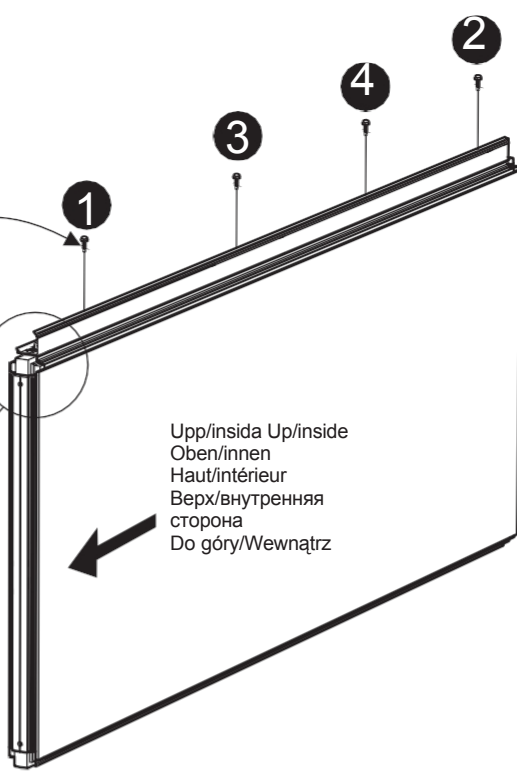
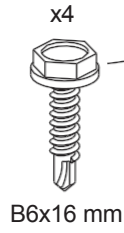
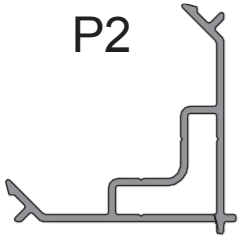

Upp/insida Up/inside  
Oben/innen  
Haut/intérieur  
Верх/внутренняя  
сторона  
Do góry/Wewnątrz

Utsida  
Outside  
Außenseite  
Extérieur  
Наруж.  
Na zewnątrz

Insida  
Inside  
Innenseite  
Intérieur  
Внутр.  
Wewnątrz

Upp  
Up  
Oben  
Haut  
Верх  
Fai da te

OBS!  
NOTA!  
ACHTUNG!  
ATTENZIONE  
!  
Внимание!

Kant i kant Flush  
fit Kantenbündig  
Bord à bord  
Край к краю.  
Wyrównać

Upp/insida Up/inside  
Oben/innen  
Haut/intérieur  
Верх/внутренняя  
сторона  
Do góry/Wewnątrz

Insida  
Inside  
Innenseite  
Intérieur  
Внутр.  
Wewnątrz

Utsida Outside  
Außenseite  
Extérieur  
Наруж.  
Na zewnątrz

Neer  
Down  
Unten  
Bas  
Низ  
Na dół

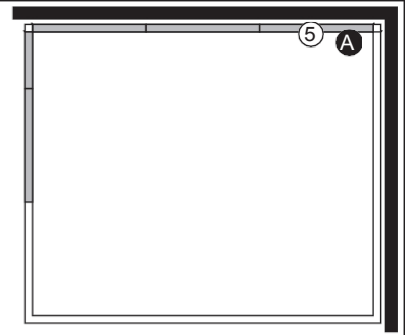

Piastra di bloccaggio  
Sicherungsscheibe  
Rondelle de blocage  
Направление Плитка  
blokujaća  
x1

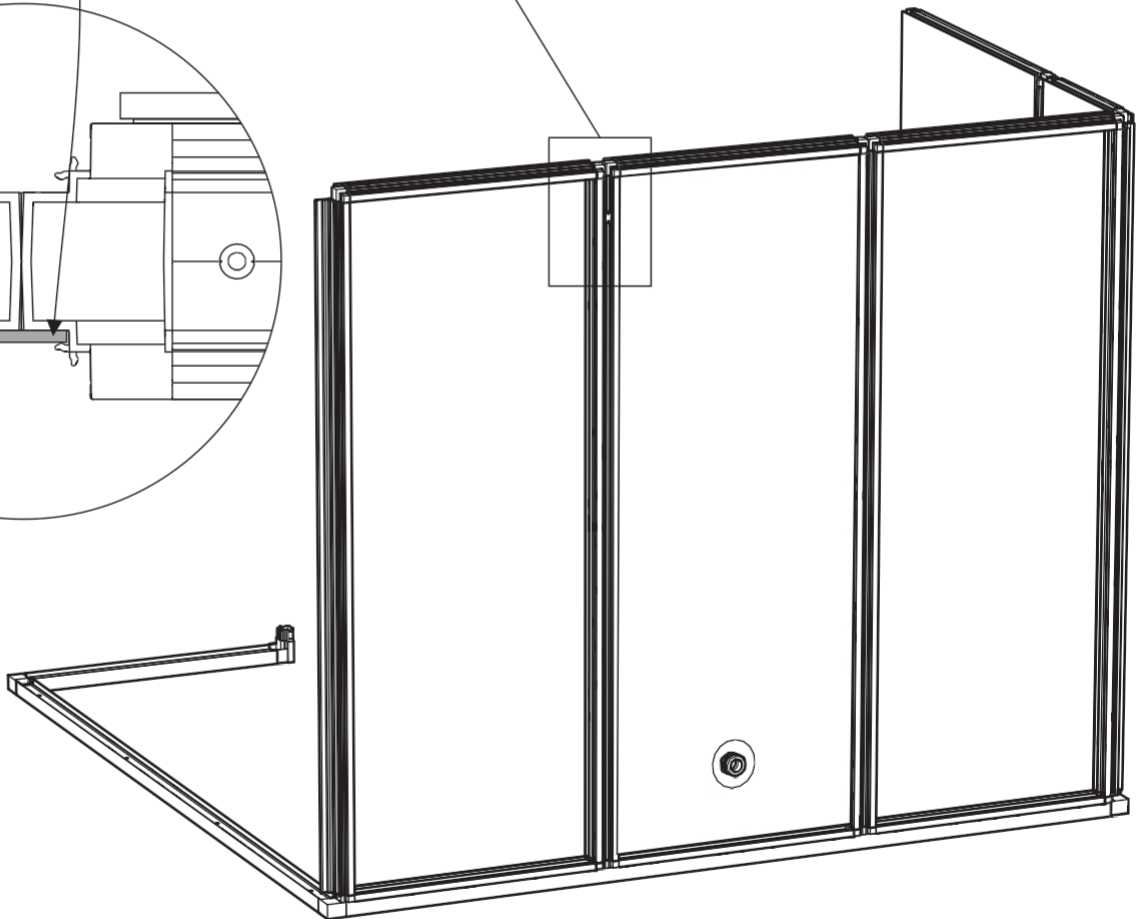
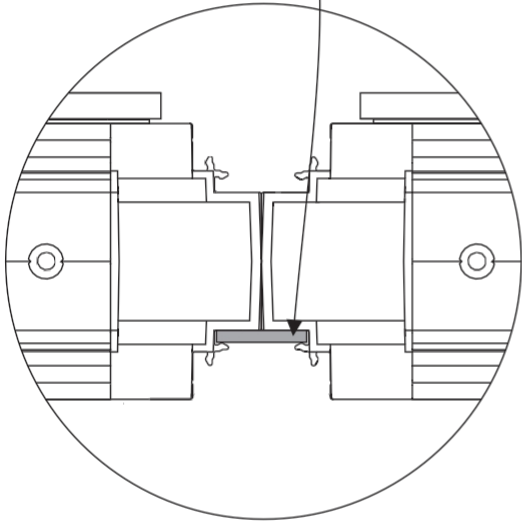
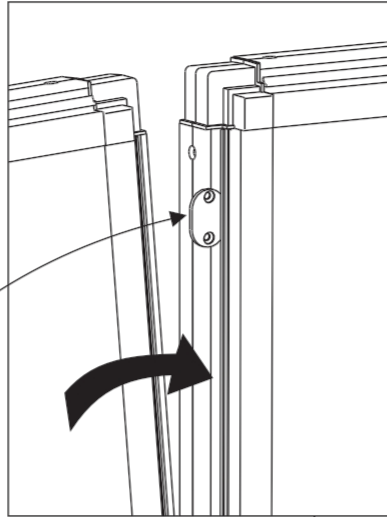

Utsida  
Outside  
Außenseite  
Extérieur  
Наруж.  
Na zewnątrz

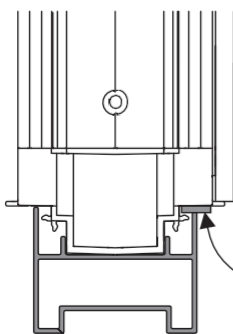

Insida  
Inside  
Innenseite  
Intérieur  
Внутр.  
Wewnątrz

Imballaggio  
Imballaggio  
Dichtung  
Joint  
Прокладка  
Uszczelka

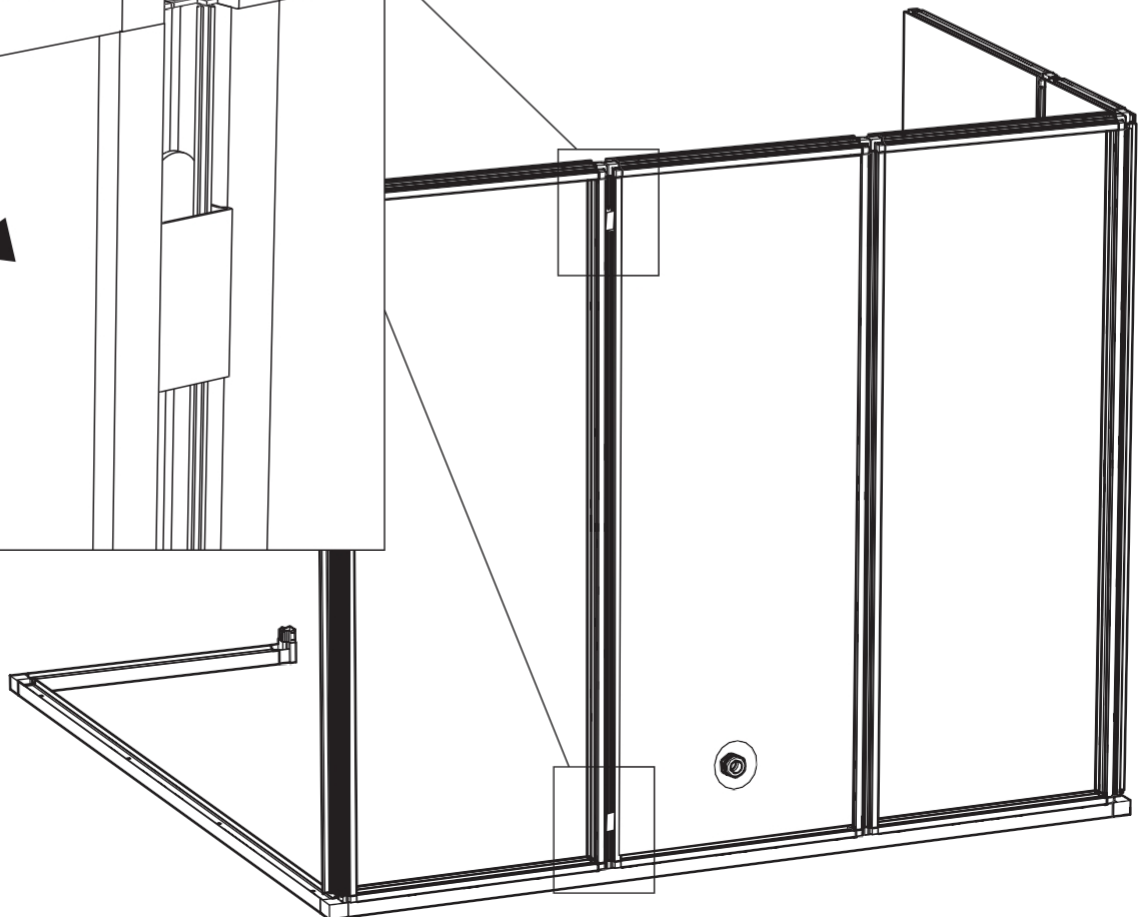
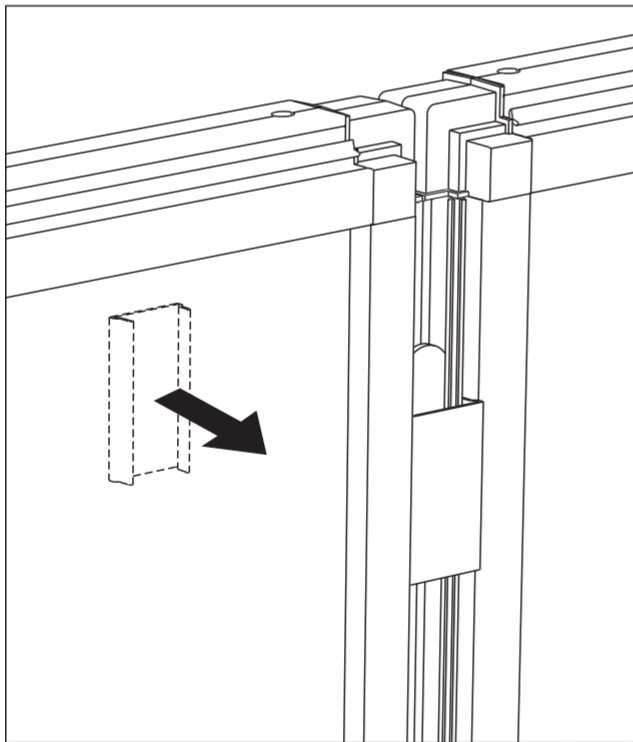
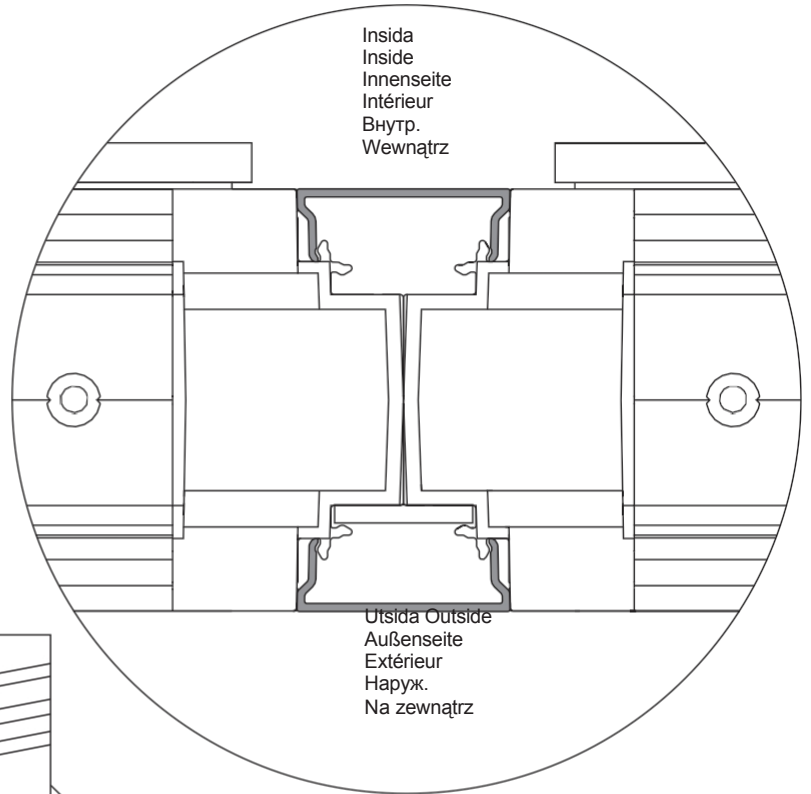
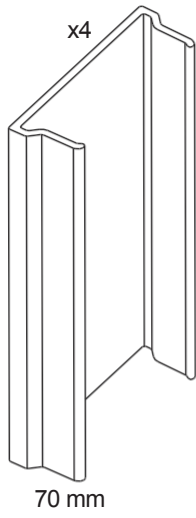
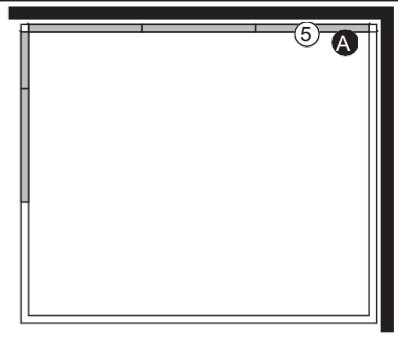

19

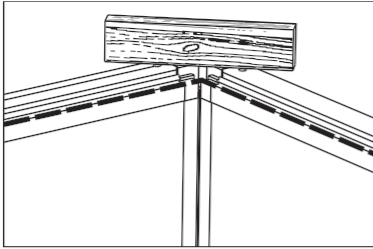

OBS! È strano che i vāggarna si trovino in mezzo alla strada.  
**IMPORTANTE!** Le pareti devono essere perfettamente piane nel punto di incontro con gli angoli.  
**ACHTUNG!** Le pareti devono essere perfettamente livellate in corrispondenza degli angoli.  
**ATTENZIONE!** È importante che le cloisons siano allo stesso livello negli angoli.  
**Внимание!** Важно, чтобы стенки были на одинаковой высоте в углу.  
**WAŻNE!** Ścianki w narożniku muszą być dokładnie na tym samym poziomie.

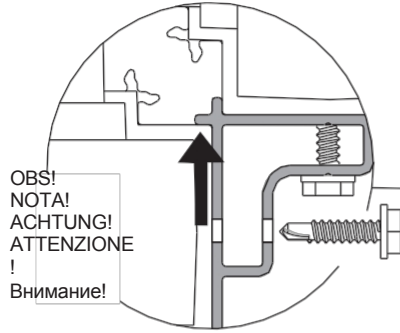
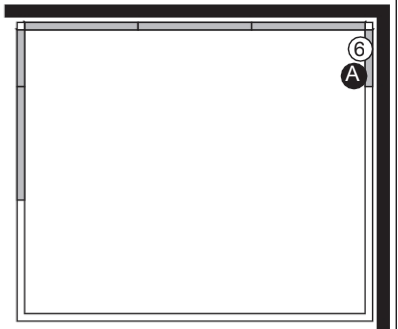

OBS!  
 NOTA!  
 ACHTUNG!  
 ATTENZIONE!  
 Внимание!

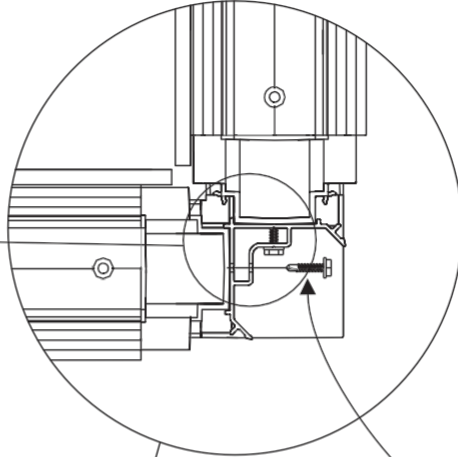

x4

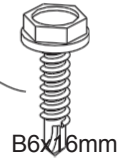

Utsida  
 Outside  
 Außenseite  
 Extérieur  
 Наруж.  
 Na zewnątrz

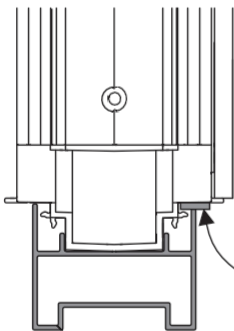

Insida  
 Inside  
 Innenseite  
 Intérieur  
 Внутр.  
 Wewnątrz

Imballaggio  
 Imballaggio  
 Dichtung  
 Joint  
 Прокладка  
 Uszczelka

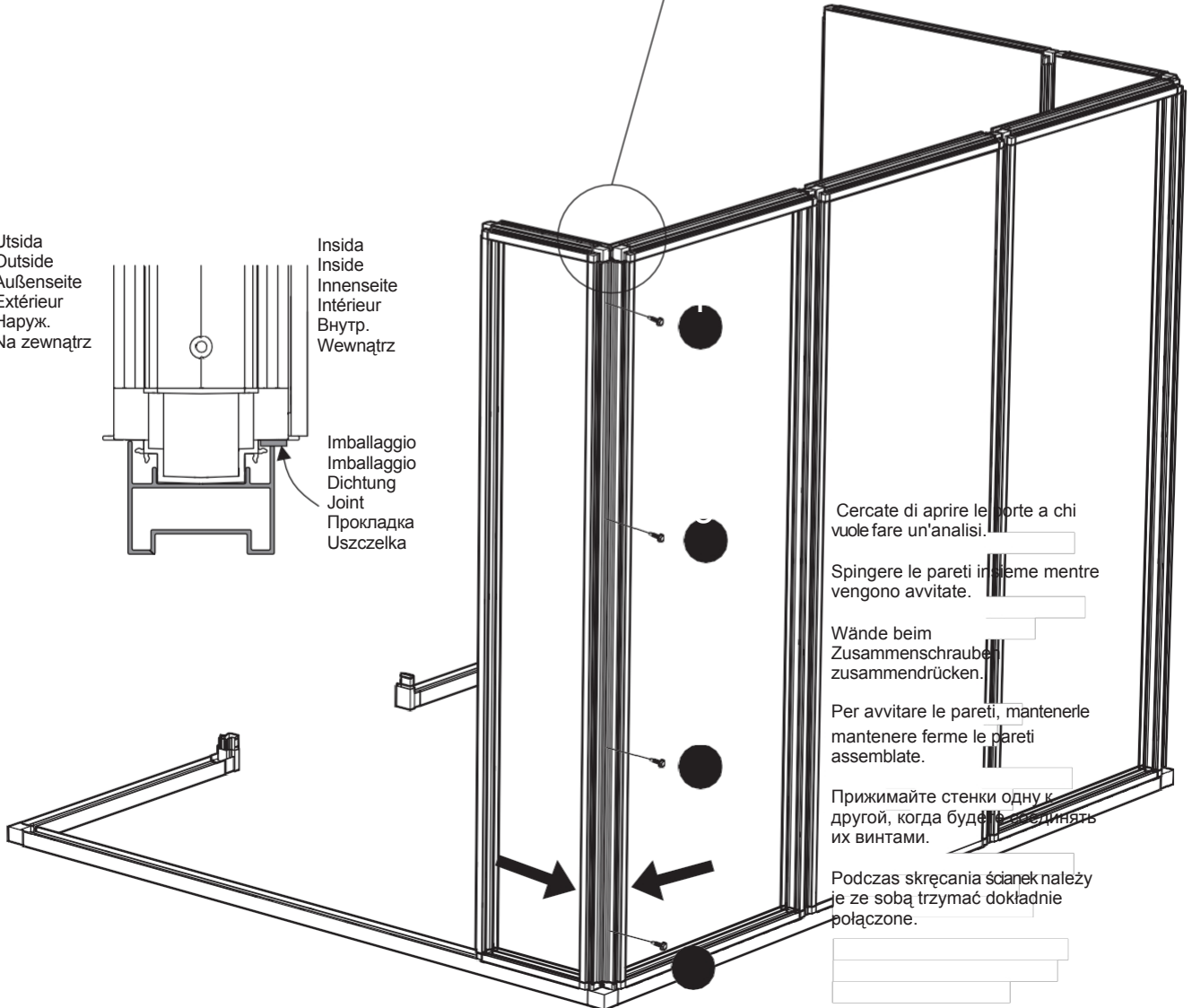

Cercate di aprire le porte a chi vuole fare un'analisi.

Spingere le pareti insieme mentre vengono avvitate.

Wände beim Zusammenschrauben zusammendrücken.

Per avvitare le pareti, mantenerle mantenere ferme le pareti assemblate.

Прижимайте стенки одну к другой, когда будете соединять их винтами.

Podczas skręcania ścianek należy je ze sobą trzymać dokładnie połączone.

20

Piastra di  
bloccaggio  
Sicurezza  
Rondella di bloccaggio  
Направление  
Płytki blokująca  
x1

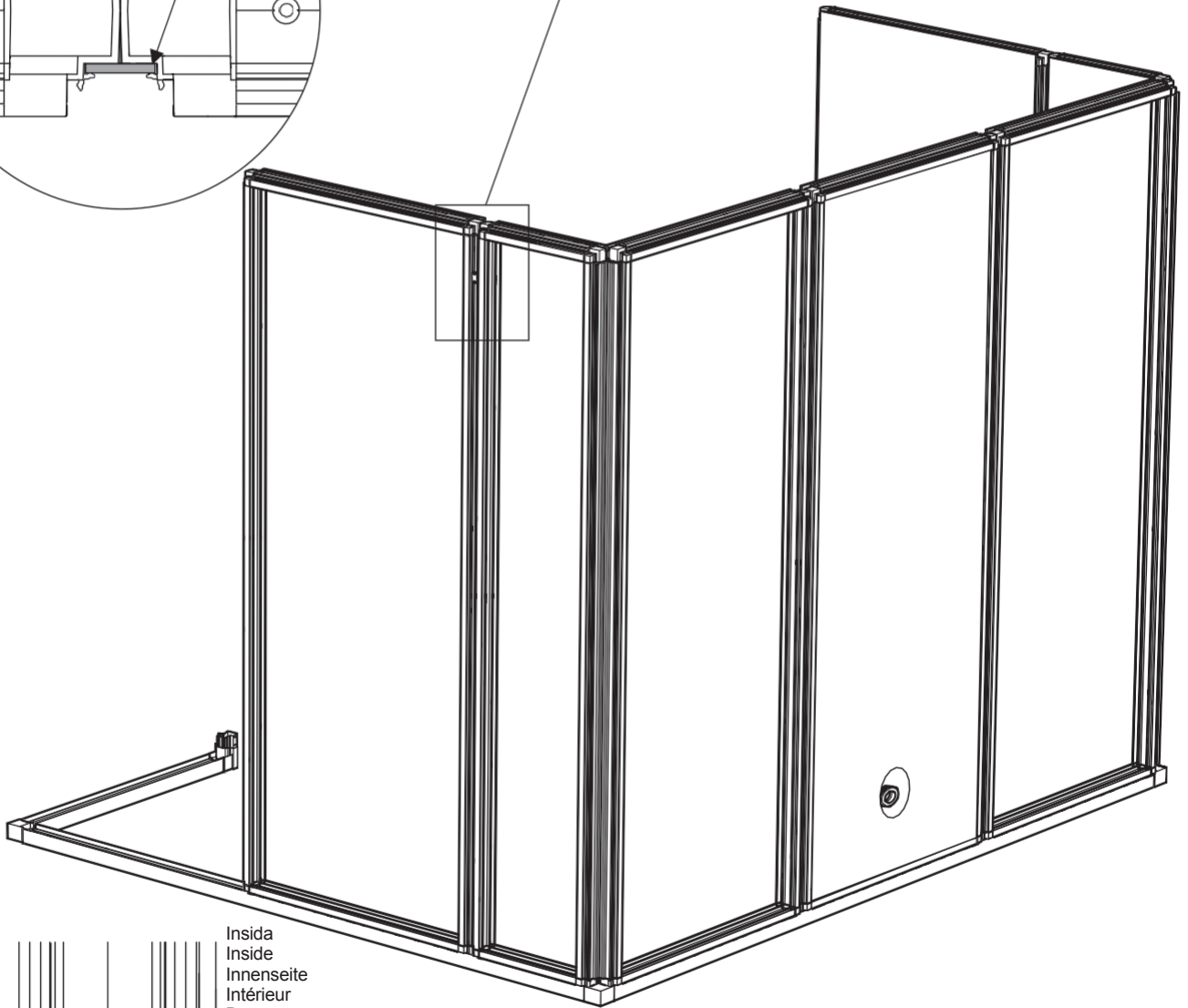
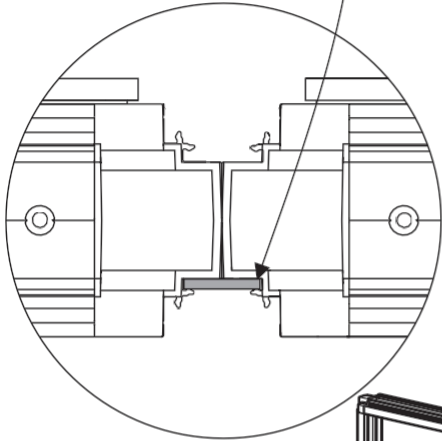
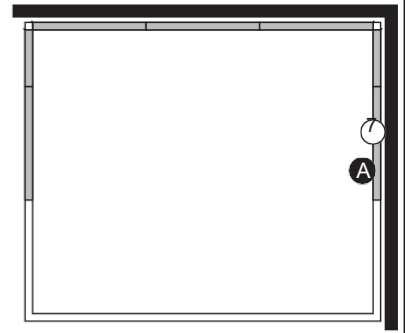
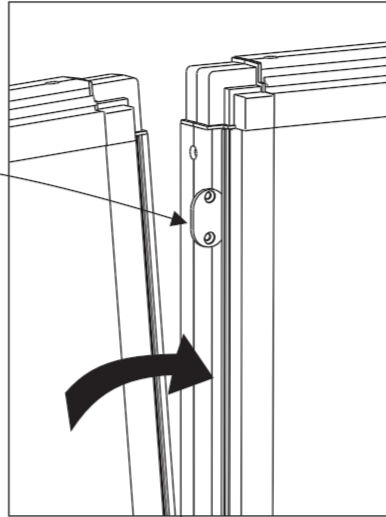
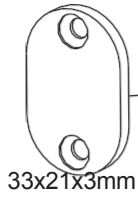

Utsida  
Outside  
Außenseite  
Extérieur  
Наруж.  
Na zewnątrz

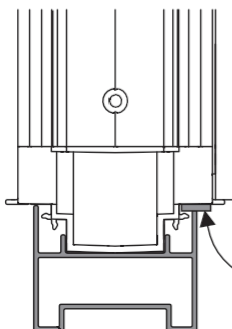

Insida  
Inside  
Innenseite  
Intérieur  
Внутр.  
Wewnątrz

Imballaggio  
Imballaggio  
Dichtung  
Giunto  
Прокладка  
Uszczelka

21

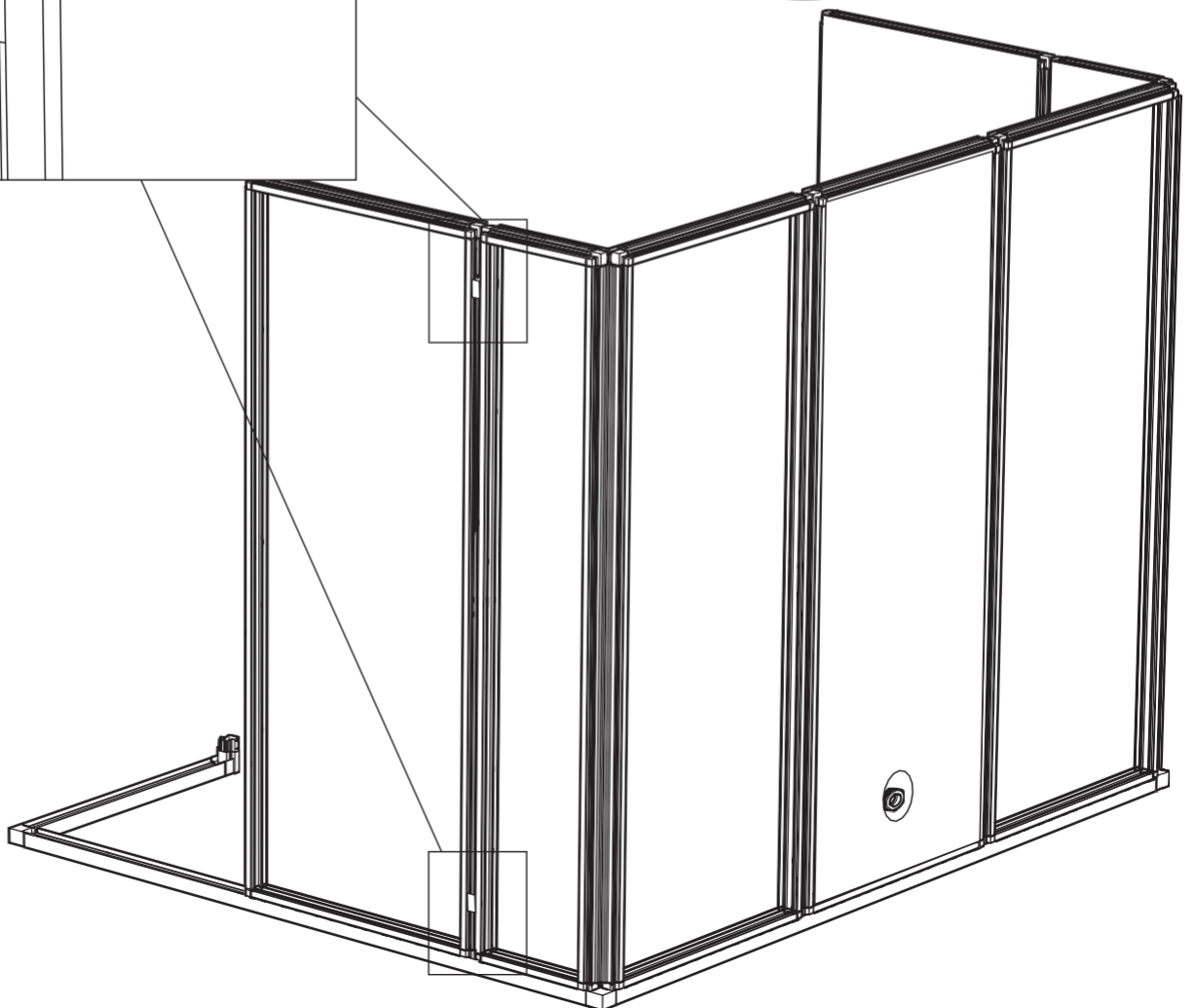
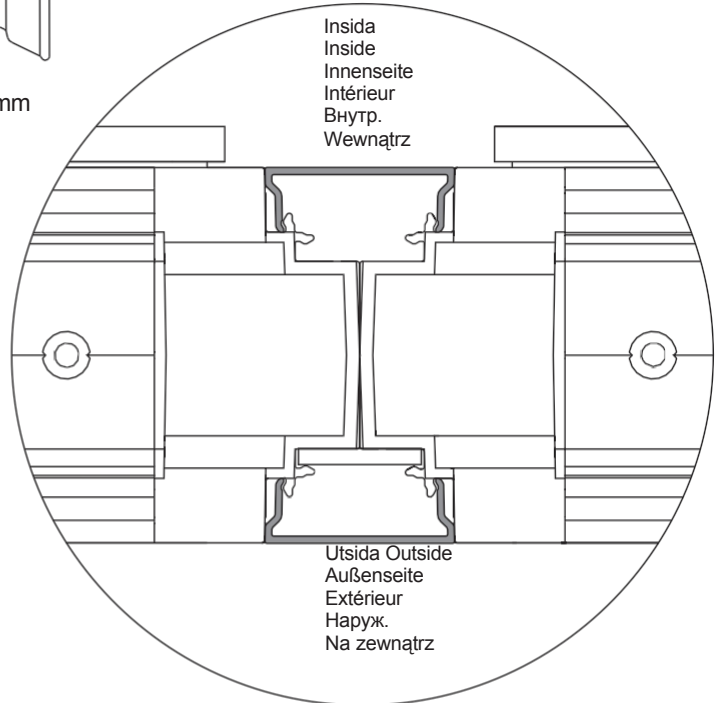
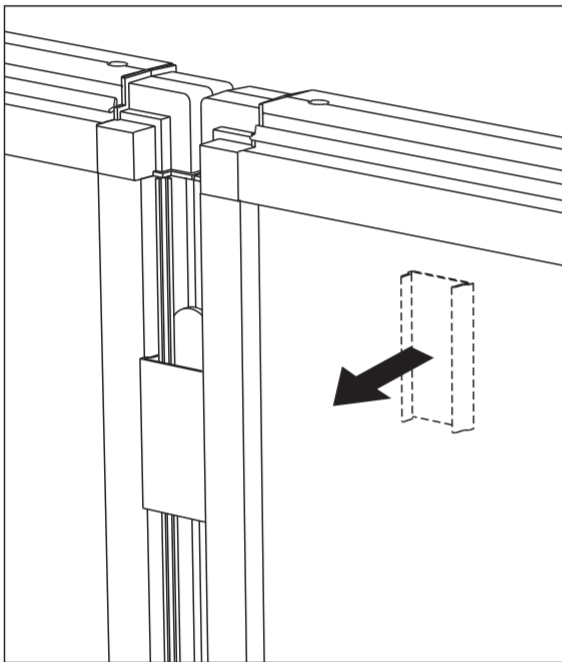
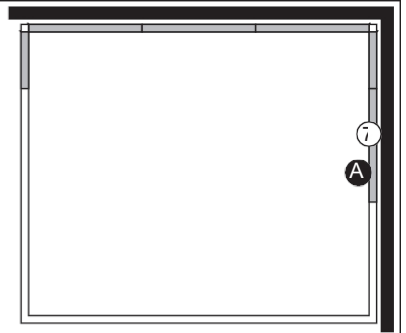
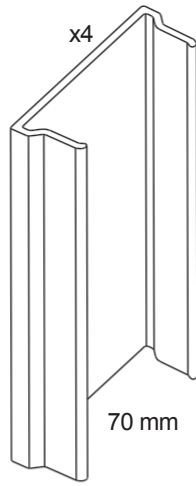

22

P2

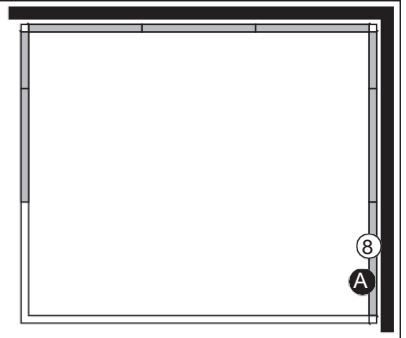
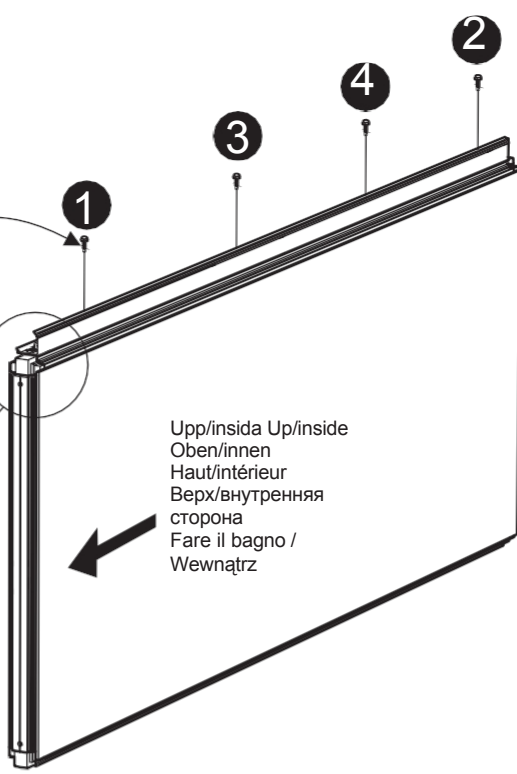
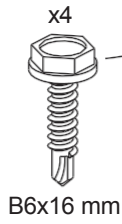
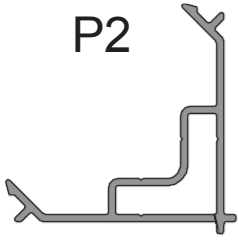

Upp/insida Up/inside  
Oben/innen  
Haut/intérieur  
Верх/внутренняя  
сторона  
Fare il bagno /  
Wewnątrz

Utsida  
Outside  
Außenseite  
Extérieur  
Наруж.  
Na zewnątrz

Insida  
Inside  
Innenseite  
Intérieur  
Внутр.  
Wewnątrz

Upp  
Up  
Oben  
Haut  
Верх  
Fai da te

OBS!  
NOTA!  
ACHTUNG!  
ATTENZIONE  
!  
Внимание!

Kant i kant Flush  
fit Kantenbündig  
Bord à bord  
Край к краю.  
Wyrównać

Upp/insida Up/inside  
Oben/innen  
Haut/intérieur  
Верх/внутренняя  
сторона  
Do góry/Wewnątrz

Insida  
Inside  
Innenseite  
Intérieur  
Внутр.  
Wewnątrz

Utsida Outside  
Außenseite  
Extérieur  
Наруж.  
Na zewnątrz

Nej  
Down  
Unten  
Bas  
Низ  
Na dół

23

Styrning Piastra  
di bloccaggio  
Sicherungsscheibe  
Rondelle de blocage  
Направление Плитка  
blokujaća  
x1

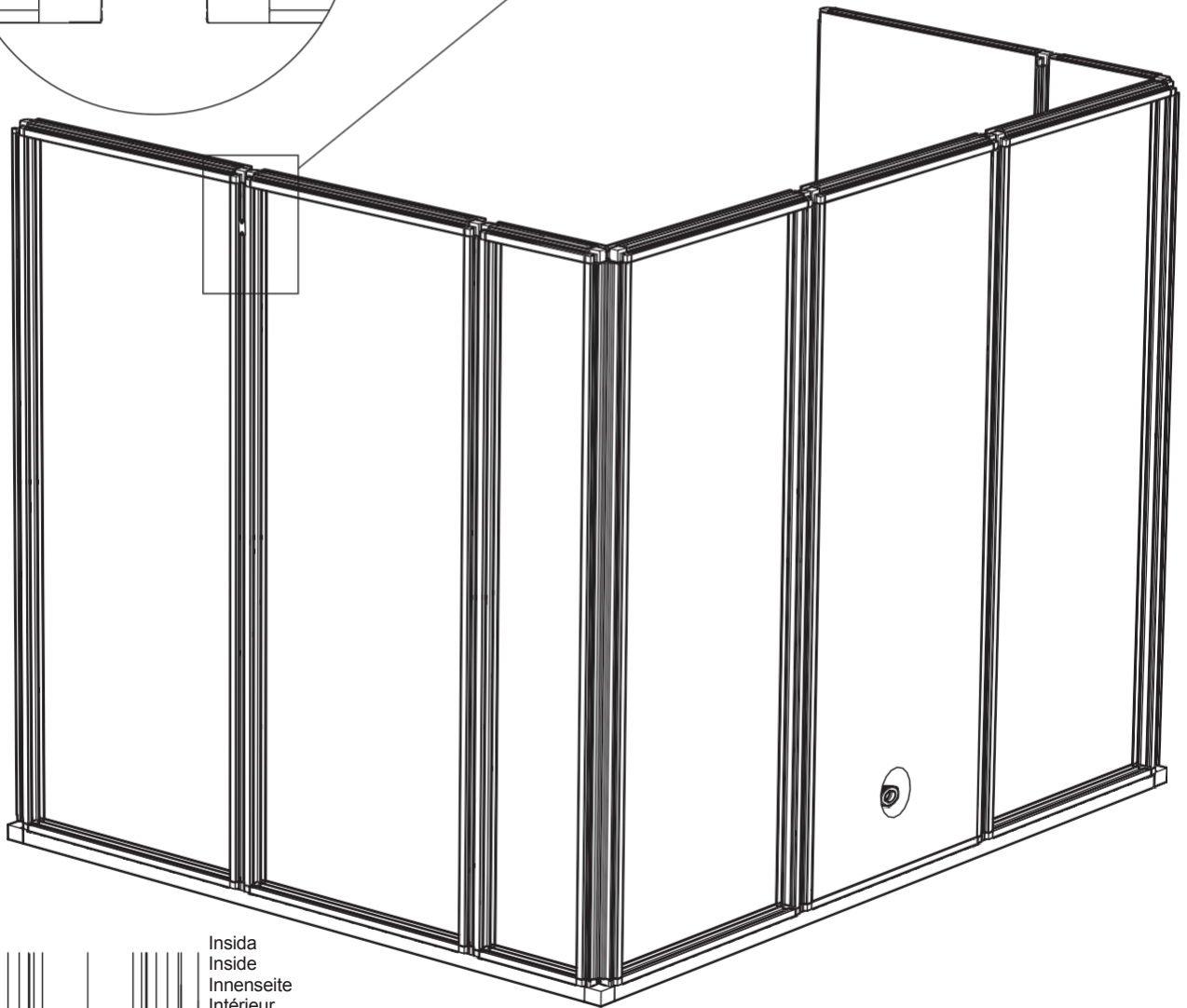
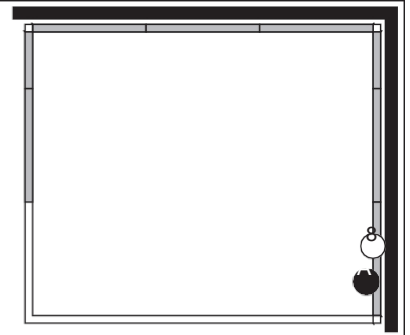
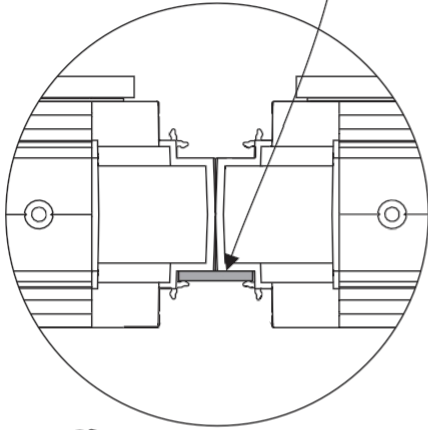
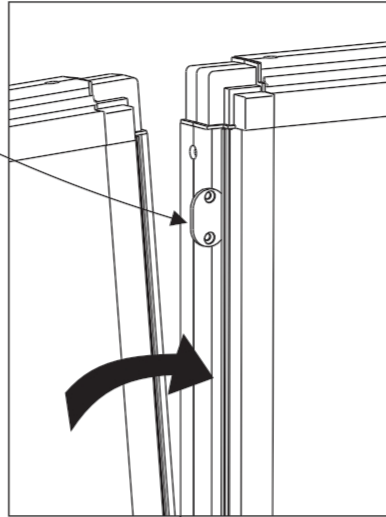
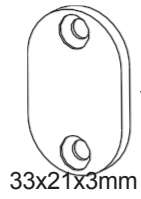

Utsida  
Outside  
Außenseite  
Extérieur  
Нарух.  
Na zewnątrz

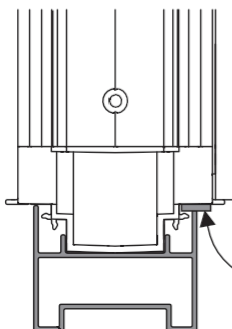

Insida  
Inside  
Innenseite  
Intérieur  
Внутр.  
Wewnątrz

Imballaggio  
Imballaggio  
Dichtung  
Giunto  
Прокладка  
Uszczelka

24

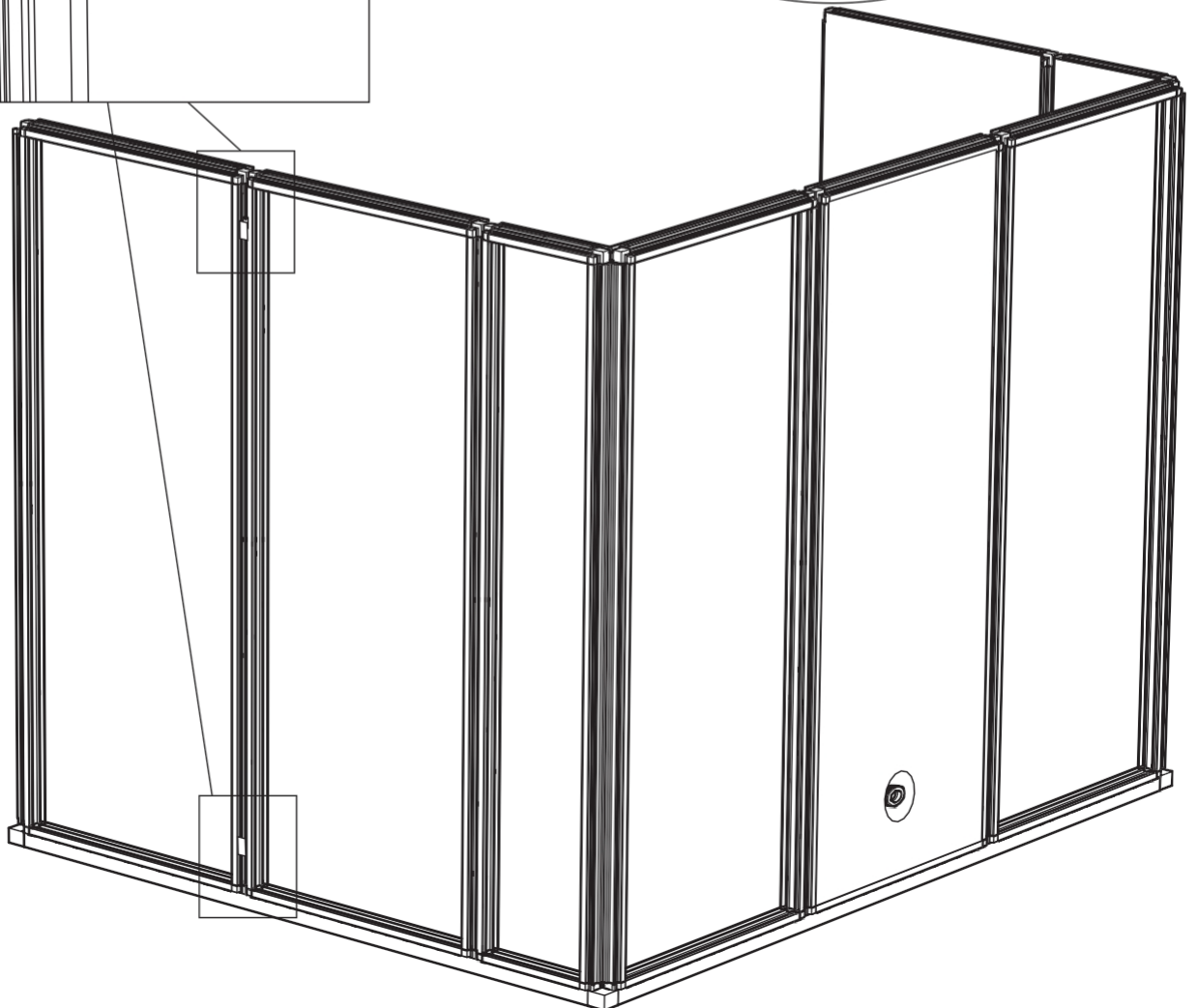
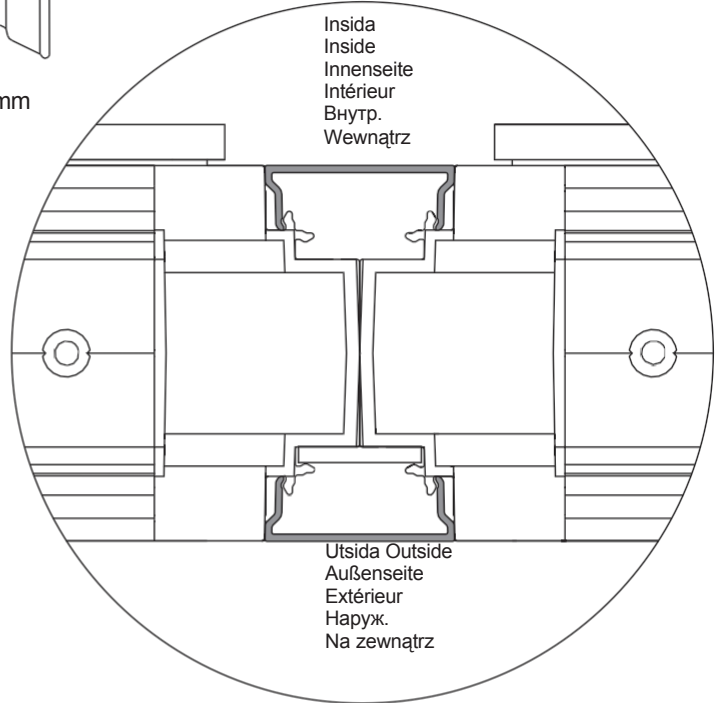
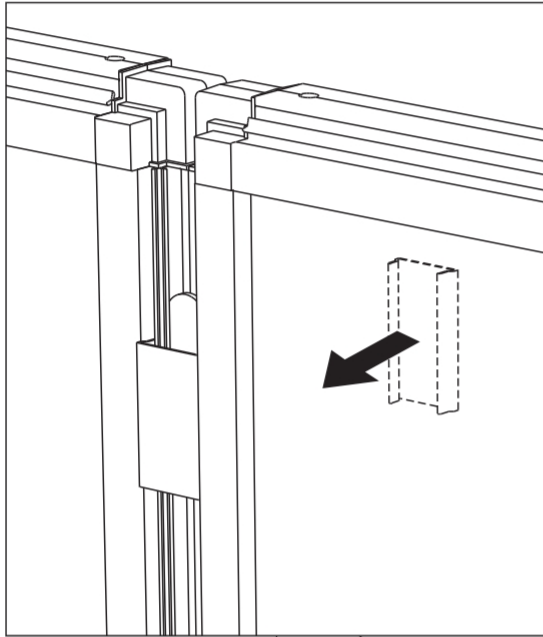
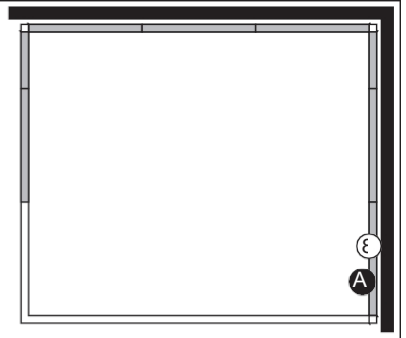
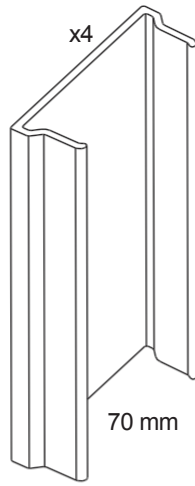

25

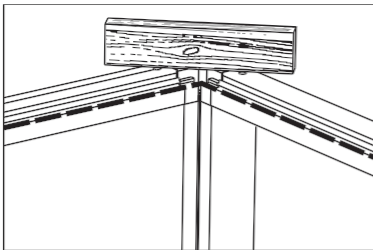

OBS! Det är viktigt att väggarna är i jämnhöjd i hörnen.  
 IMPORTANTE! Le pareti devono essere perfettamente in piano nel punto di incontro con gli angoli.  
 ACHTUNG! Le pareti devono essere perfettamente livellate in corrispondenza degli angoli.  
 ATTENZIONE! È importante che le cloisons siano allo stesso livello negli angoli.  
 Внимание! Важно, чтобы стенки были на одинаковой высоте в углу.  
 WAŻNE! Ścianki w narożniku muszą być dokładnie na tym samym poziomie.

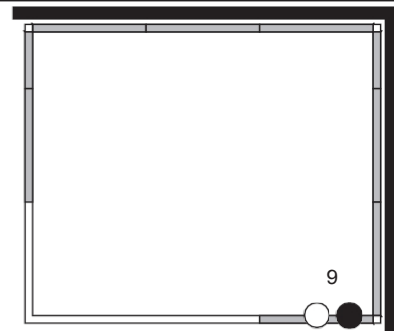

OBS!  
 NOTA!  
 ACHTUNG!  
 ATTENZIONE!  
 Внимание!

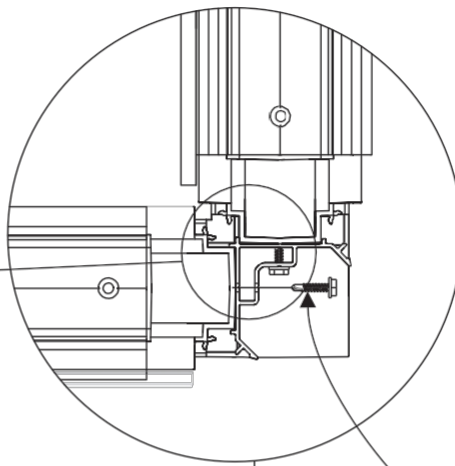
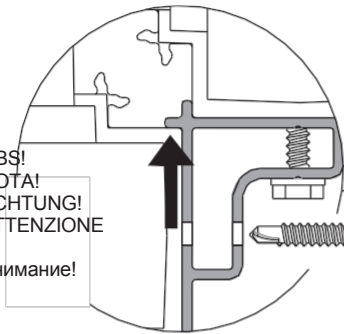

x4

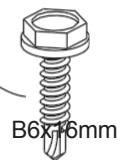

B6x16mm

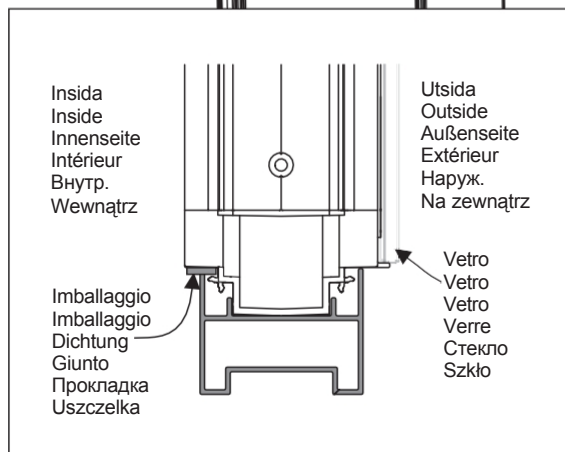

Cercate di tenere un dito su  
 väggarna quando si tratta di un  
 samman.

Spingere le pareti insieme mentre  
 vengono avvitate.

Wände beim Zusammenschrauben  
 zusammen drücken.

Per vivere le pareti, mantenerle  
 ferme e assemblate.

Прижимайте стенки одну к  
 другой, когда будете соединять  
 их винтами.

Podczas ściskania panek należy  
 je ze sobą trzymać

dokładnie połączone.

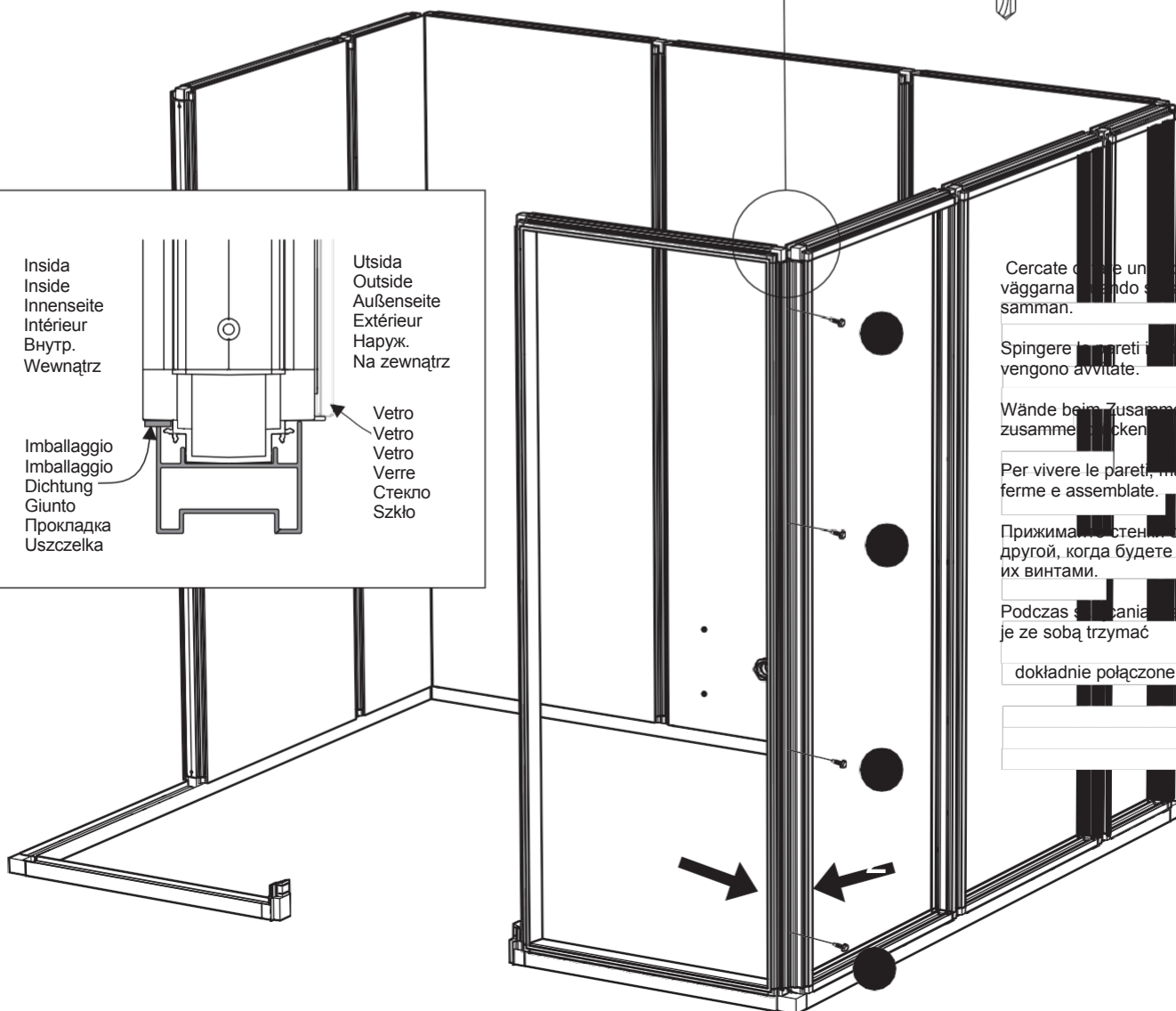

26

P2

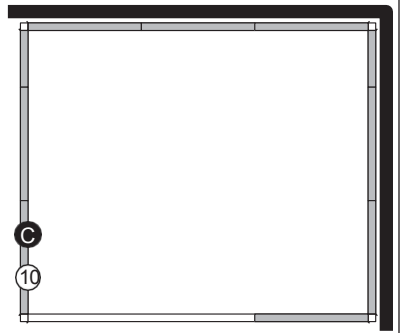
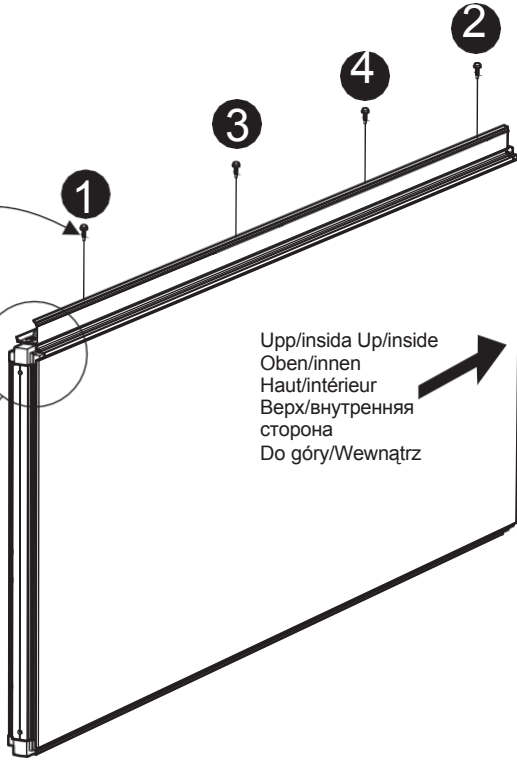
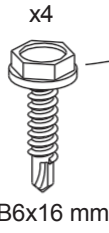
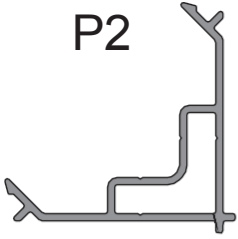

Utsida  
Outside  
Außenseite  
Extérieur  
Наруж.  
Na zewnątrz

Insida  
Inside  
Innenseite  
Intérieur  
Внутр.  
Wewnątrz

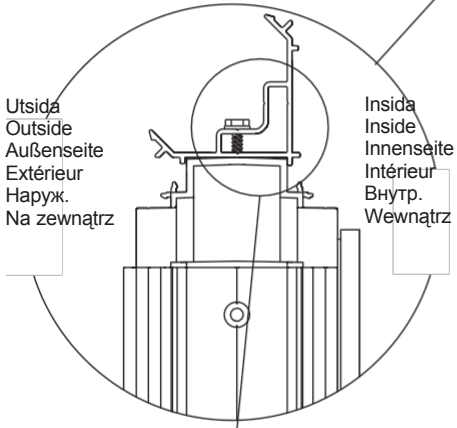

OBS!  
NOTA!  
ACHTUNG!  
ATTENZIONE  
!  
Внимание!

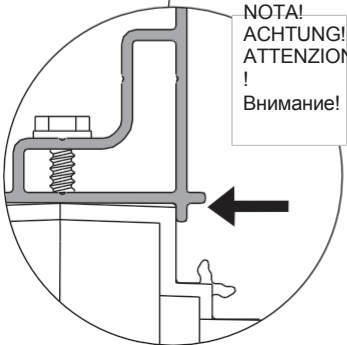

Upp  
Up  
Oben  
Haut  
Верх  
Fare il góry

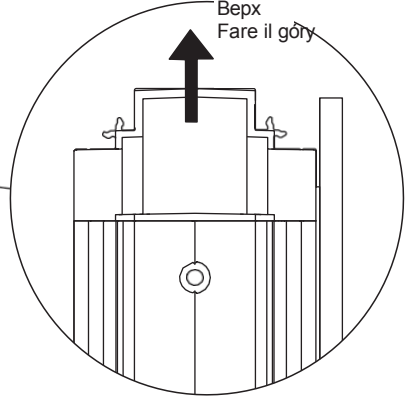

Kant i kant  
Flush fit  
Kantenbündig  
Bord à bord  
Край к краю.  
Wyrównać

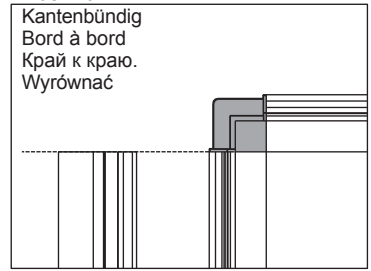

Upp/insida Up/inside  
Oben/innen  
Haut/intérieur  
Верх/внутренняя  
сторона  
Do góry/Wewnątrz

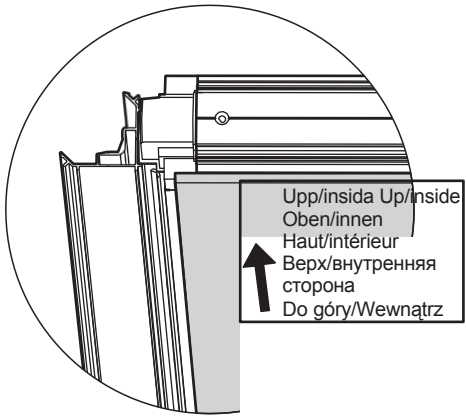

Utsida  
Outside  
Außenseite  
Extérieur  
Наруж.  
Na zewnątrz

Insida  
Inside  
Innenseite  
Intérieur  
Внутр.  
Wewnątrz

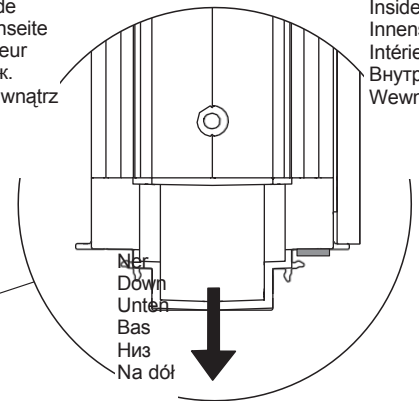

27

Piastra di bloccaggio  
Styrning  
Sicherungsscheibe  
Rondelle de blocage  
Направление Пłyтка  
blokująca

x1

33x21x3mm

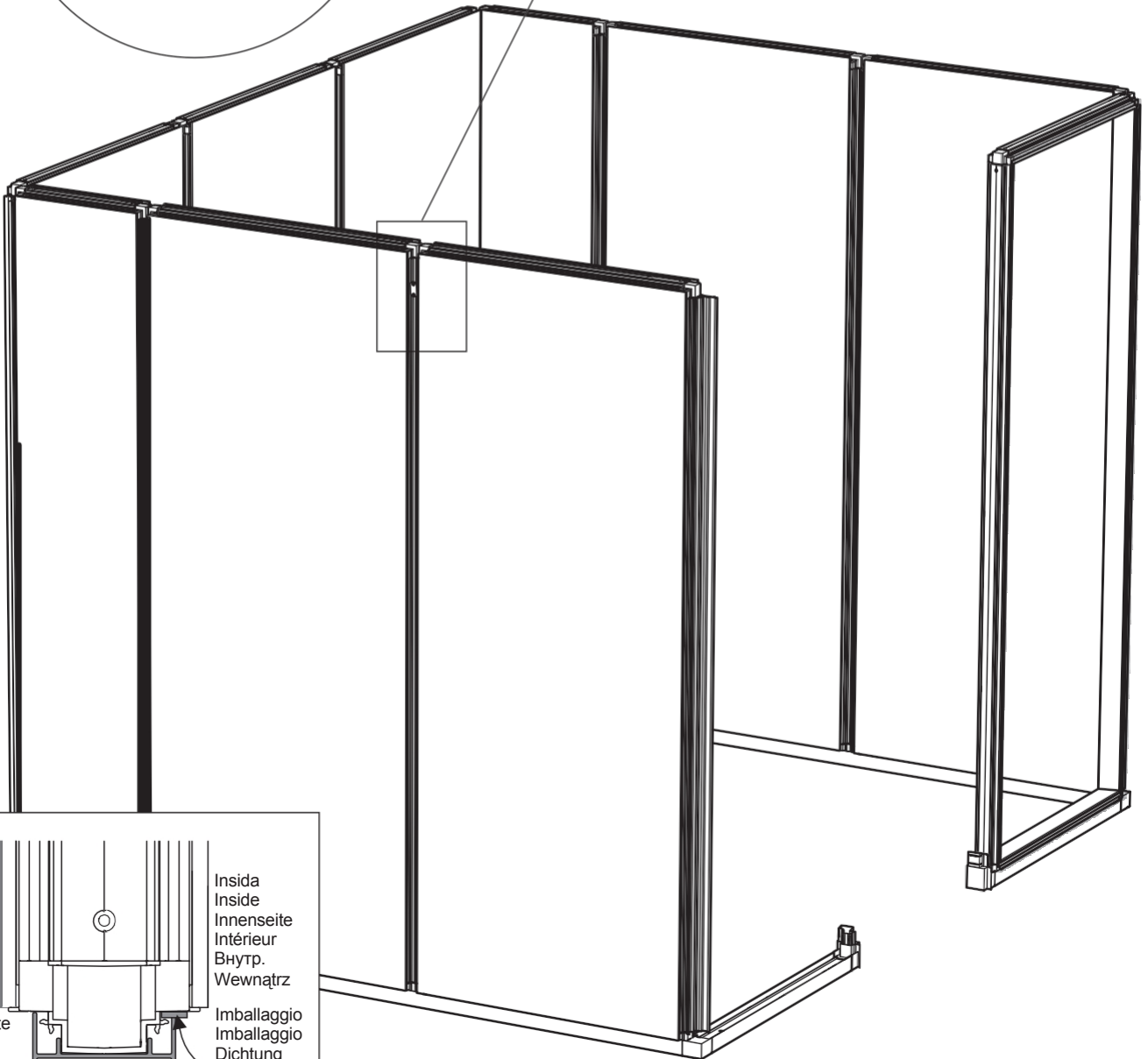
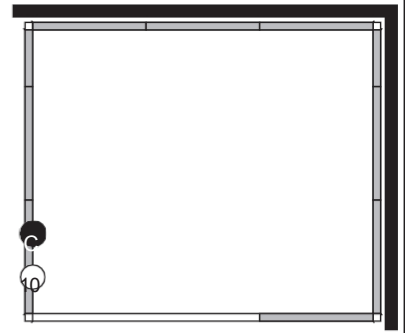
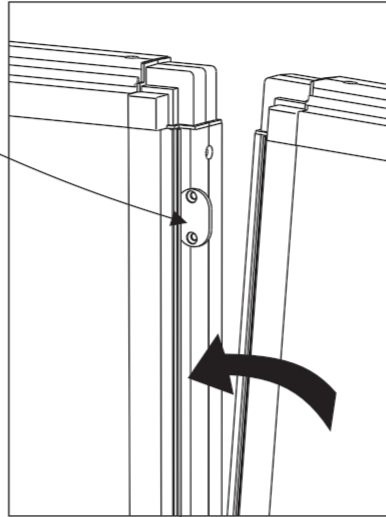
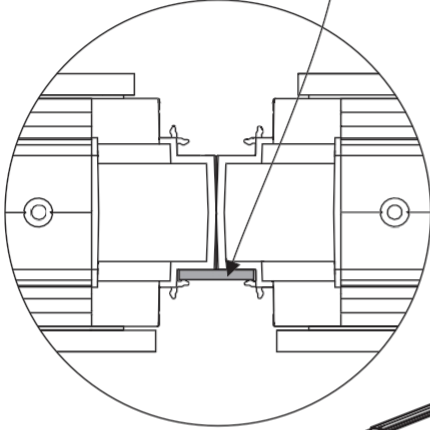

Utsida  
Outside  
Außenseite  
Extérieur  
Наруж.  
Na zewnątrz

Insida  
Inside  
Innenseite  
Intérieur  
Внутр.  
Wewnątrz

Imballaggio  
Imballaggio  
Dichtung  
Giunto  
Прокладка  
Uszczelka

28

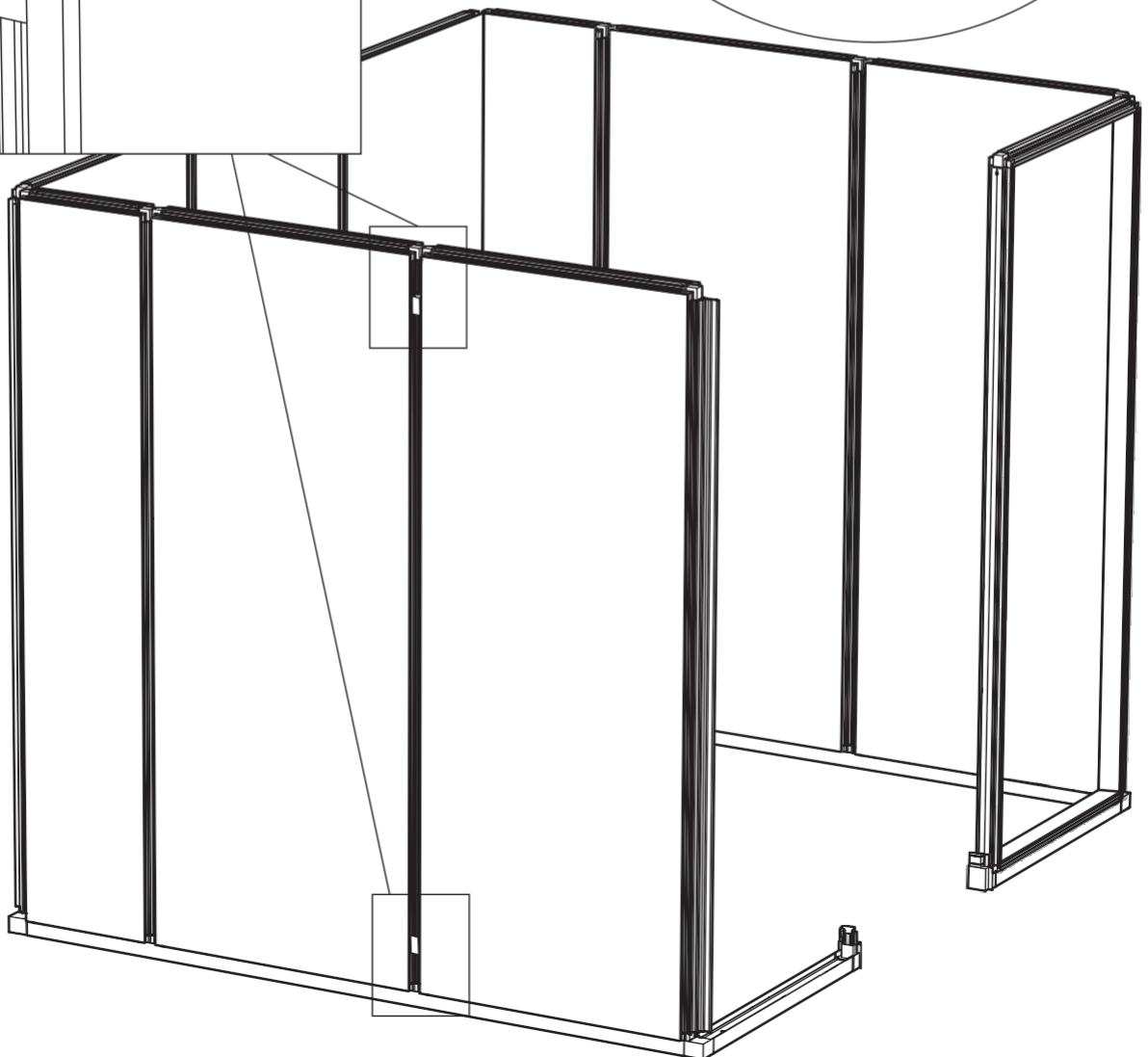
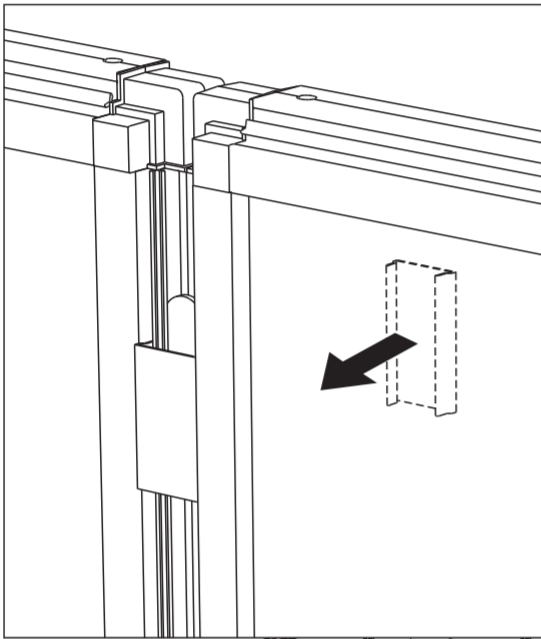
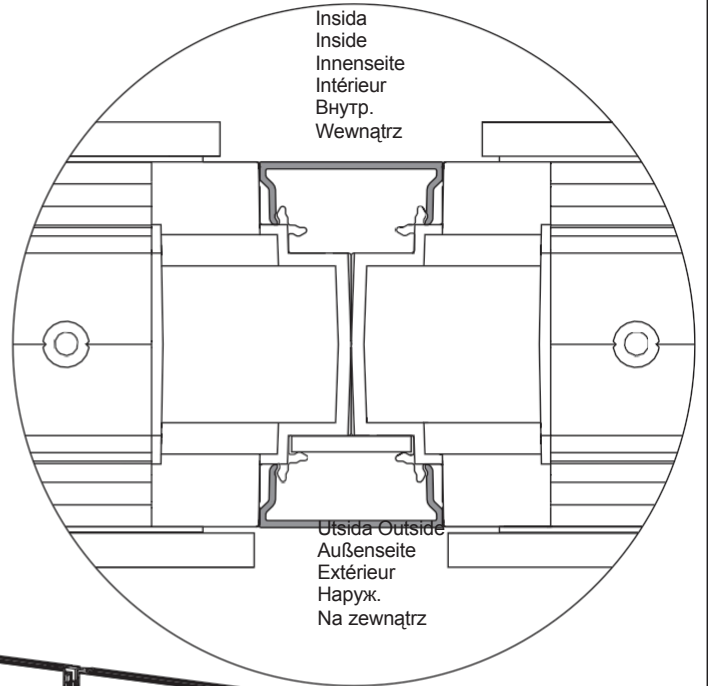
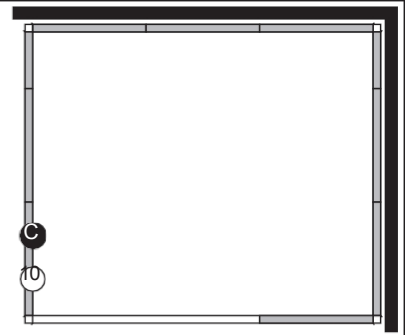
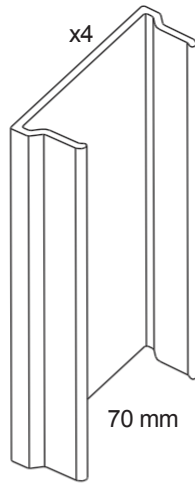

29

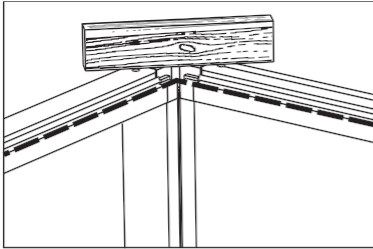

IMPORTANTE! Le pareti devono essere perfettamente in piano nel punto di incontro con gli angoli.

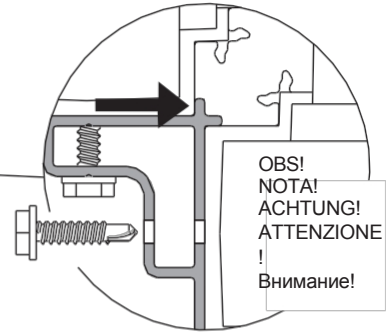
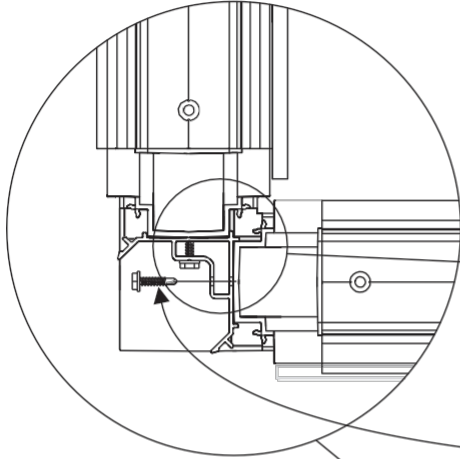
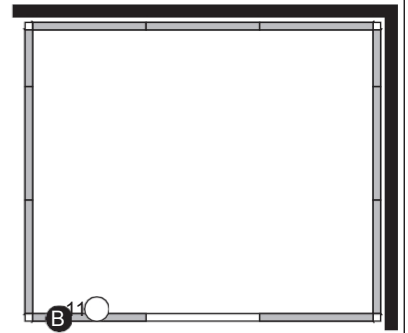

OBS!  
NOTA!  
ACHTUNG!  
ATTENZIONE!  
Внимание!

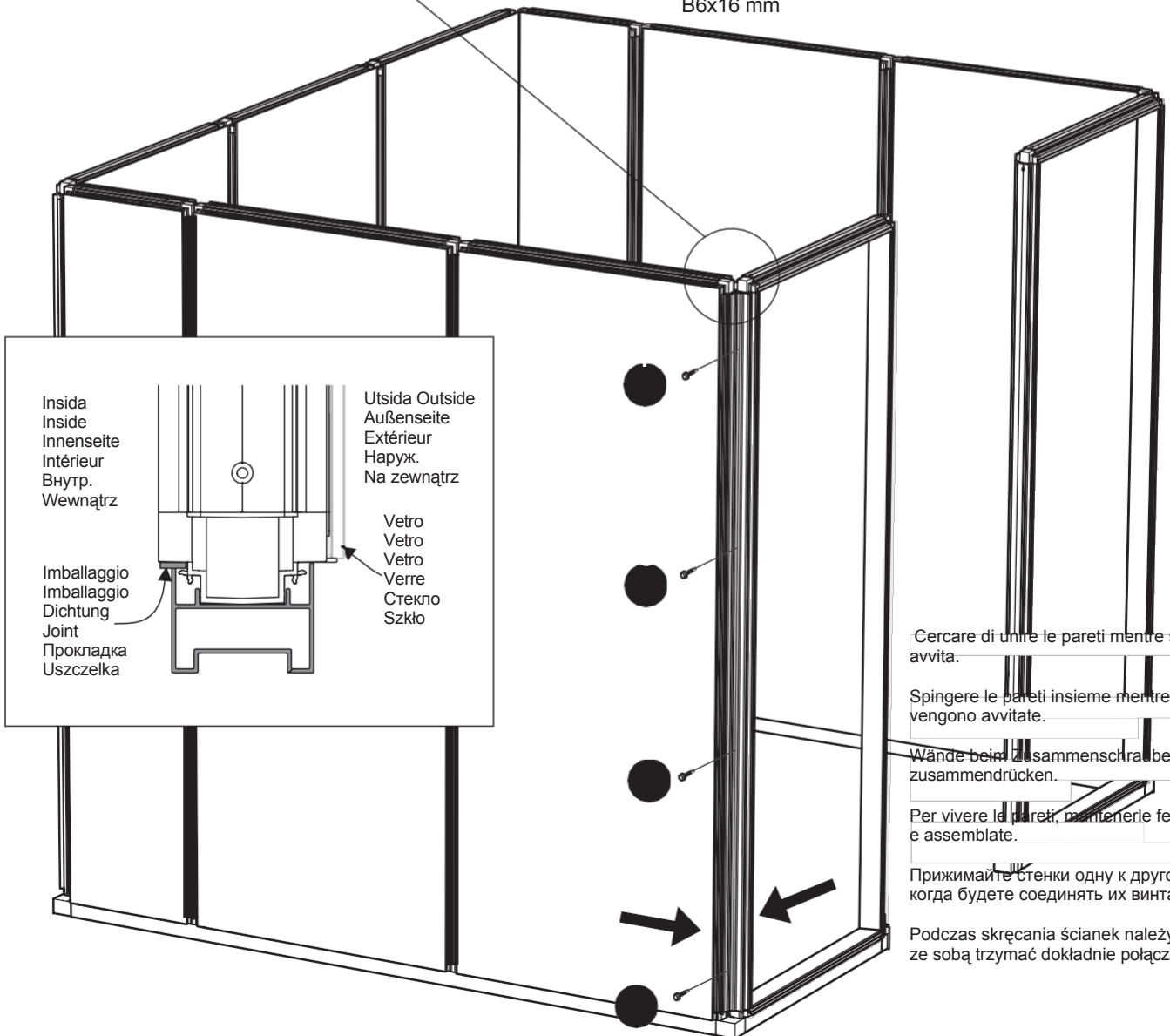
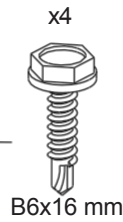

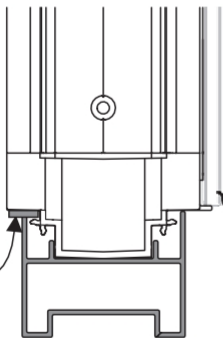
Inside Inside Innenseite Intérieur Внутр. Wewnątrz		Utsida Outside Außenseite Extérieur Наруж. Na zewnątrz
Imballaggio Imballaggio Dichtung Joint Прокладка Uszczelka		Vetro Vetro Vetro Verre Стекло Szkło

Cercare di unire le pareti mentre si avvita.

Spingere le pareti insieme mentre vengono avvitate.

Wände beim Zusammenschrauben zusammendrücken.

Per vivere le pareti, mantenerle ferme e assemblate.

Прижимайте стенки одну к другой, когда будете соединять их винтами.

Podczas skręcania ścianek należy je ze sobą trzymać dokładnie połączone.

P7

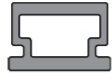

1x1949mm

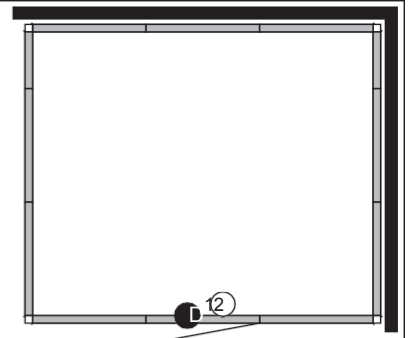

Alt. / Альт. / Wer.

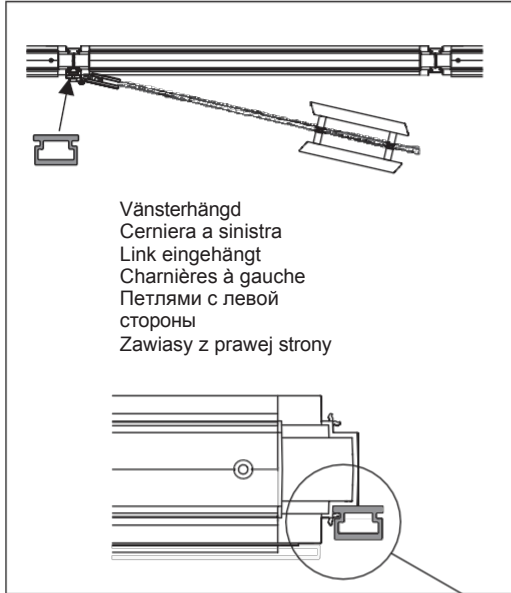

Vänsterhängd  
Cerniera a sinistra  
Link eingehängt  
Charnières à gauche  
Петлями с левой стороны  
Zawiasy z prawej strony

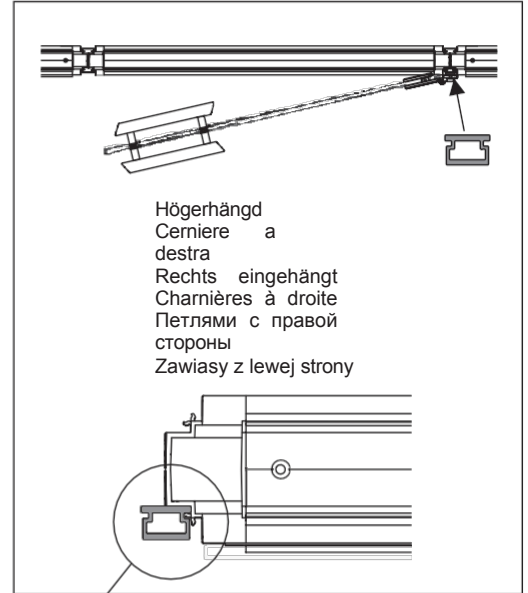

Högerhängd  
Cerniere a destra  
Rechts eingehängt  
Charnières à droite  
Петлями с правой стороны  
Zawiasy z lewej strony

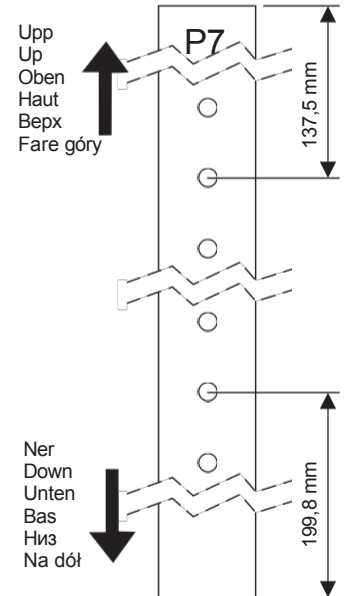
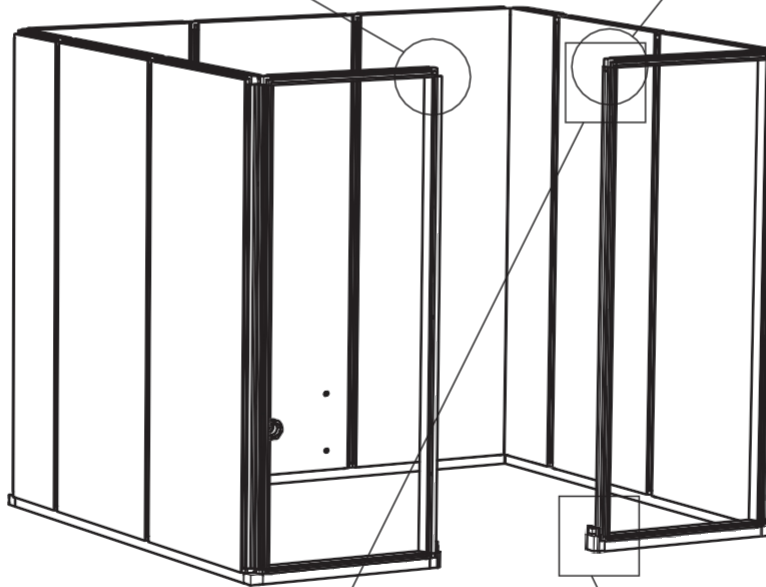

Utilizzare il nastro adesivo per tenere il profilo temporaneamente in posizione.

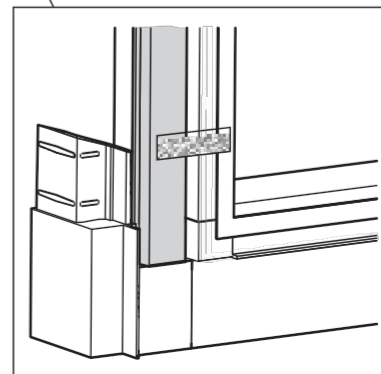
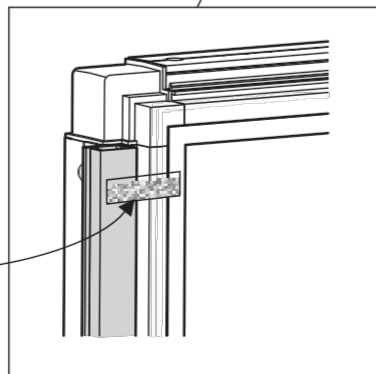

Insida  
Inside  
Innenseite  
Intérieur  
Внутр.  
Wewnątrz

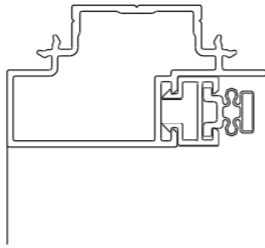

Utsida  
Outside  
Außenseite  
Extérieur  
Наруж.  
Na zewnątrz

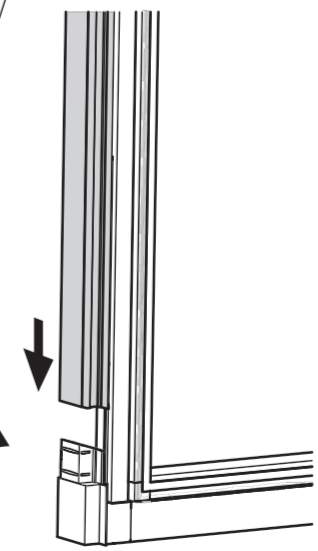
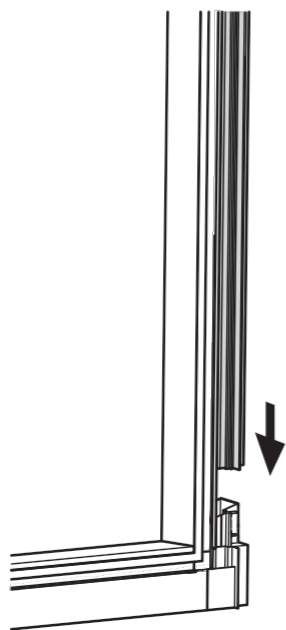
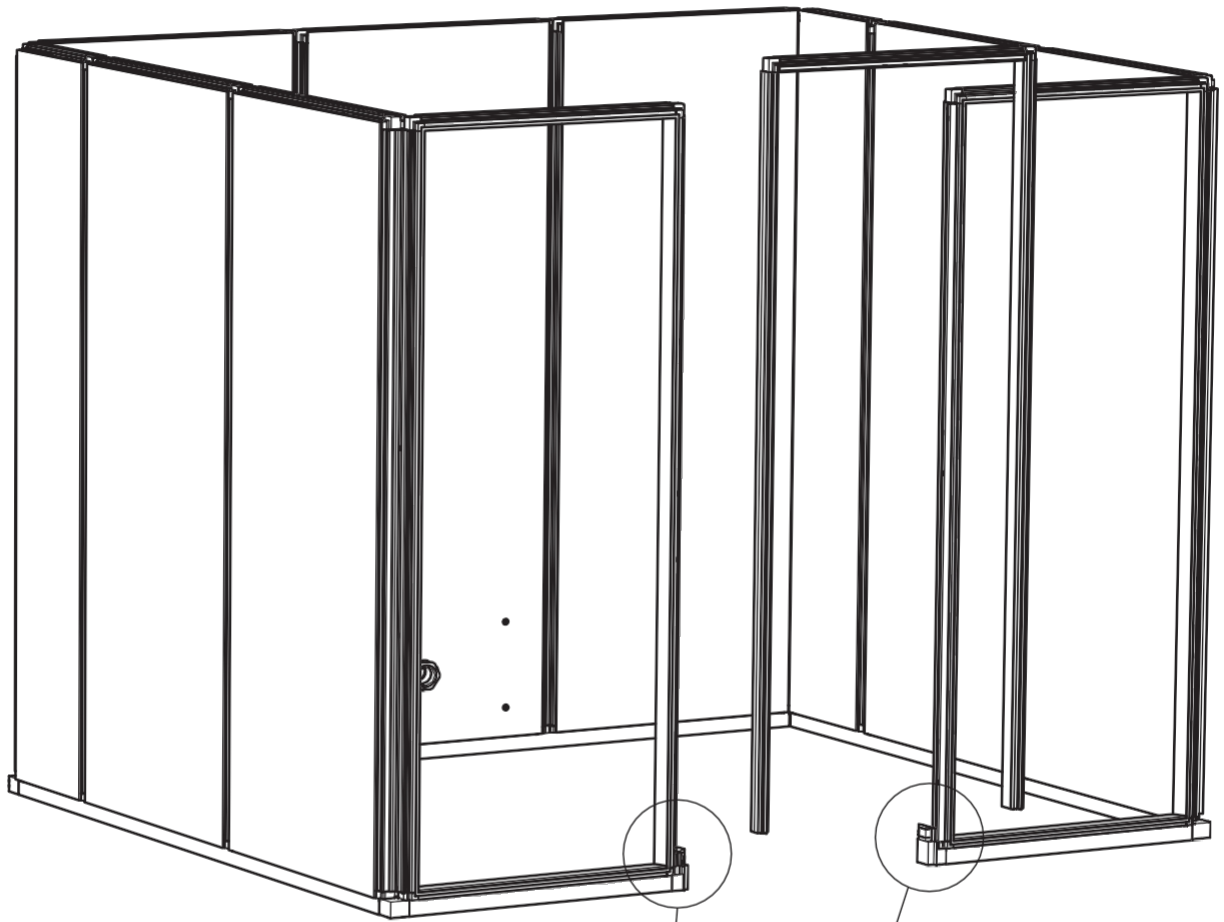
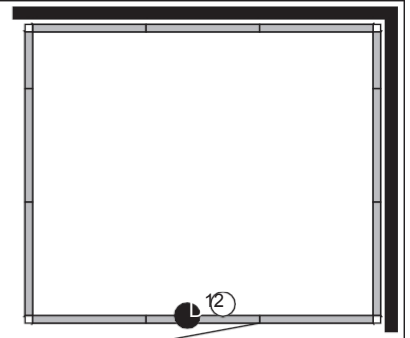

Piastra di bloccaggio  
Sicherungsscheibe  
Rondelle de blocage  
Направление Плитка  
blokujaça

x1

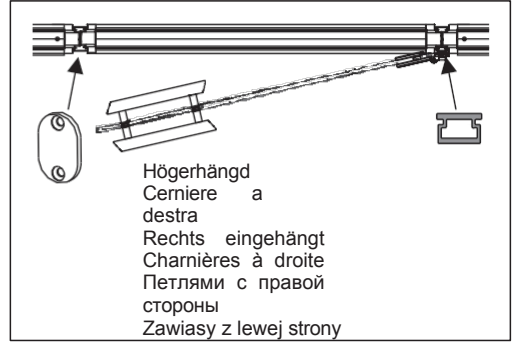
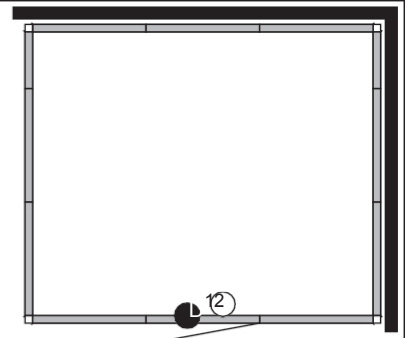
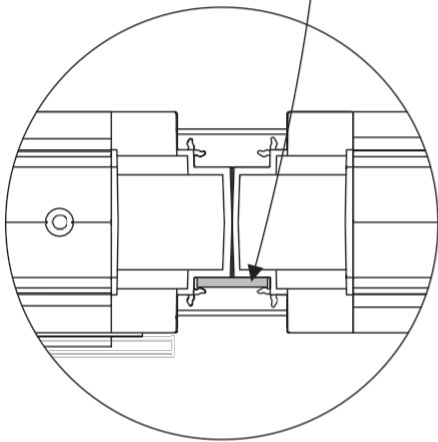
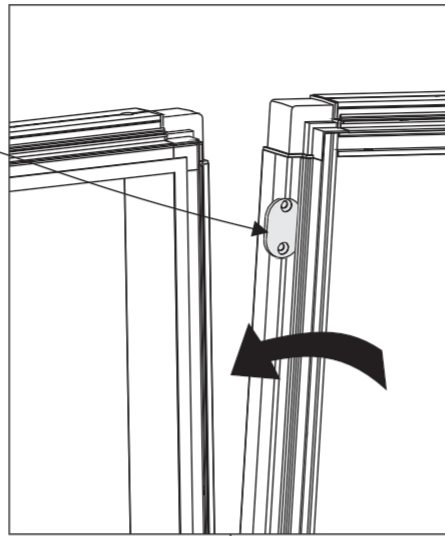

**Alt. / Альт. / Wer.**

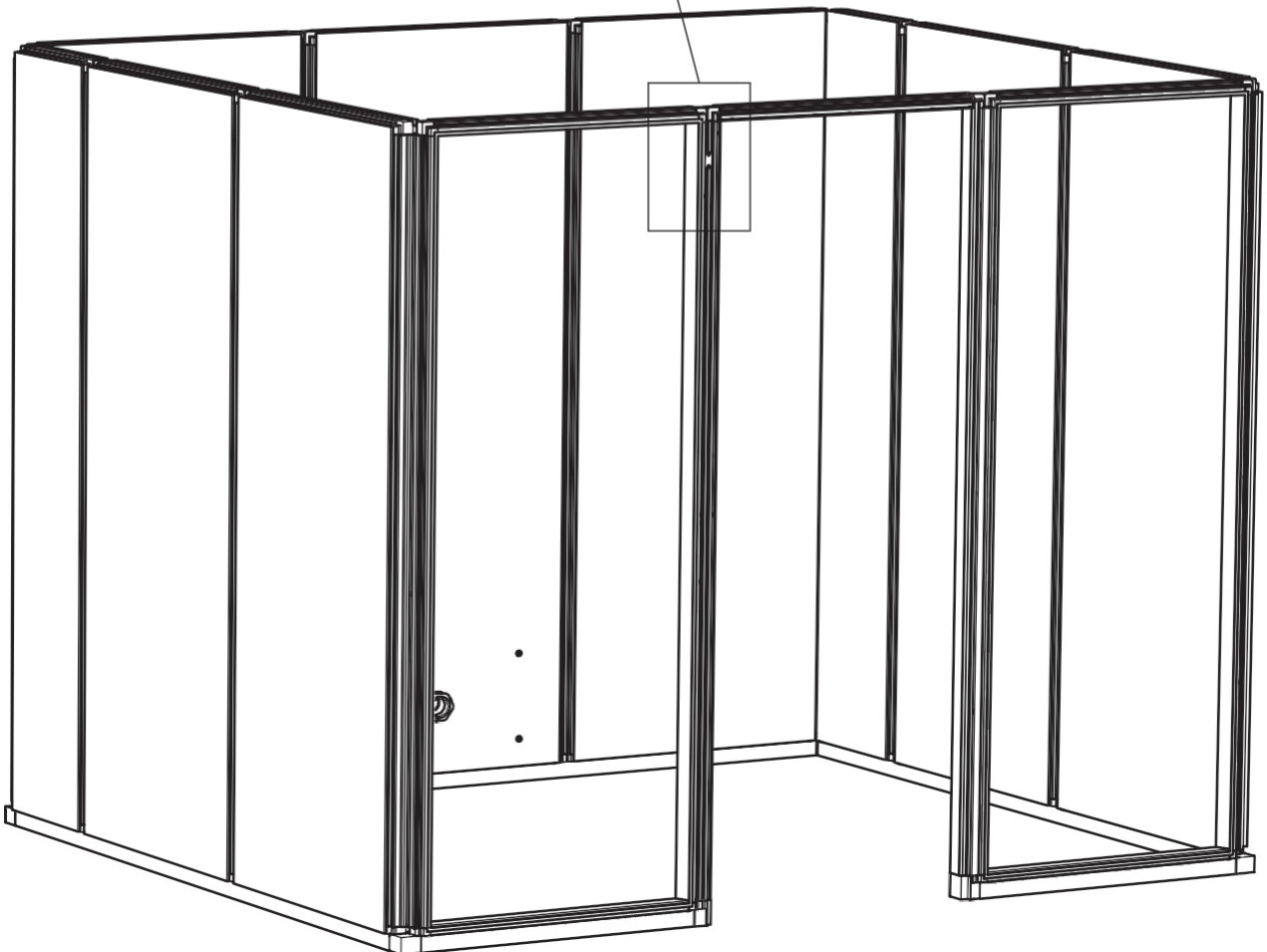
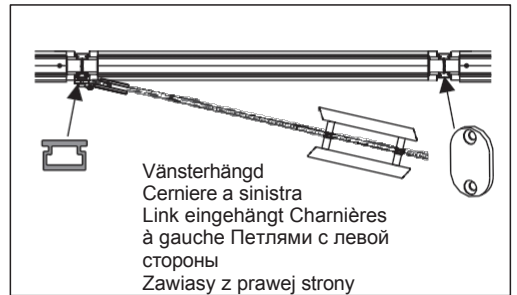

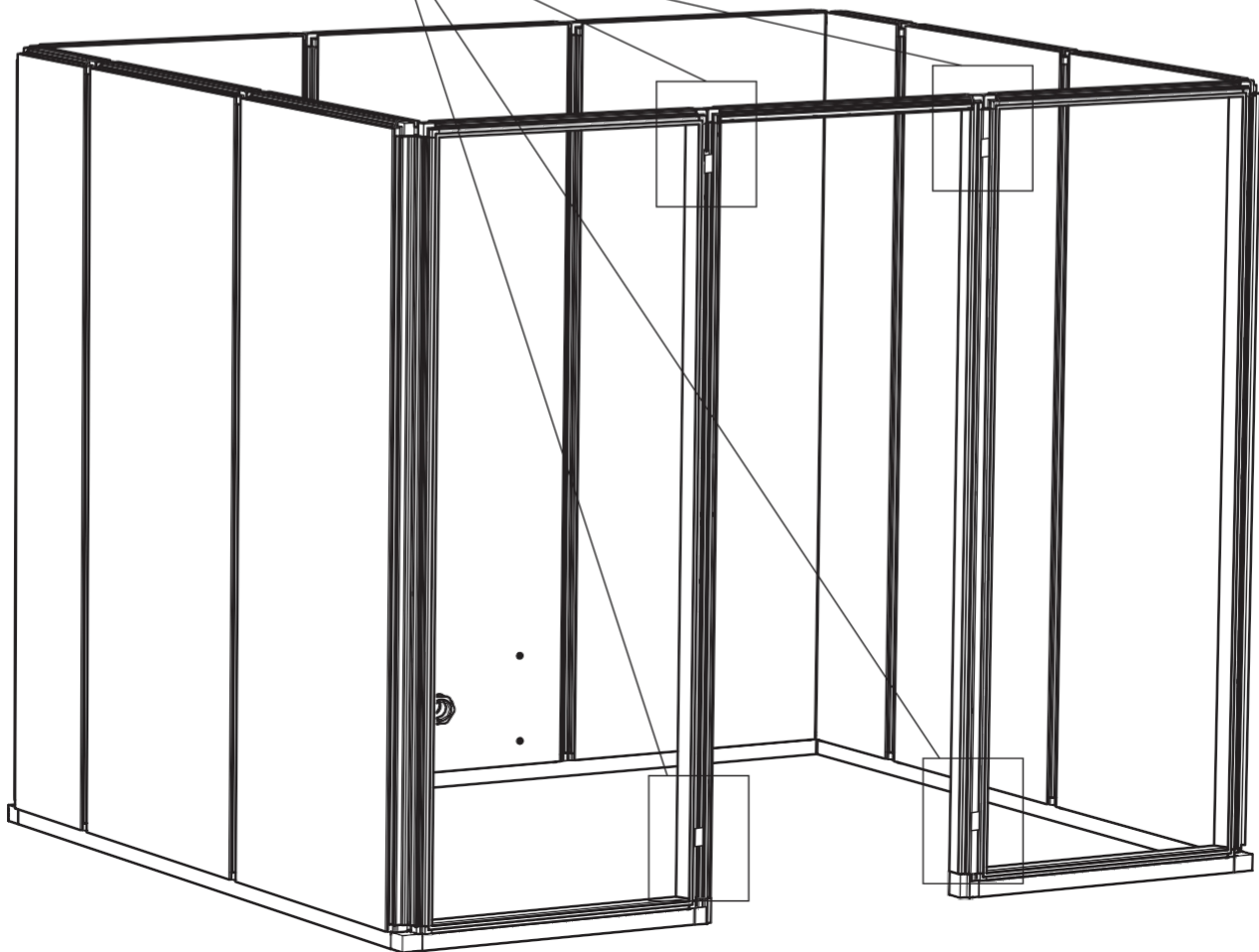
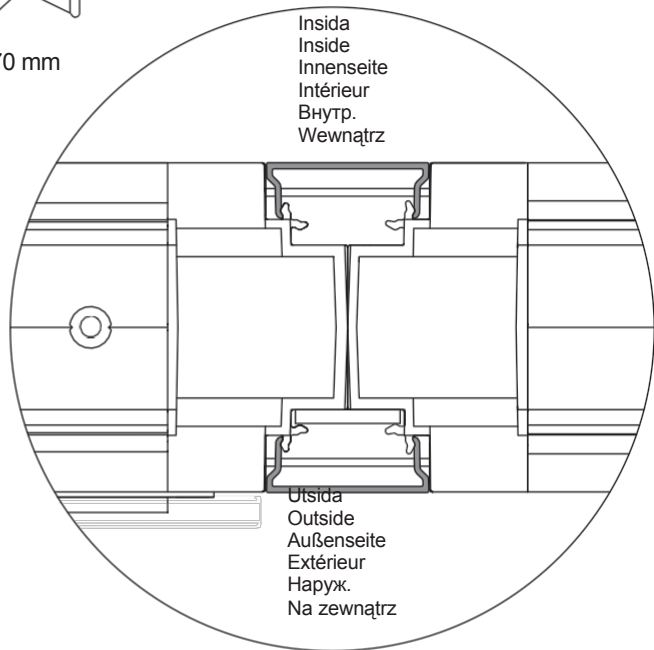
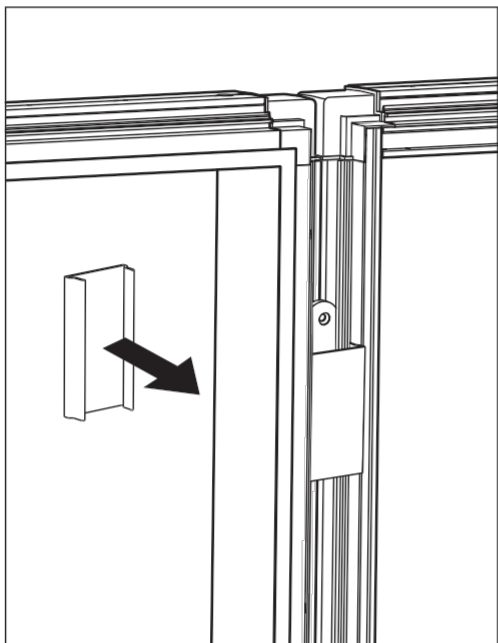
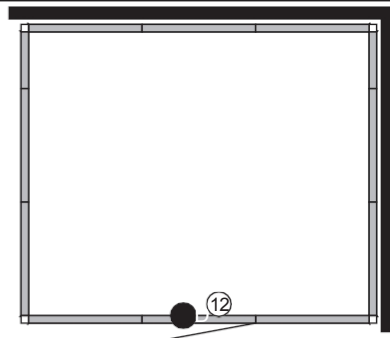
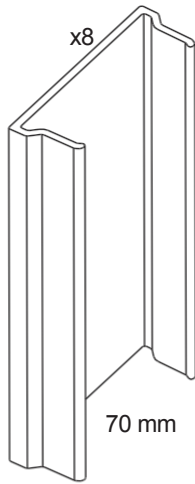

34

P6



2x1968mm  
2x2368mm

Självhäftande  
Autoadesivo  
Selbstklebend  
Autocollant  
Самоприклеивающиеся Samoprzyklepne

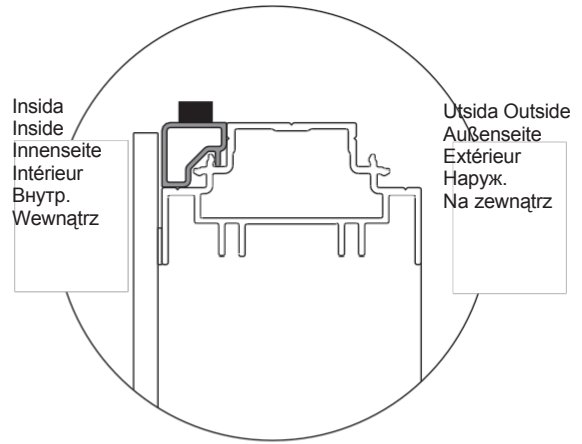
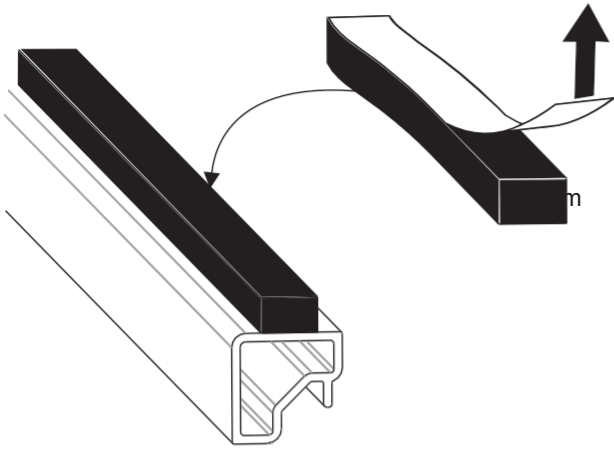

Insida  
Inside  
Innenseite  
Intérieur  
Внутр.  
Wewnařrz

Utsida  
Outside  
Außenseite  
Extérieur  
Наруж.  
Na zewnařrz

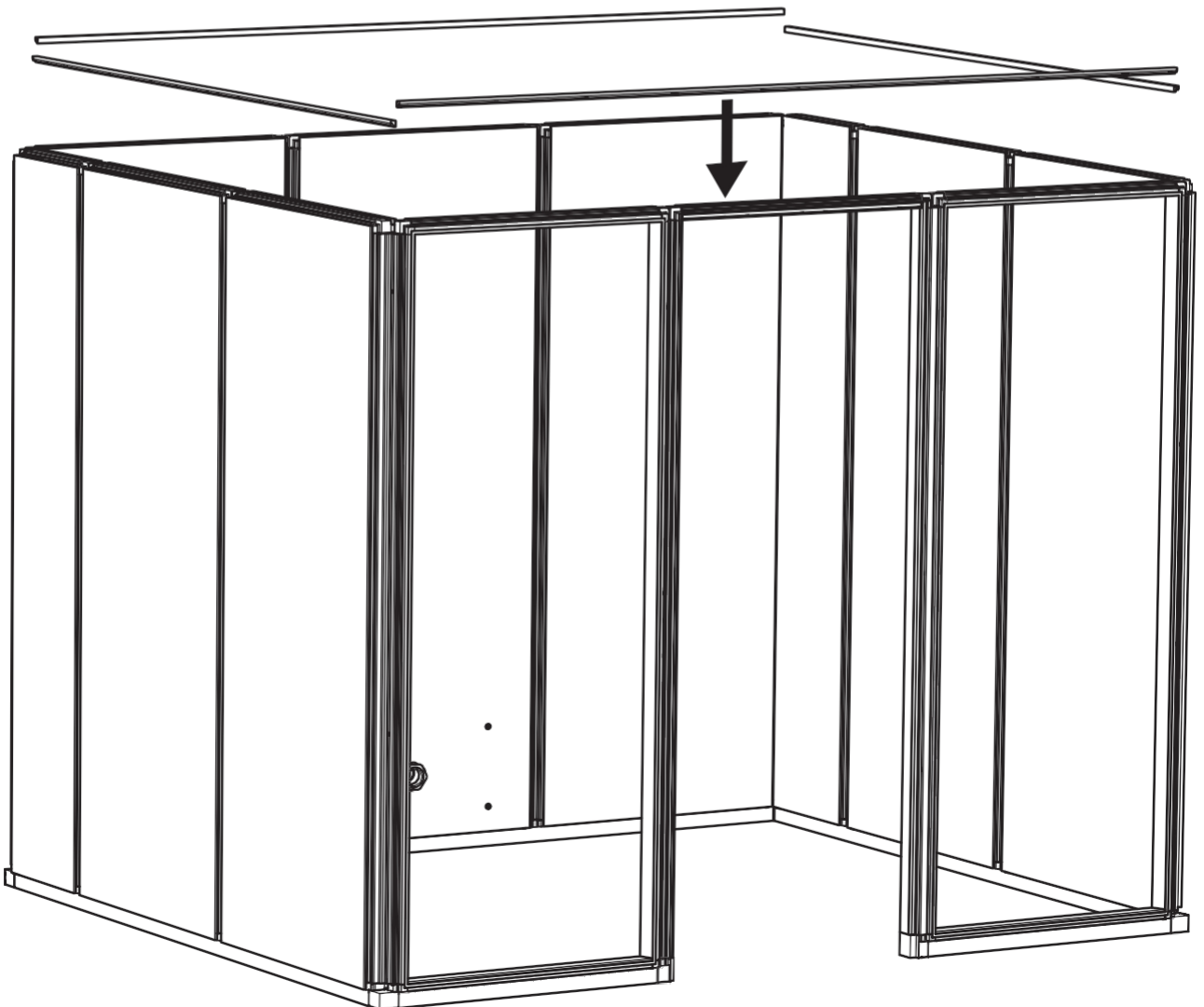

Striscia  
 Piastra di  
 bloccaggio  
 Sicherungsscheibe  
 Rondelle de blocage  
 Направление Плитка  
 blokujaća

x20

33x21x3mm

Intersida  
 Inside  
 Innenseite  
 Intérieur  
 Внутр.  
 Wewnałrz

Utsida  
 Outside  
 Außenseite  
 Extérieur  
 Наруж.  
 Na zewnałrz

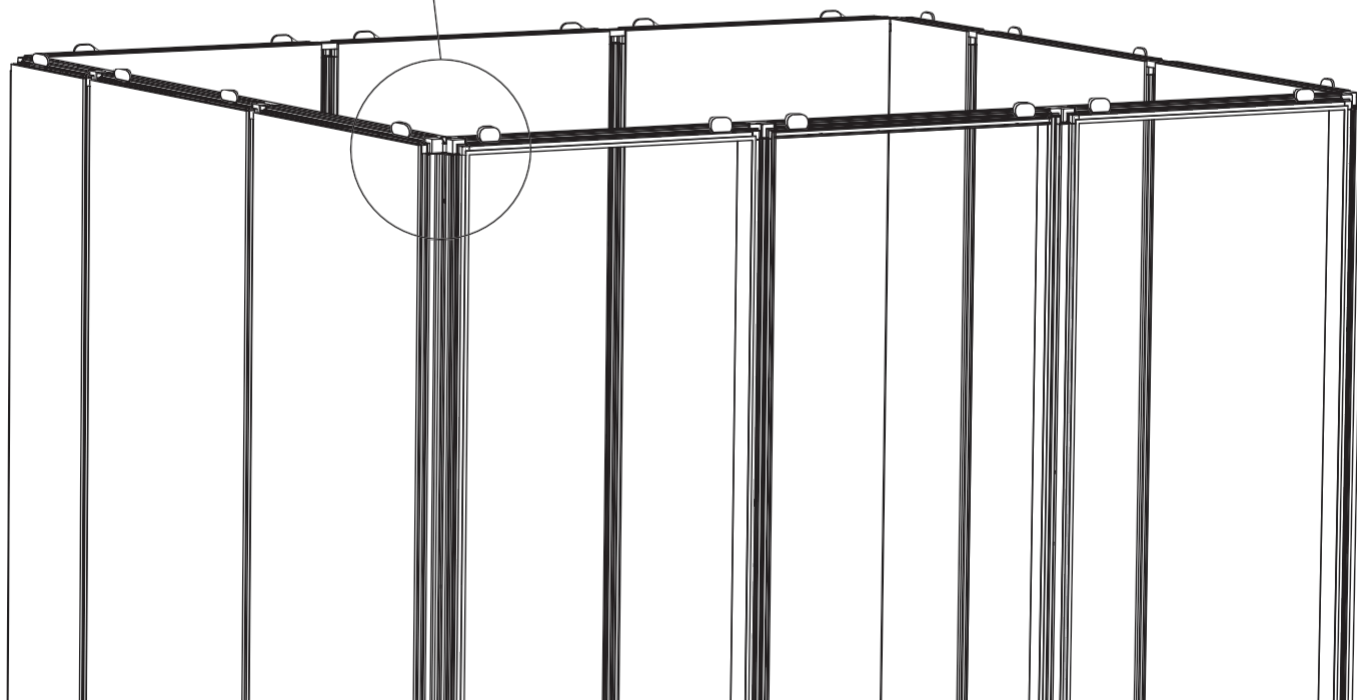
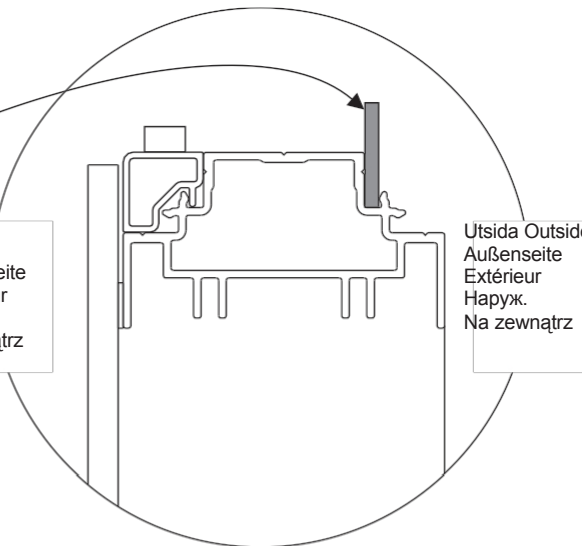
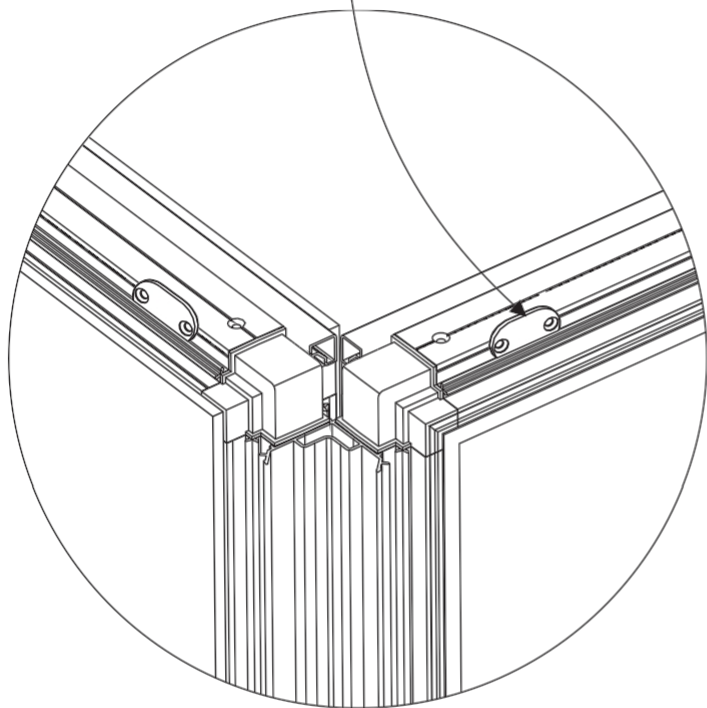

36

Plafond a soffitto  
Потолок  
Sufit 849,5x2099mm

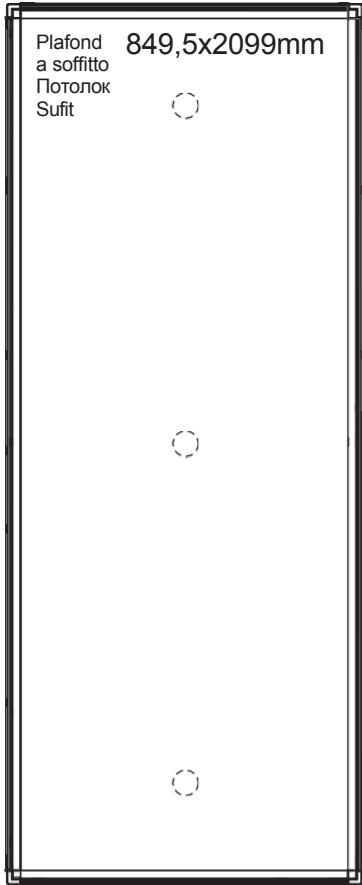

800x2099mm

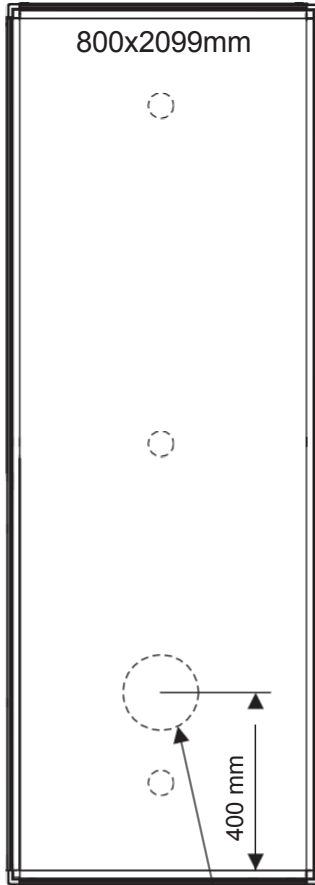

849,5x2099 mm

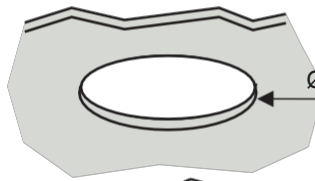
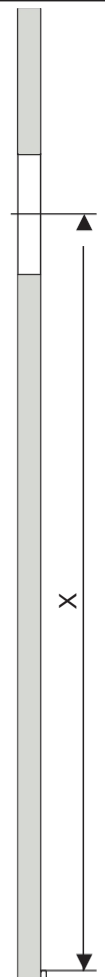
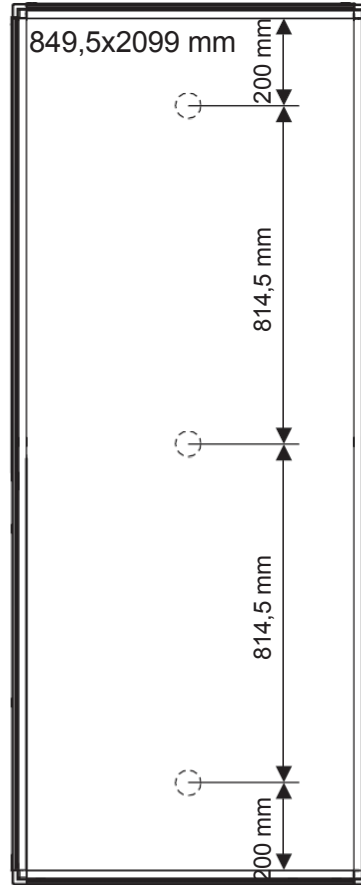

Ø32 mm



OBS! La posizione dello sfiato è importante.  
NB: La posizione dello sfiato in uscita è importante.

Suggerimenti: La posizione dell'apertura è importante.

NOTA : Prestare attenzione alla scelta della posizione della bocca di uscita dell'aria.

Внимание! Установка выпускного клапана очень важна.

UWAGA! La collezione di mobili da giardino è stata realizzata in modo da garantire un'ottima qualità di vita.

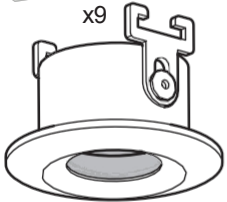
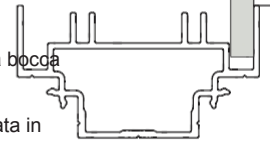

x9



Ø142mm

Ø8mm

x2



x2

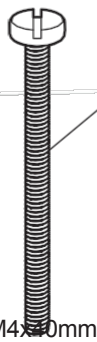

M4x40mm

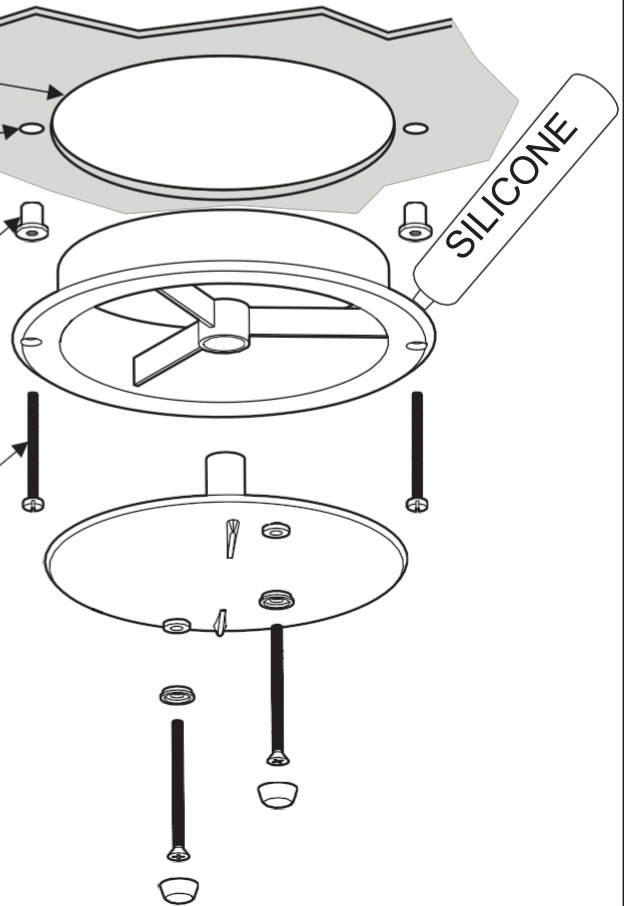

Utluftsventil  
Bocchetta di uscita  
Abluftventil  
Sortie d'air  
Вывод воздуха  
Articoli da regalo

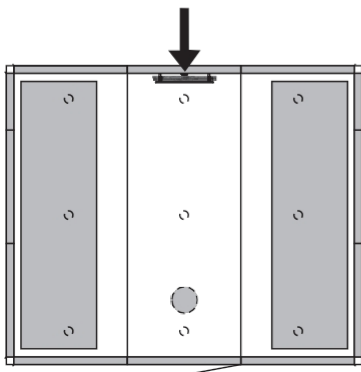

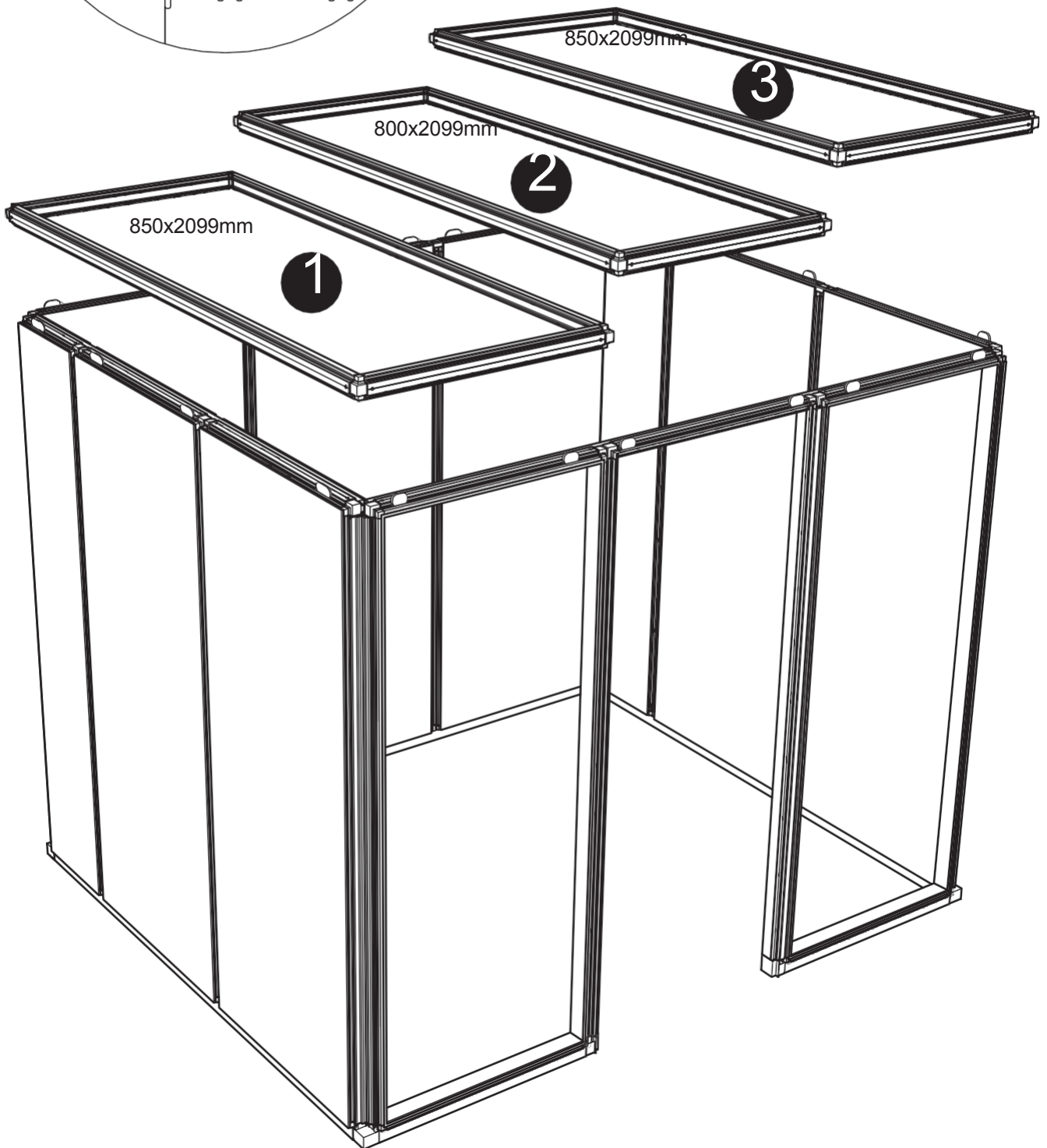
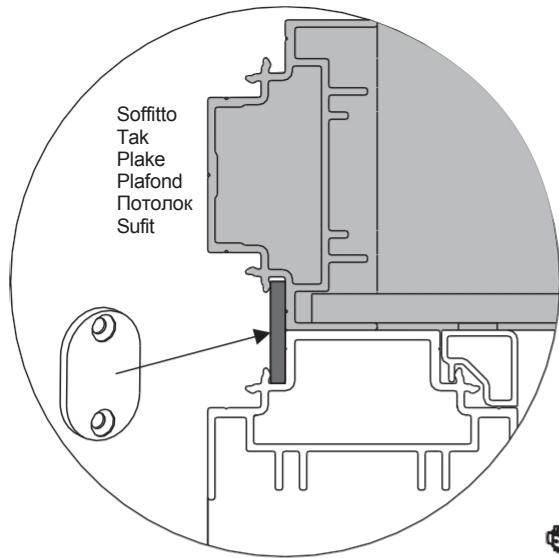

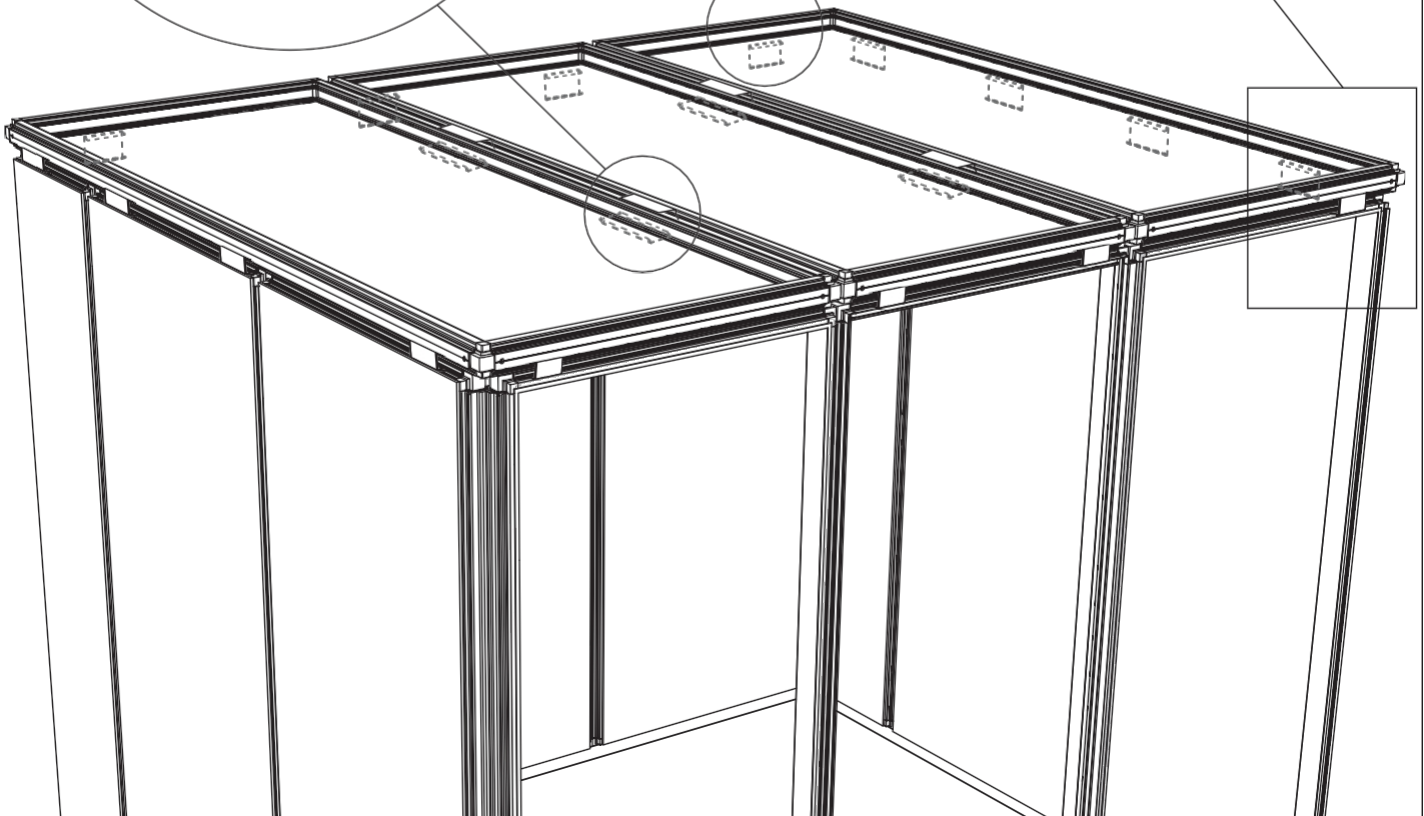
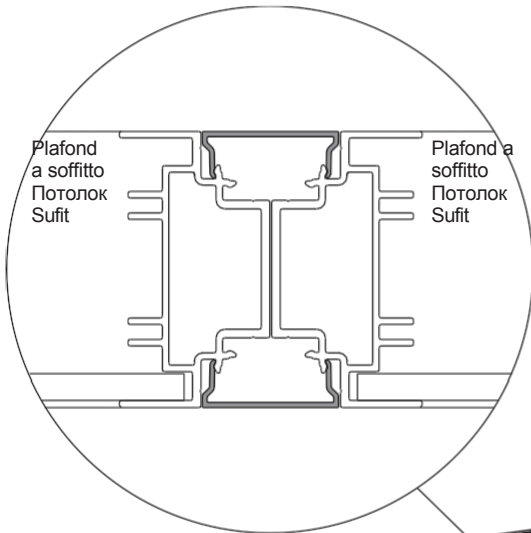
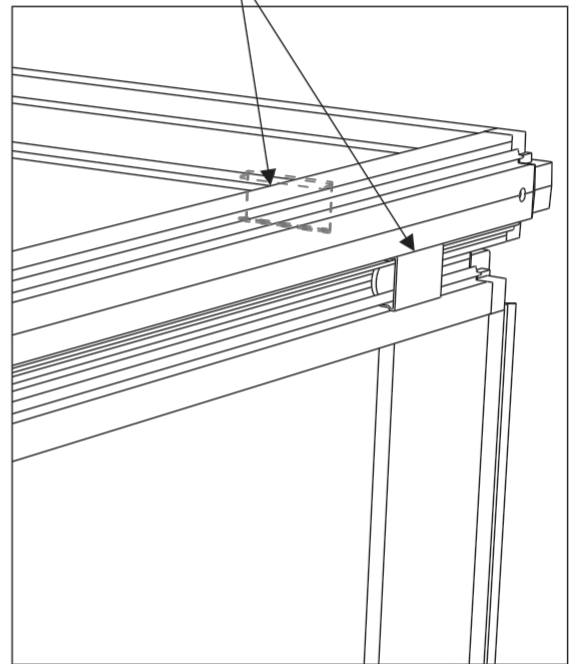
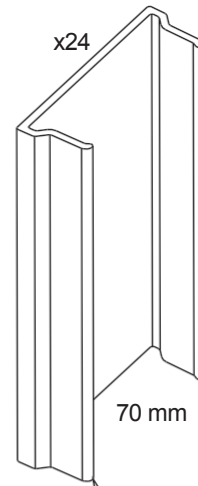
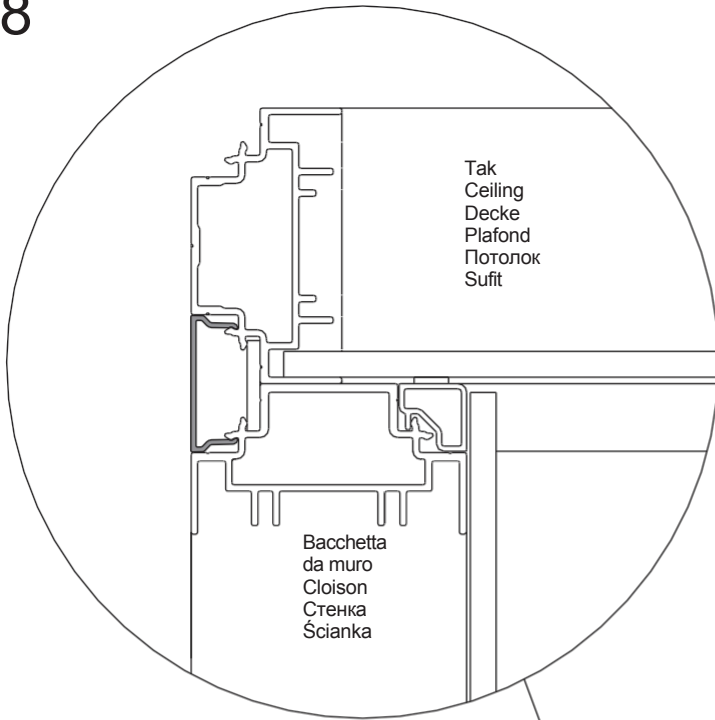

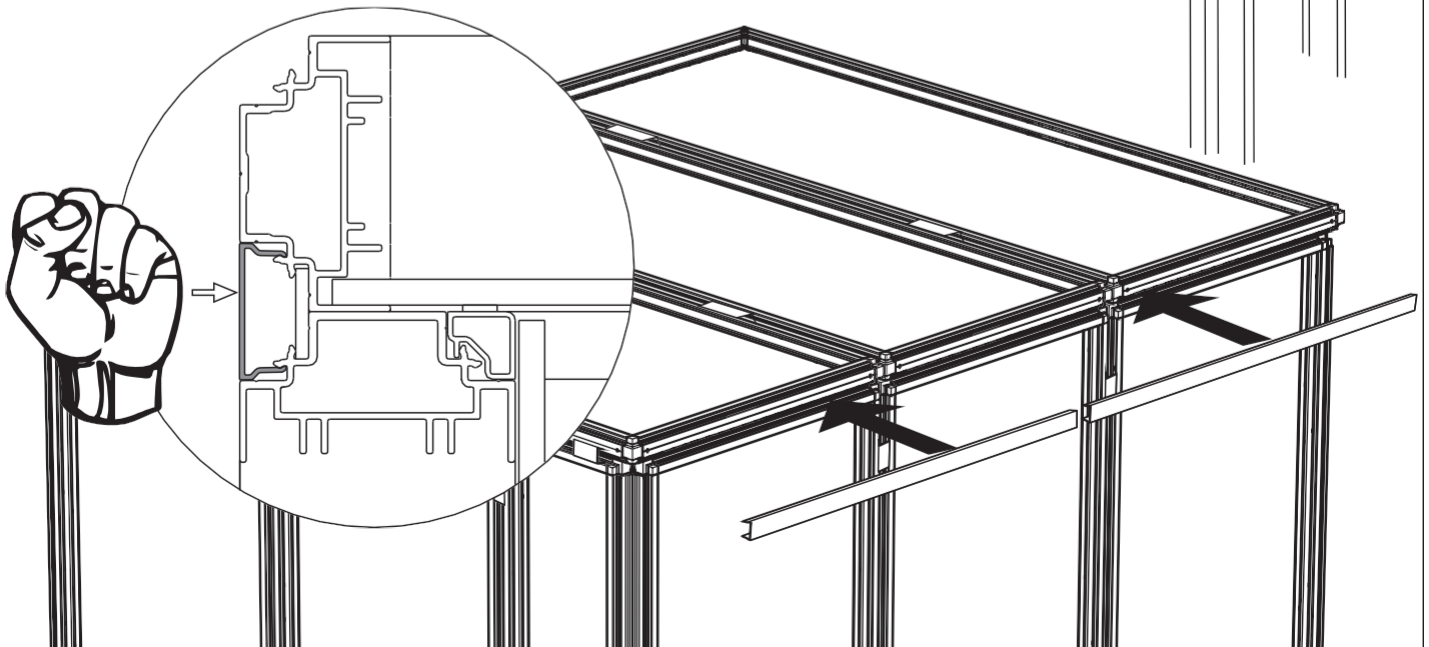
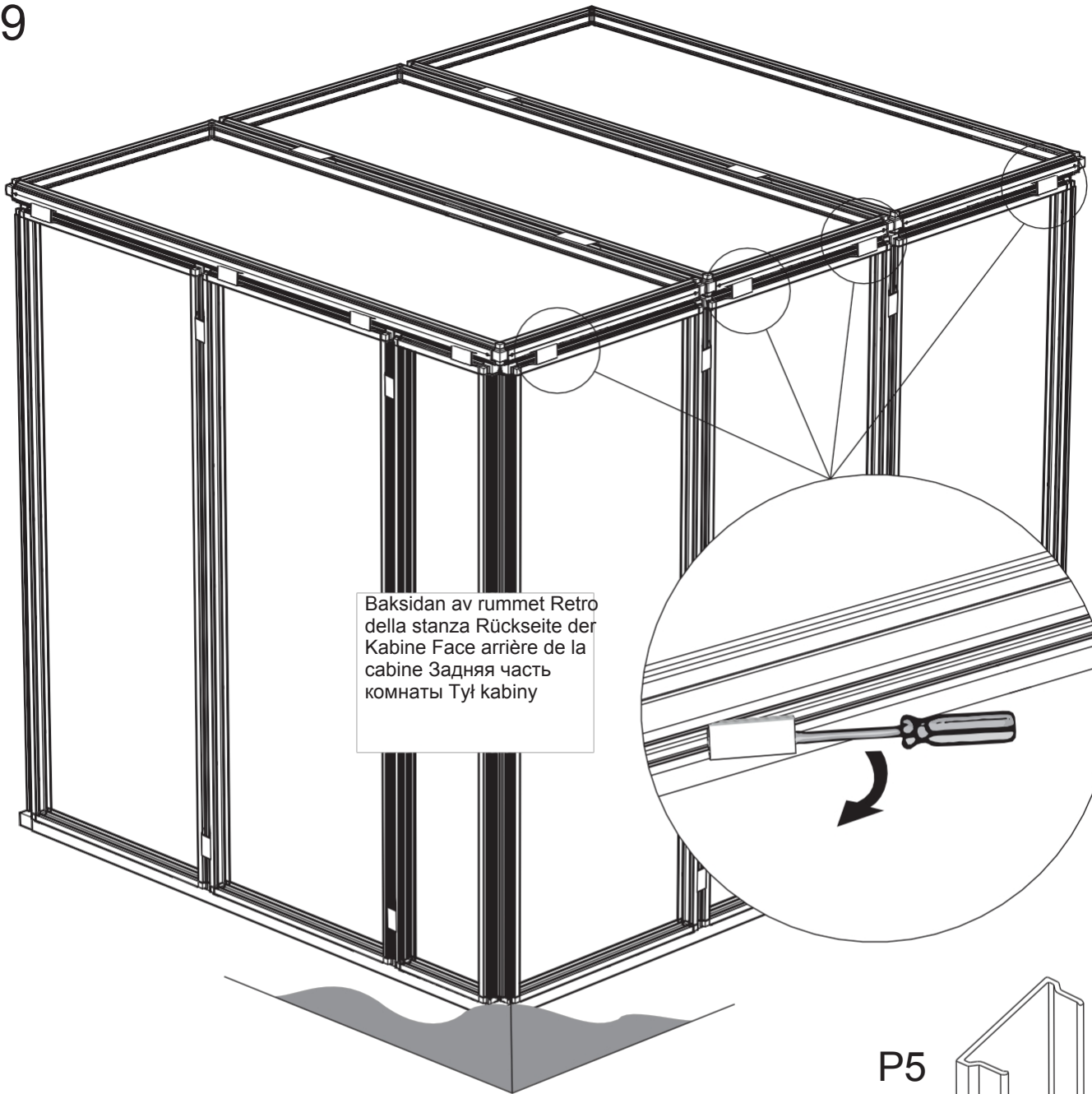

40

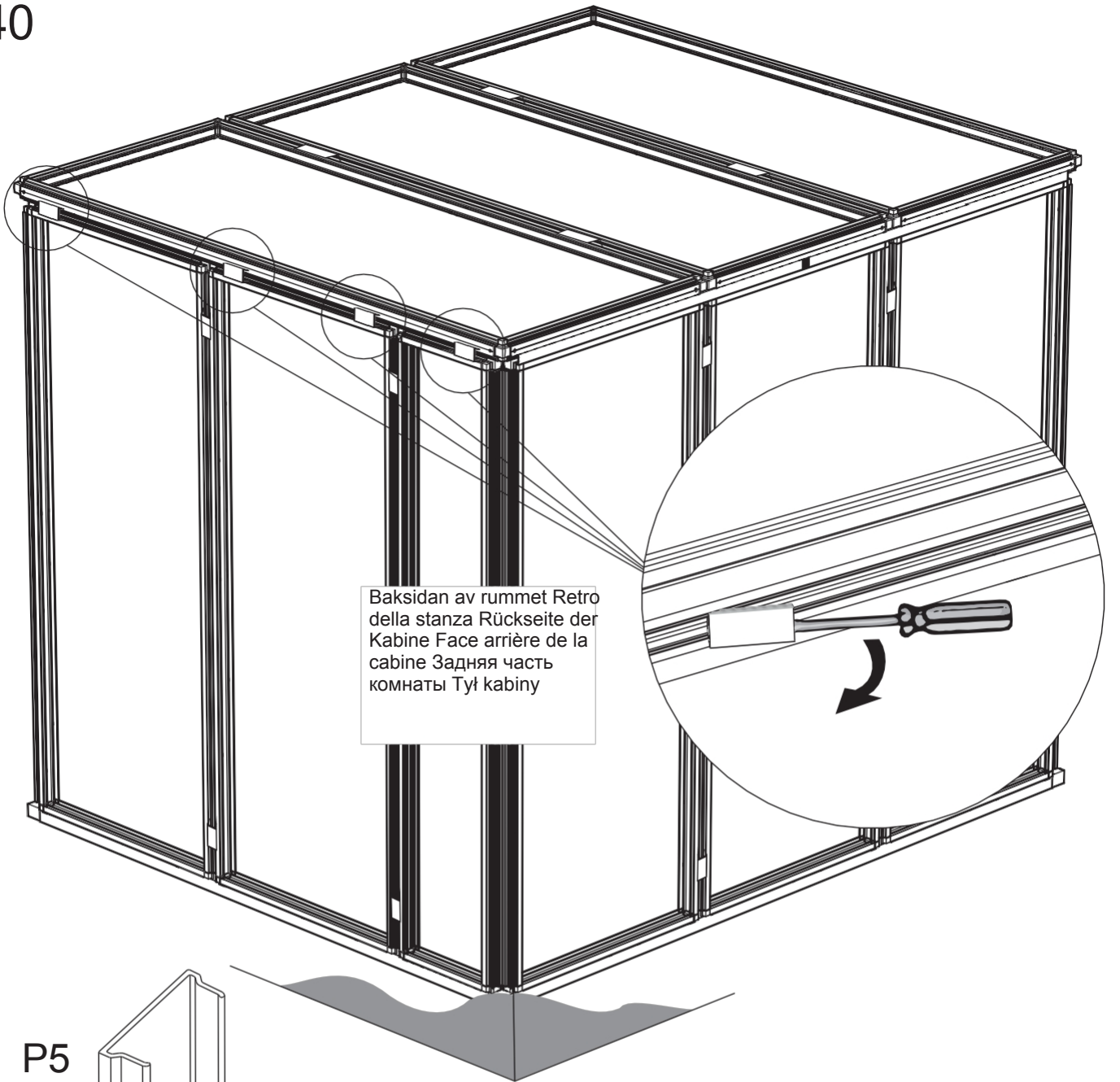

P5  
1968 mm

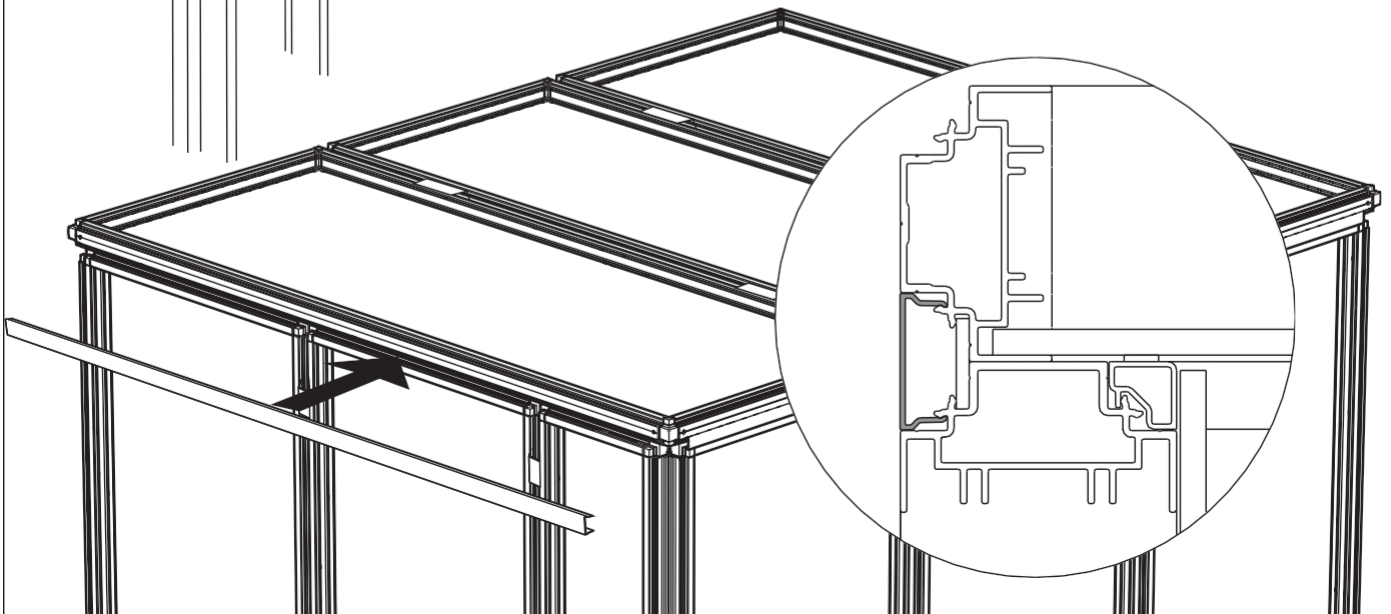
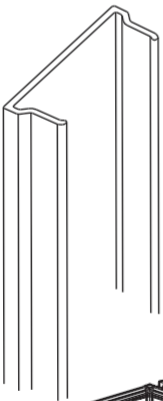

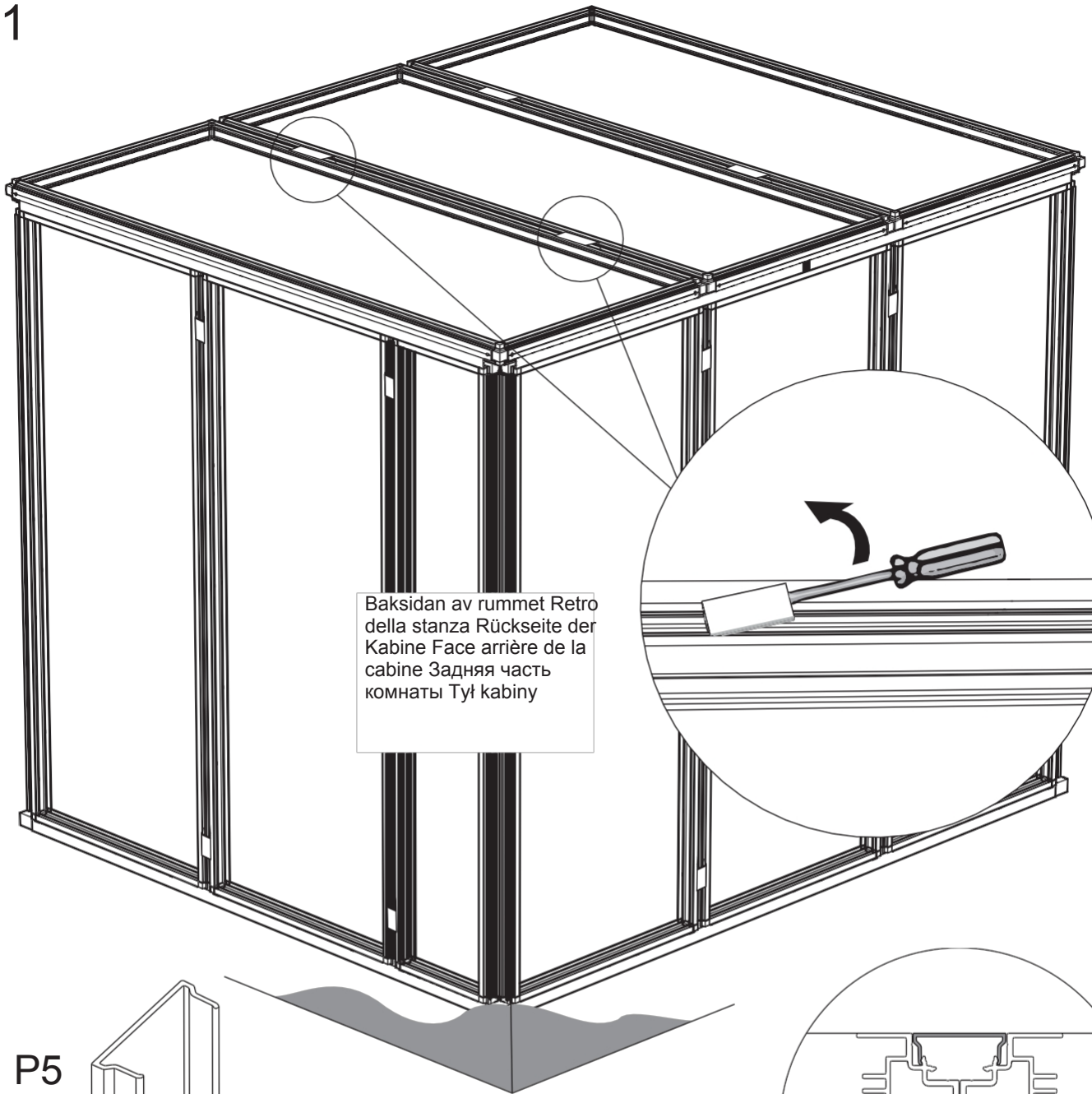

P5  
1968 mm

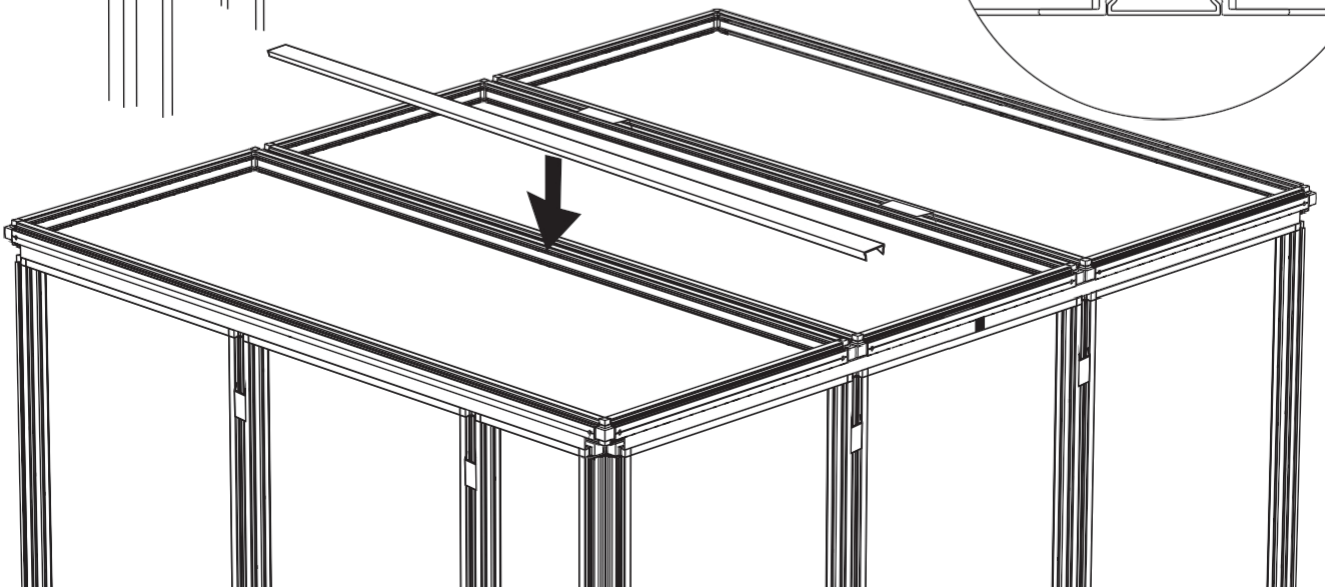
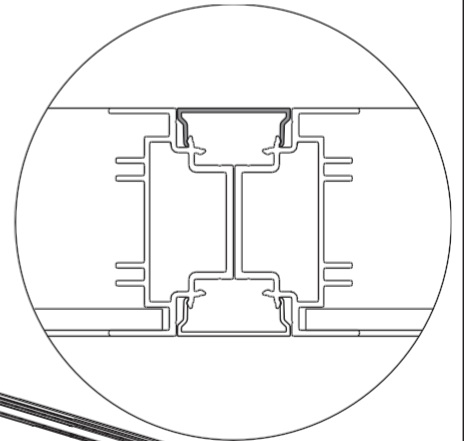
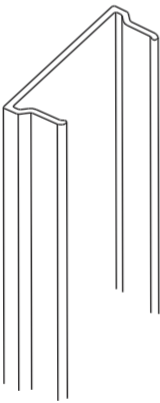

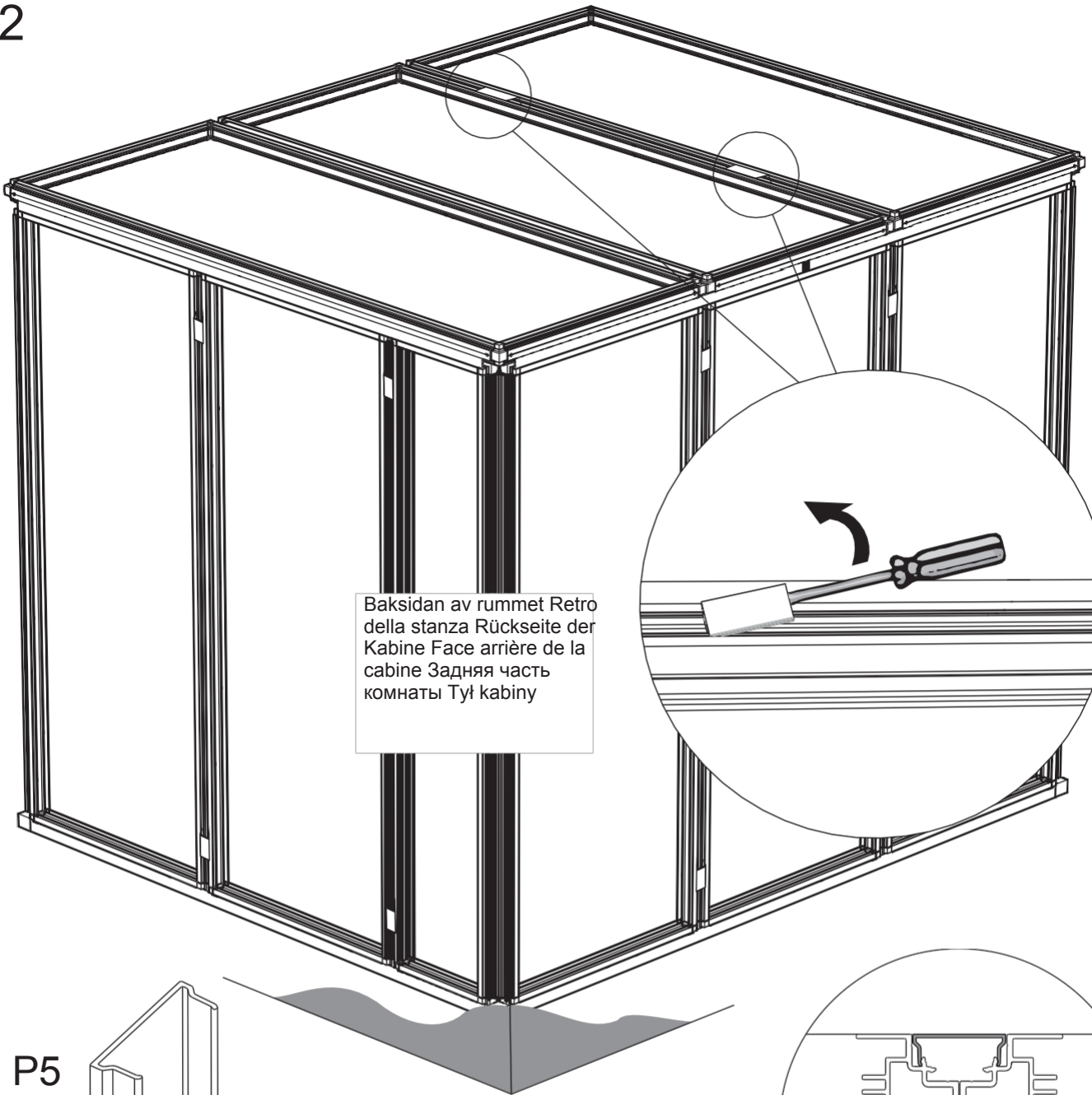

Baksidan av rummet Retro  
della stanza Rückseite der  
Kabine Face arrière de la  
cabine Задняя часть  
комнаты Тул kabiny

P5  
1968 mm

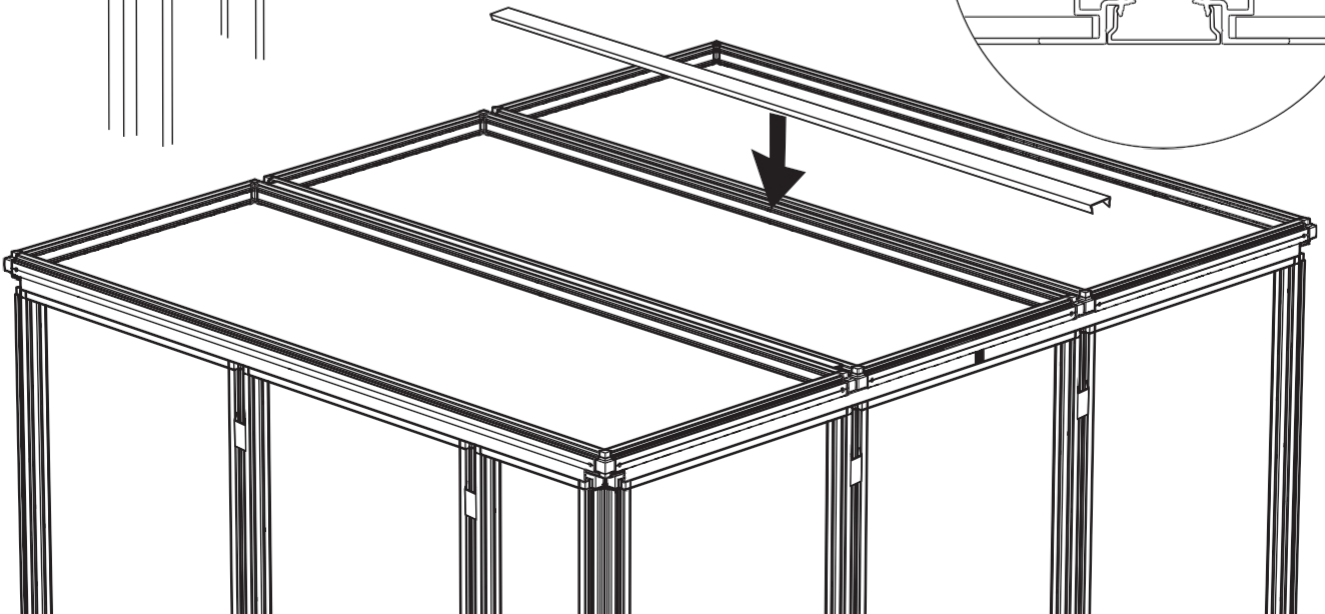
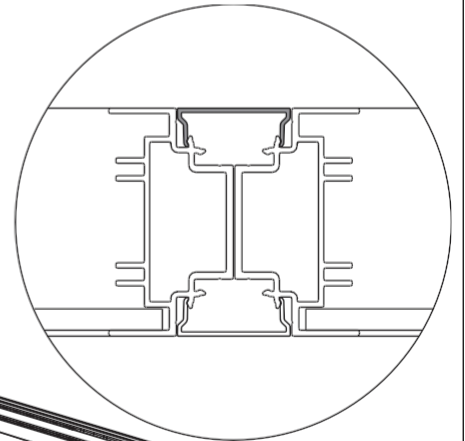
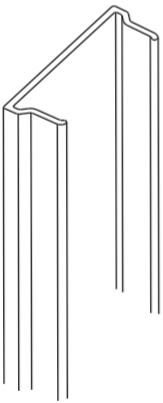

43

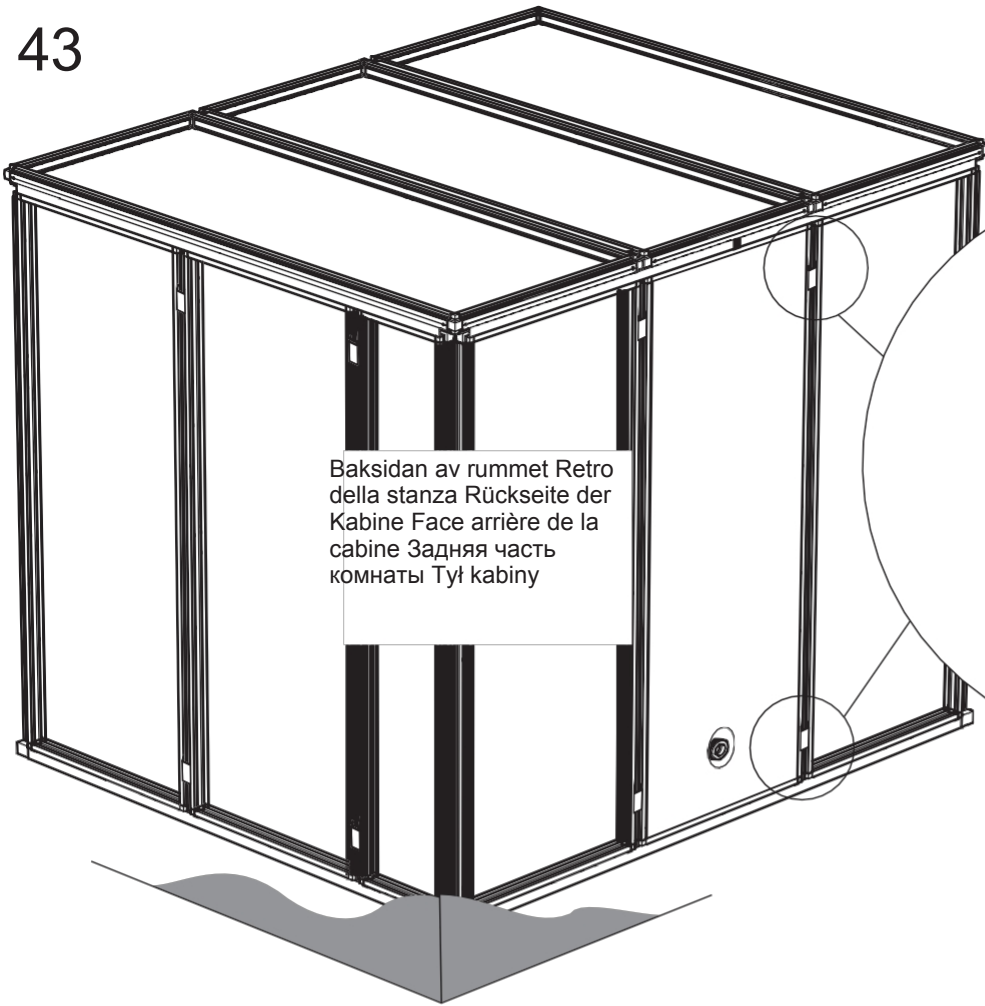

Baksidan av rummet Retro  
della stanza Rückseite der  
Kabine Face arrière de la  
cabine Задняя часть  
комнаты Туł kabiny

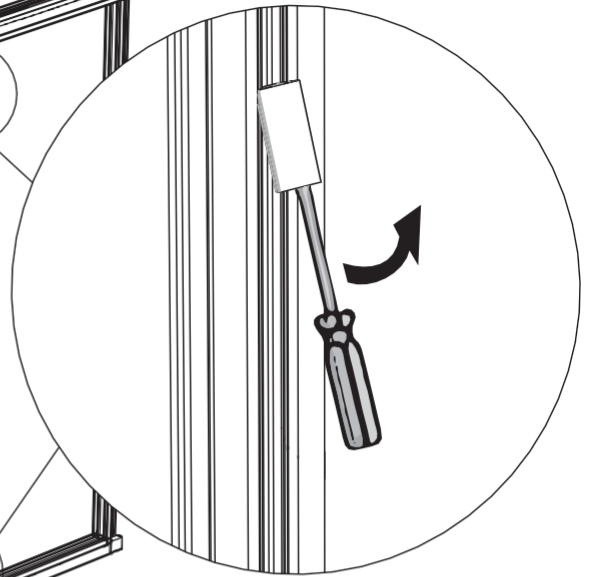

P5

1968 mm

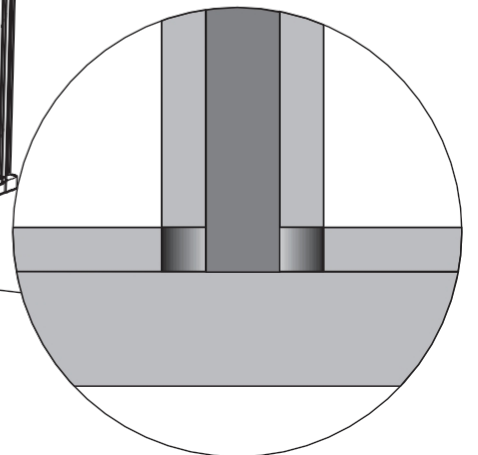
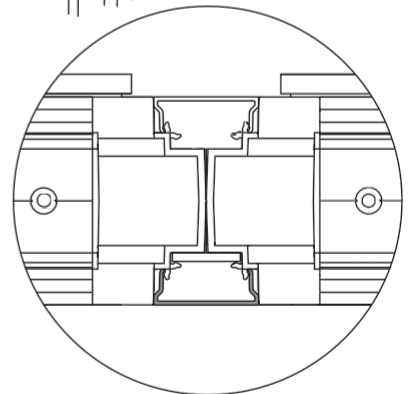
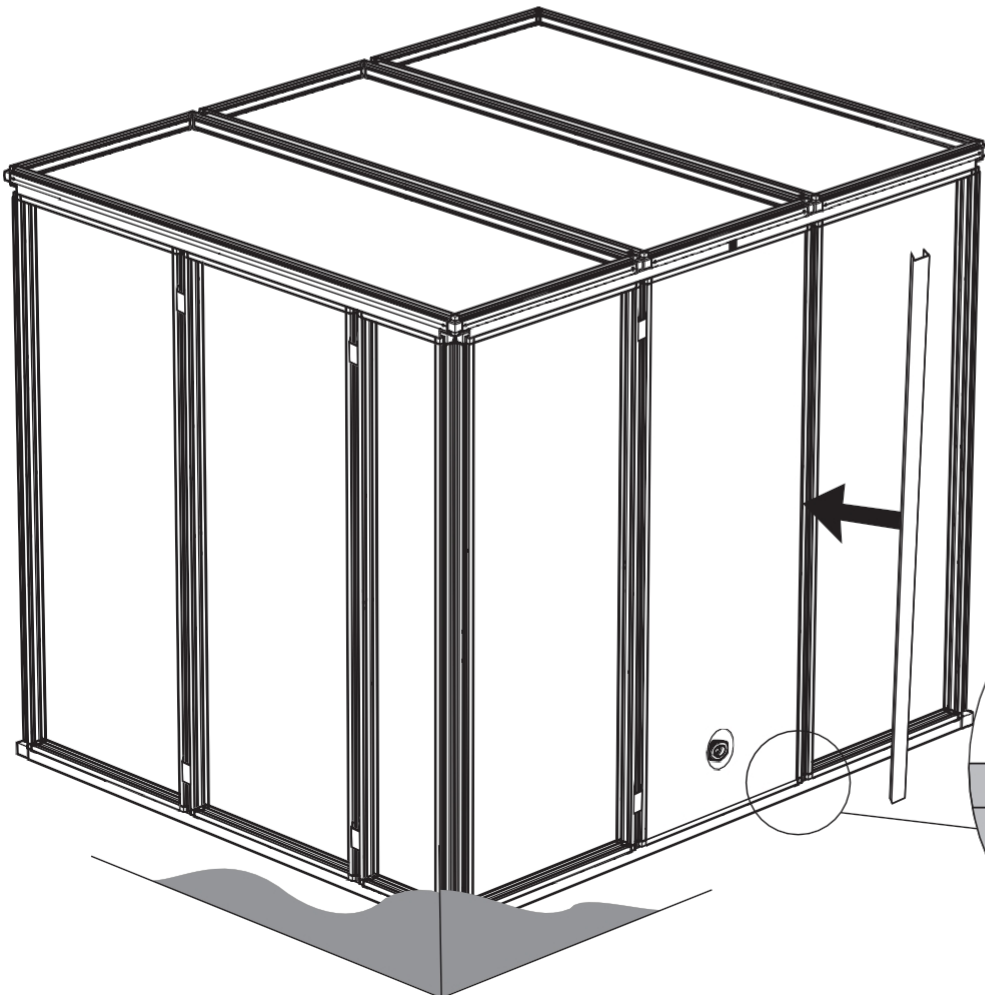
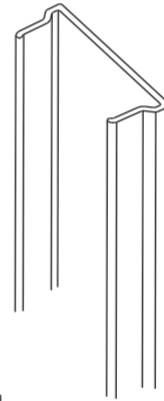

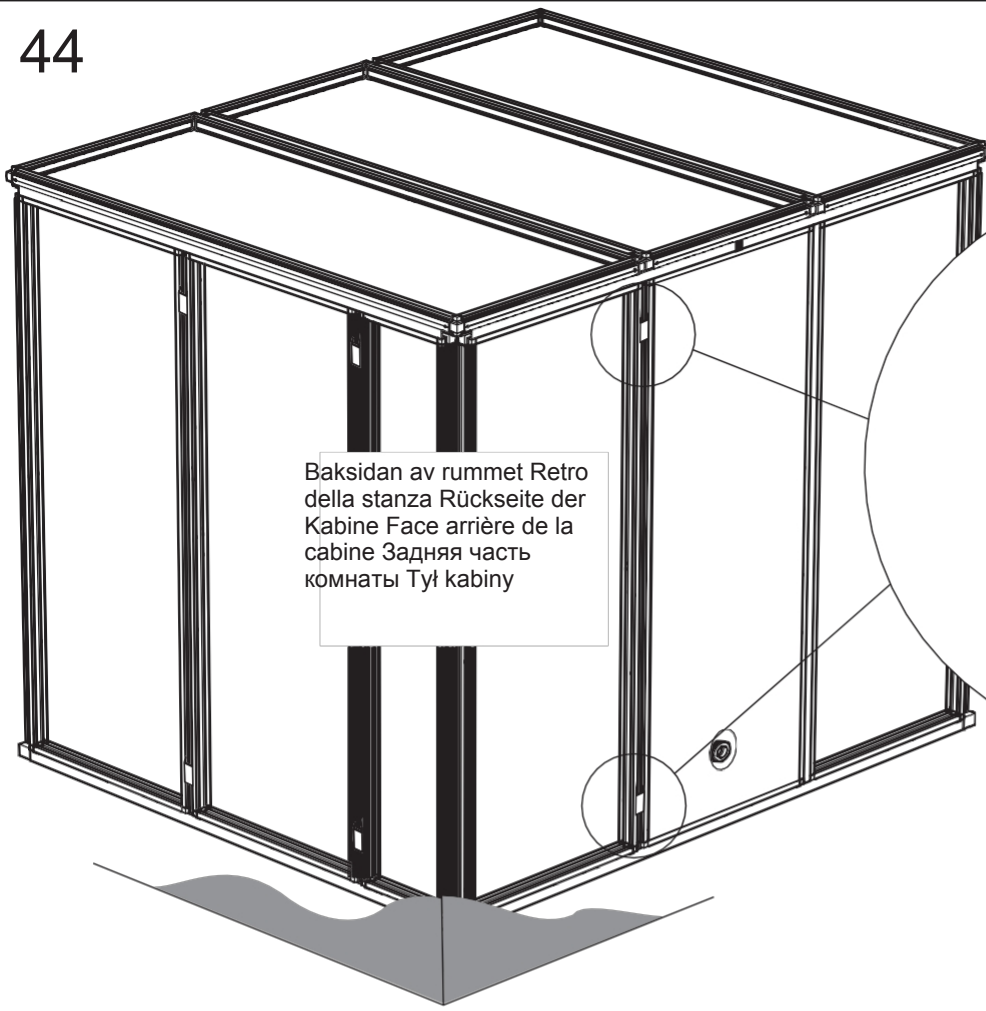

Baksidan av rummet Retro della stanza Rückseite der Kabine Face arrière de la cabine Задняя часть комнаты Тул kabiny

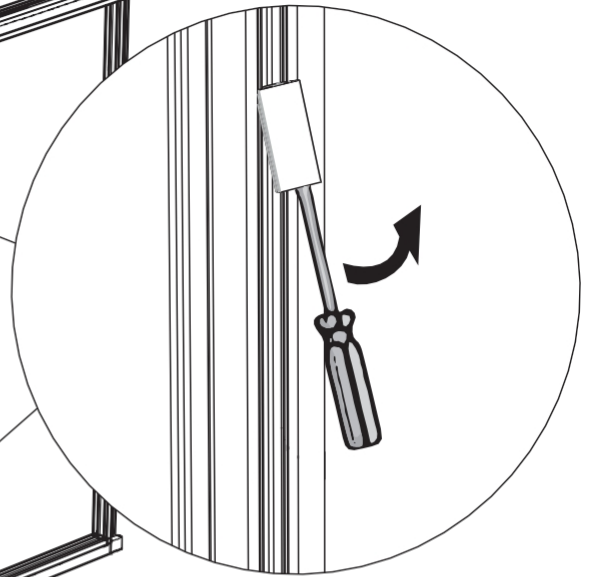

P5

1968mm

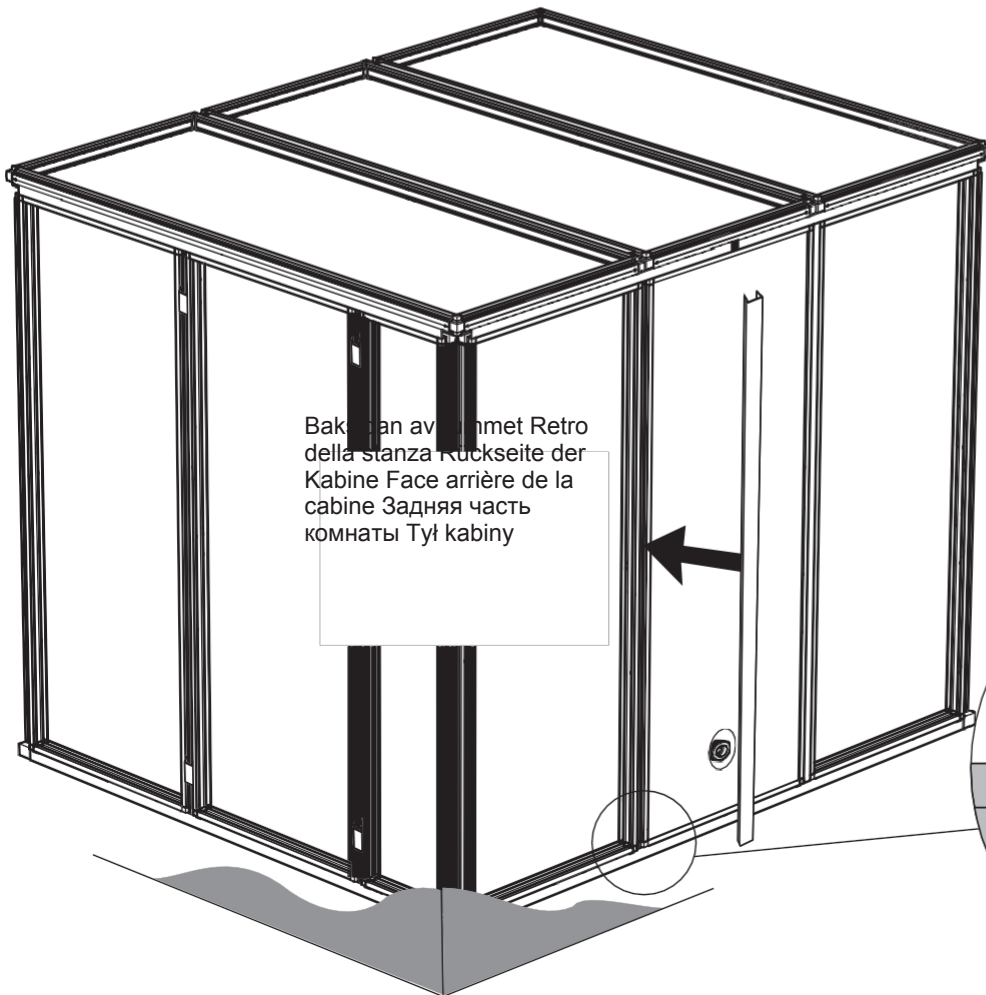
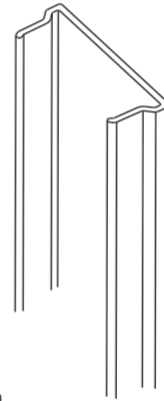

Baksidan av rummet Retro della stanza Rückseite der Kabine Face arrière de la cabine Задняя часть комнаты Тул kabiny

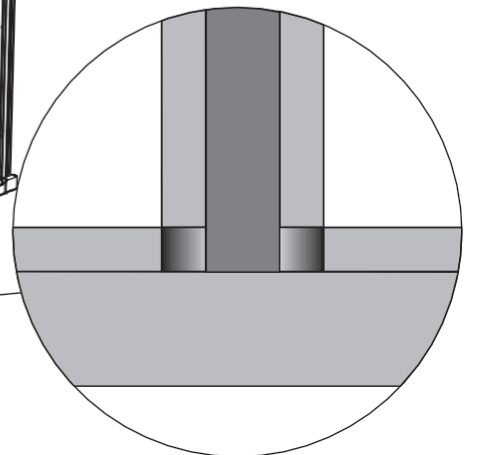
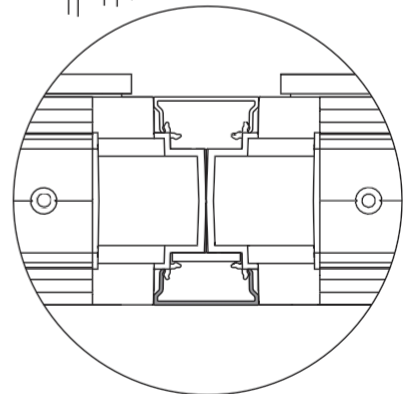

45

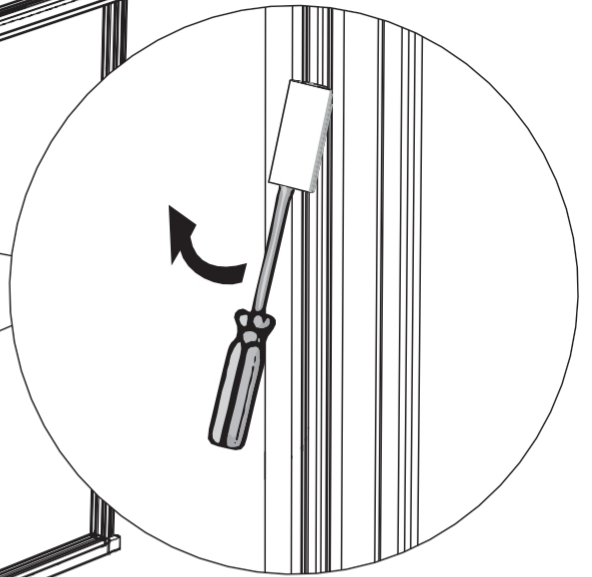
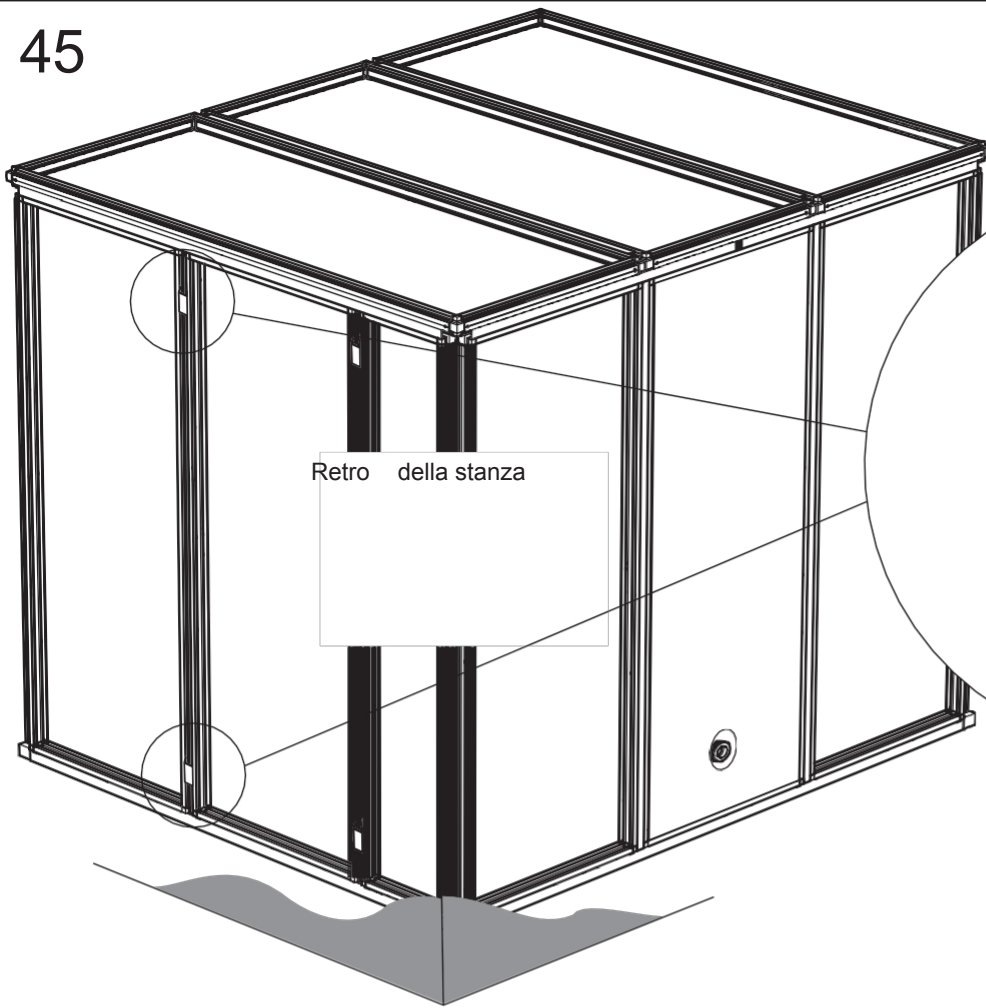

P5

1968mm

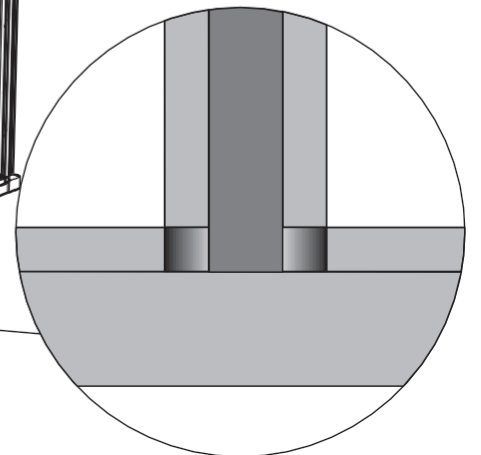
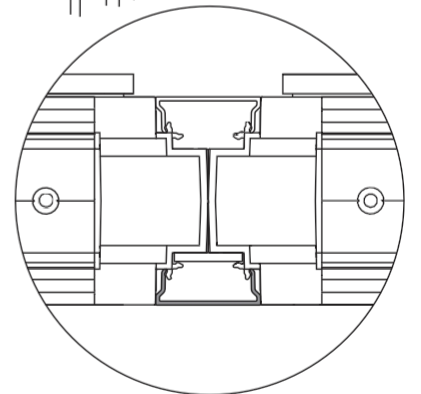
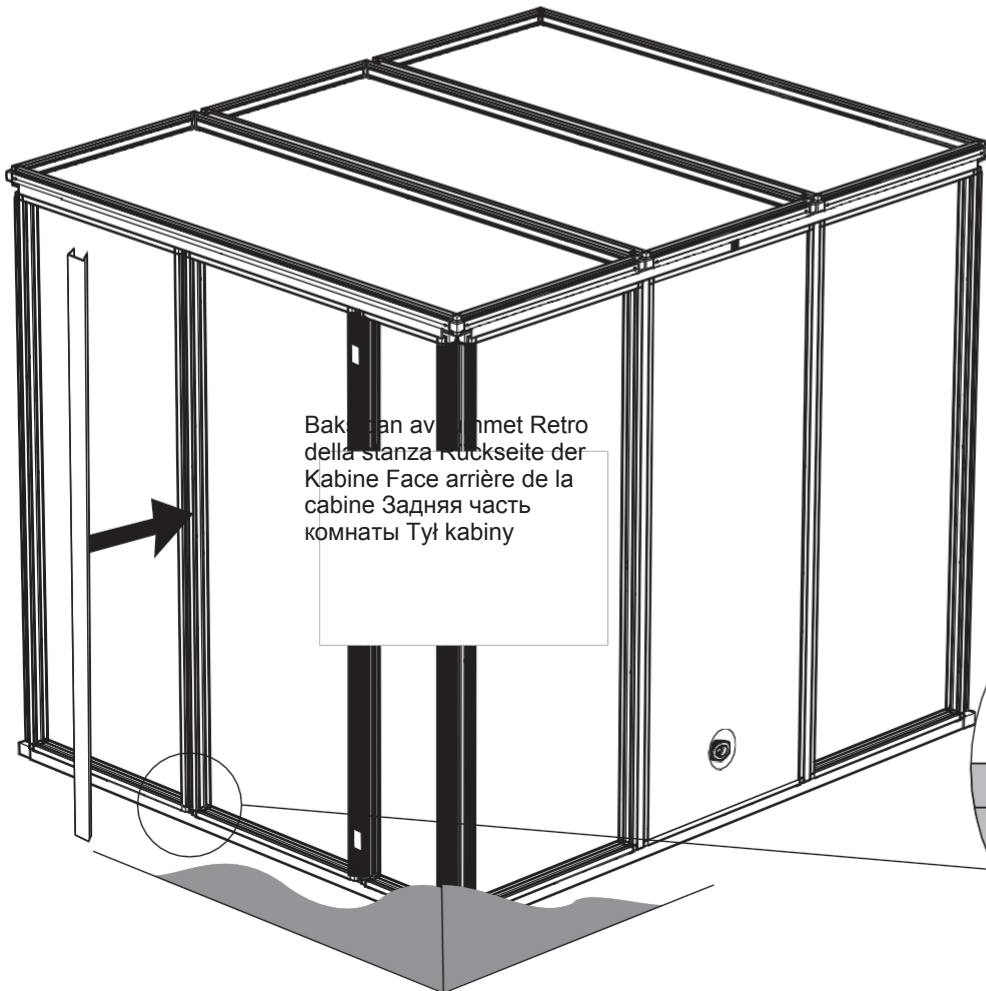
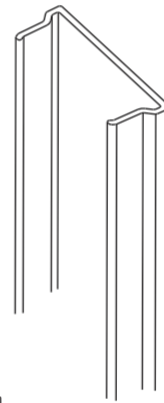

46

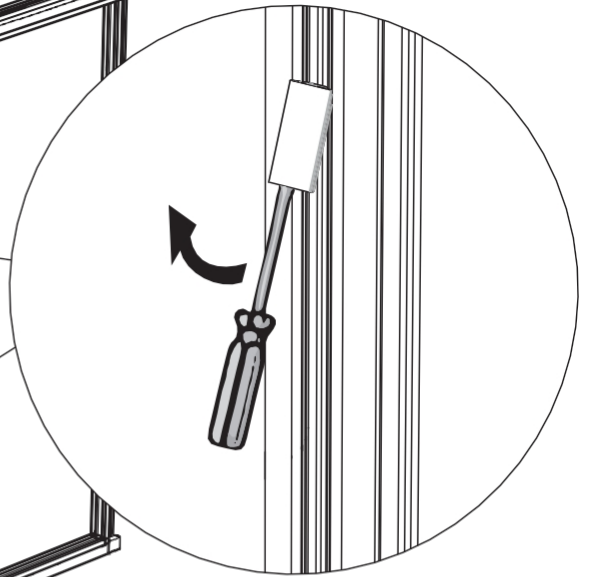
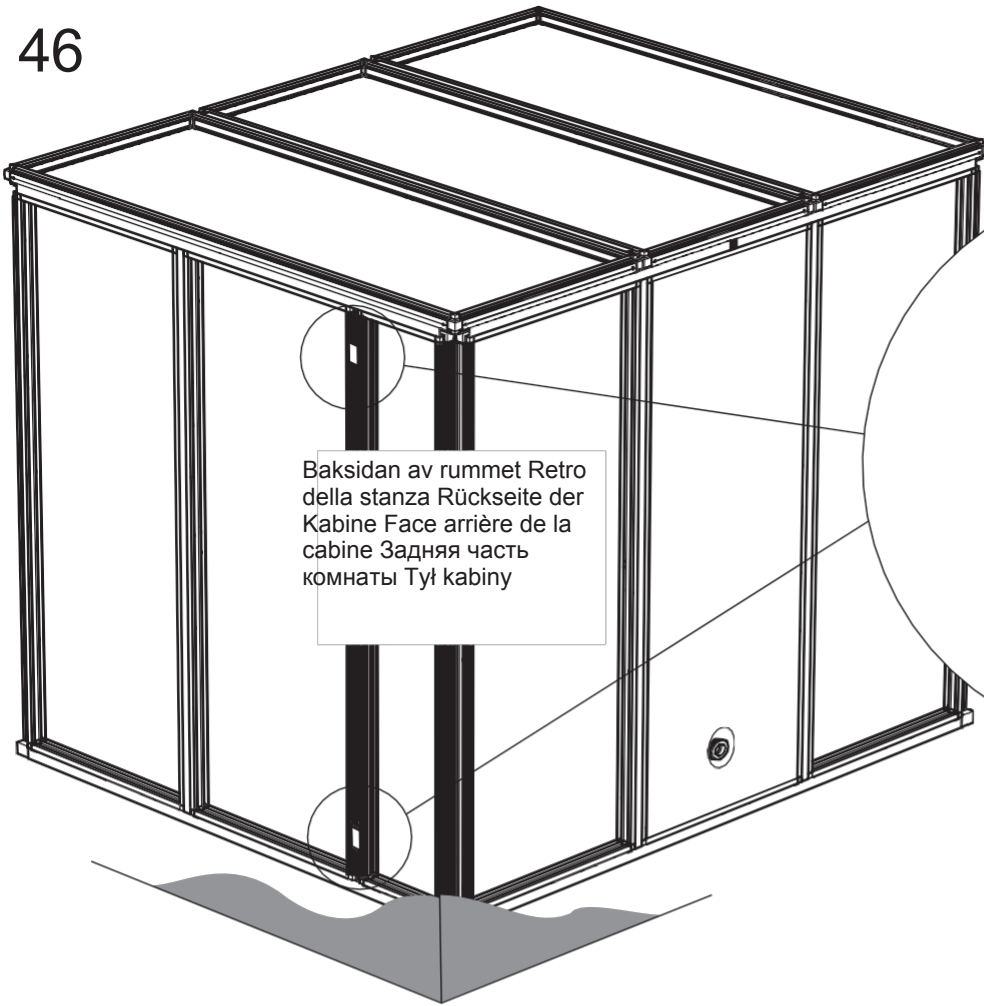

P5

1968 mm

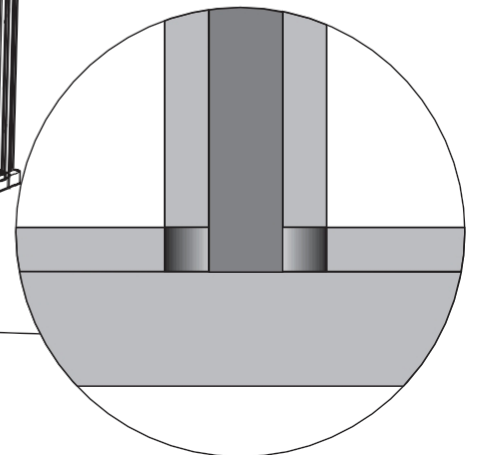
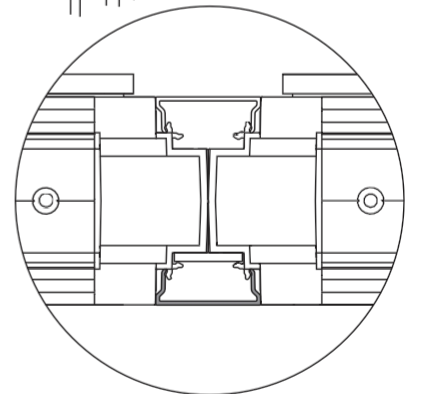
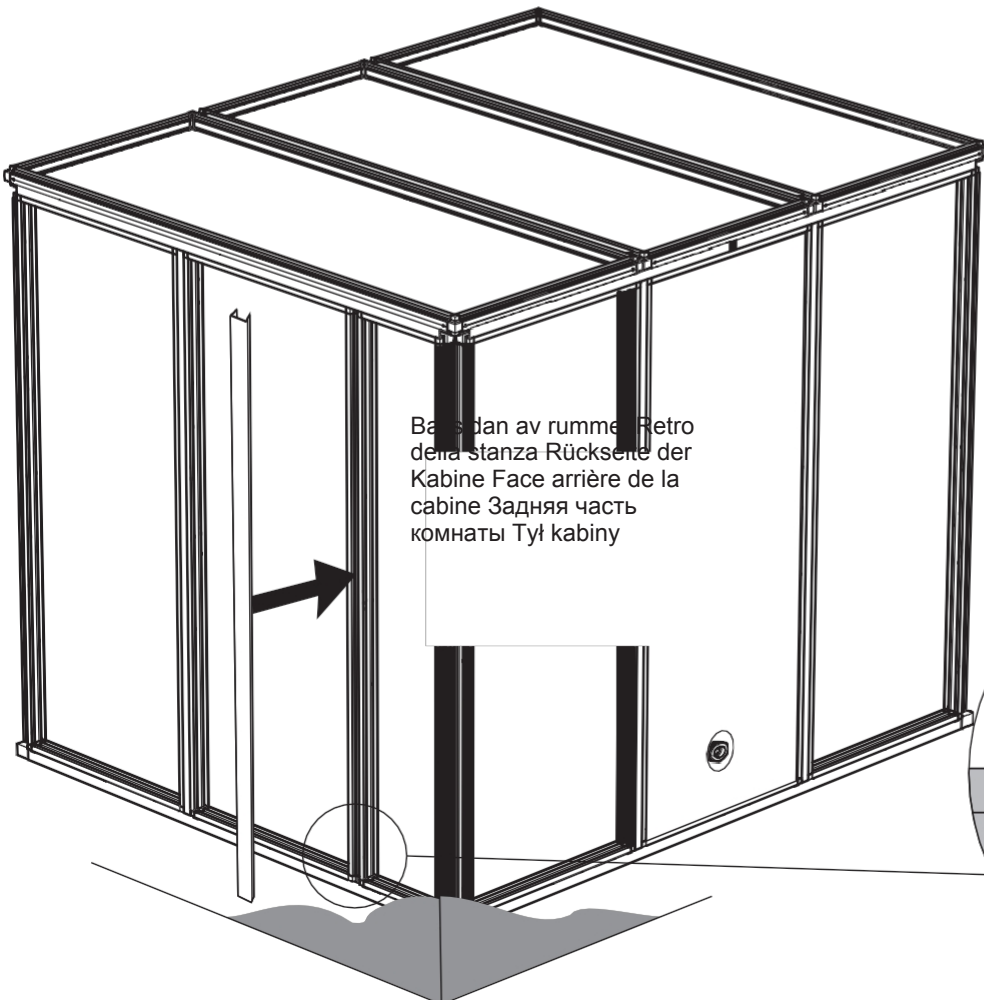
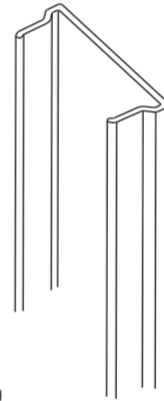

47

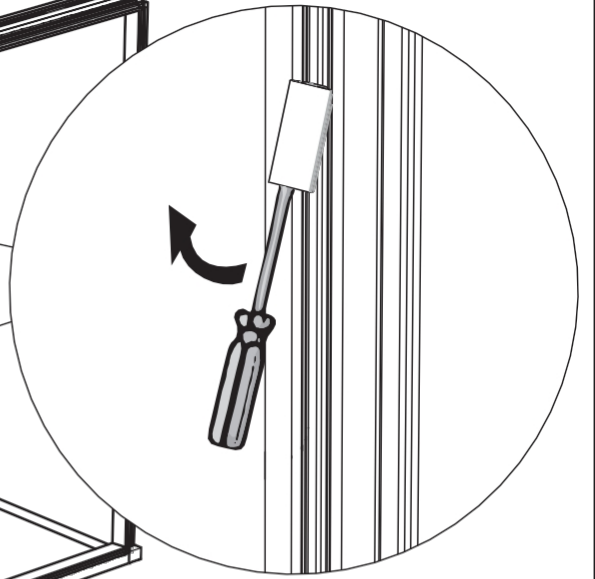
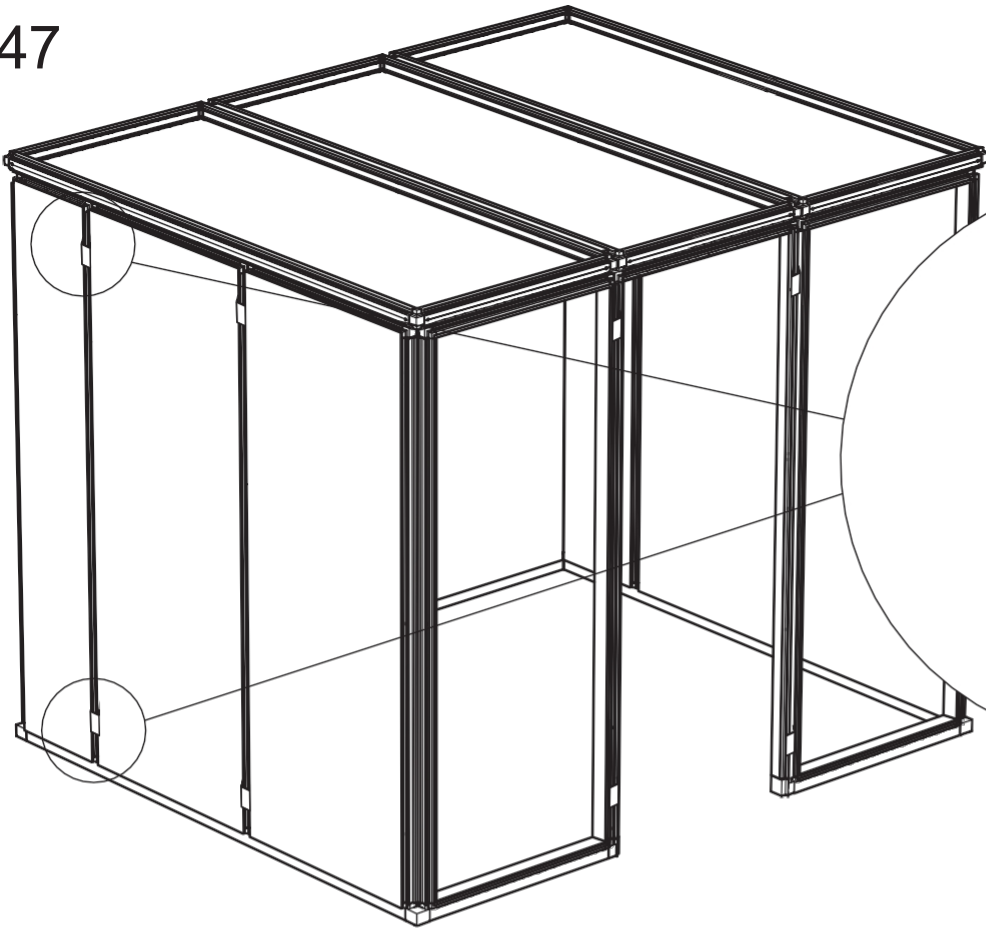

P8



1968mm

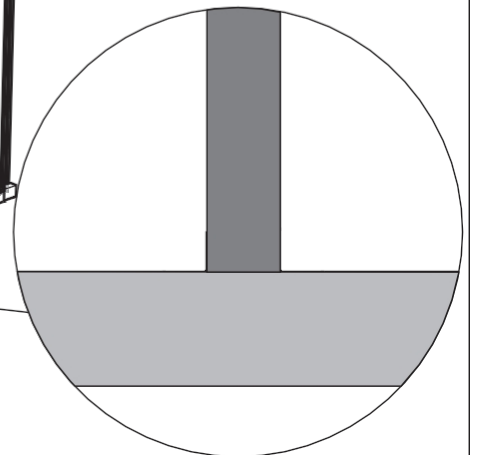
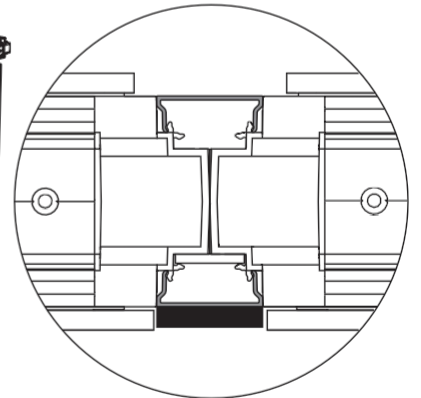
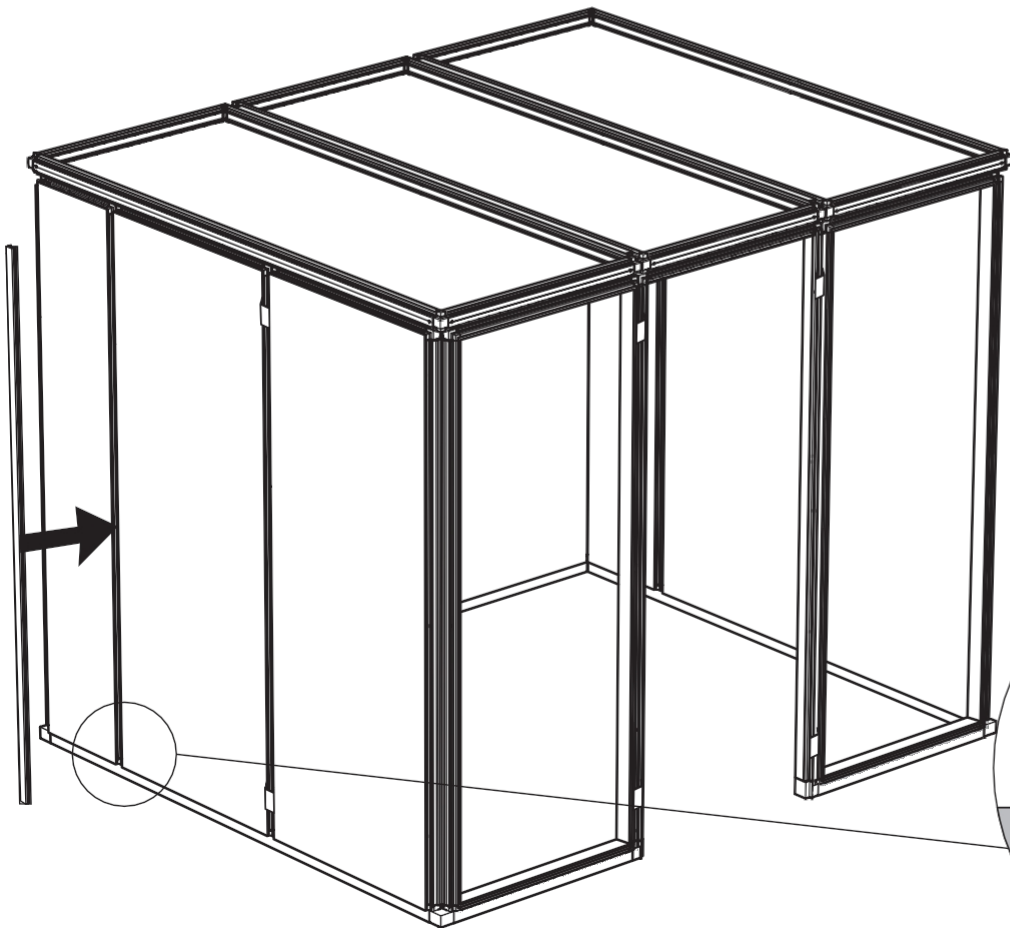

48

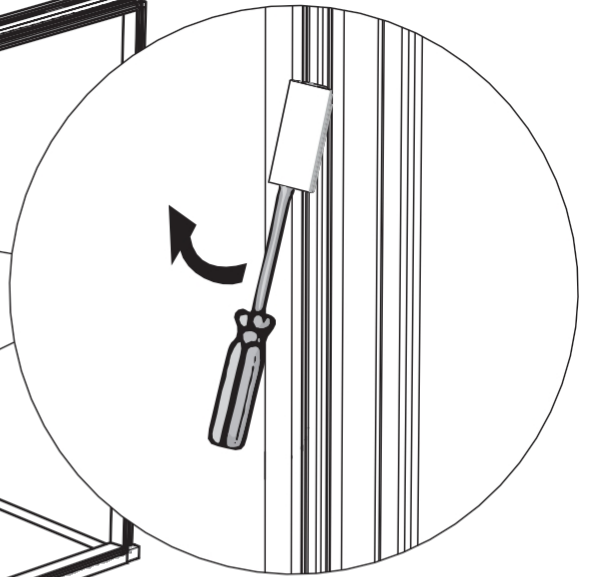
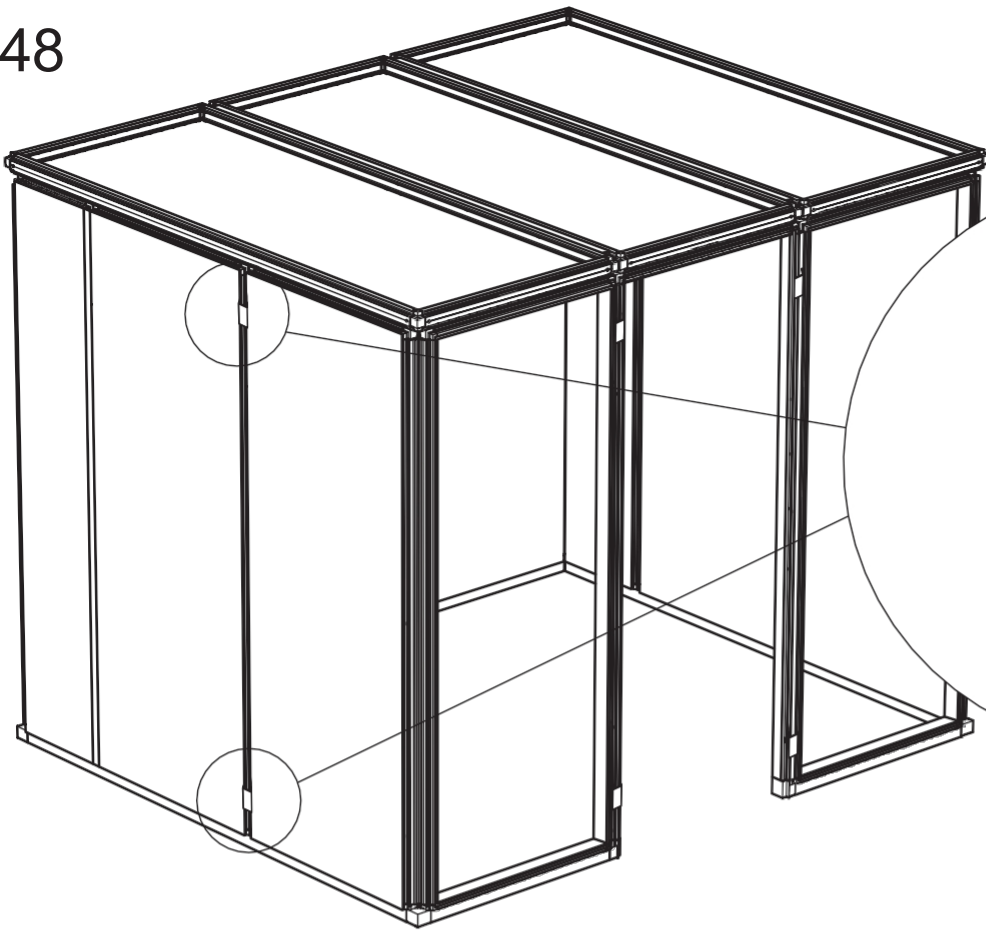

P8



1968 mm

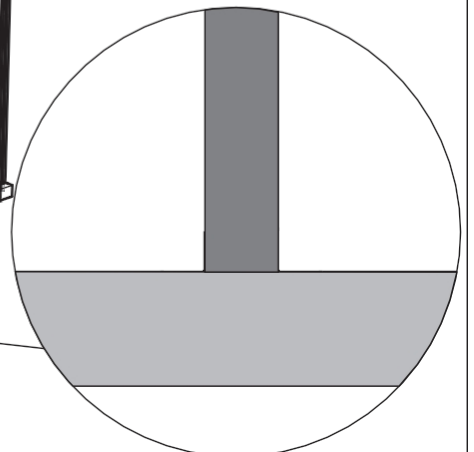
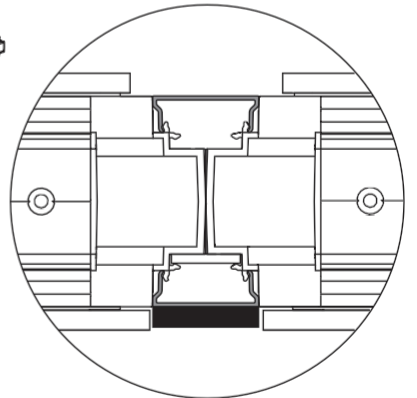
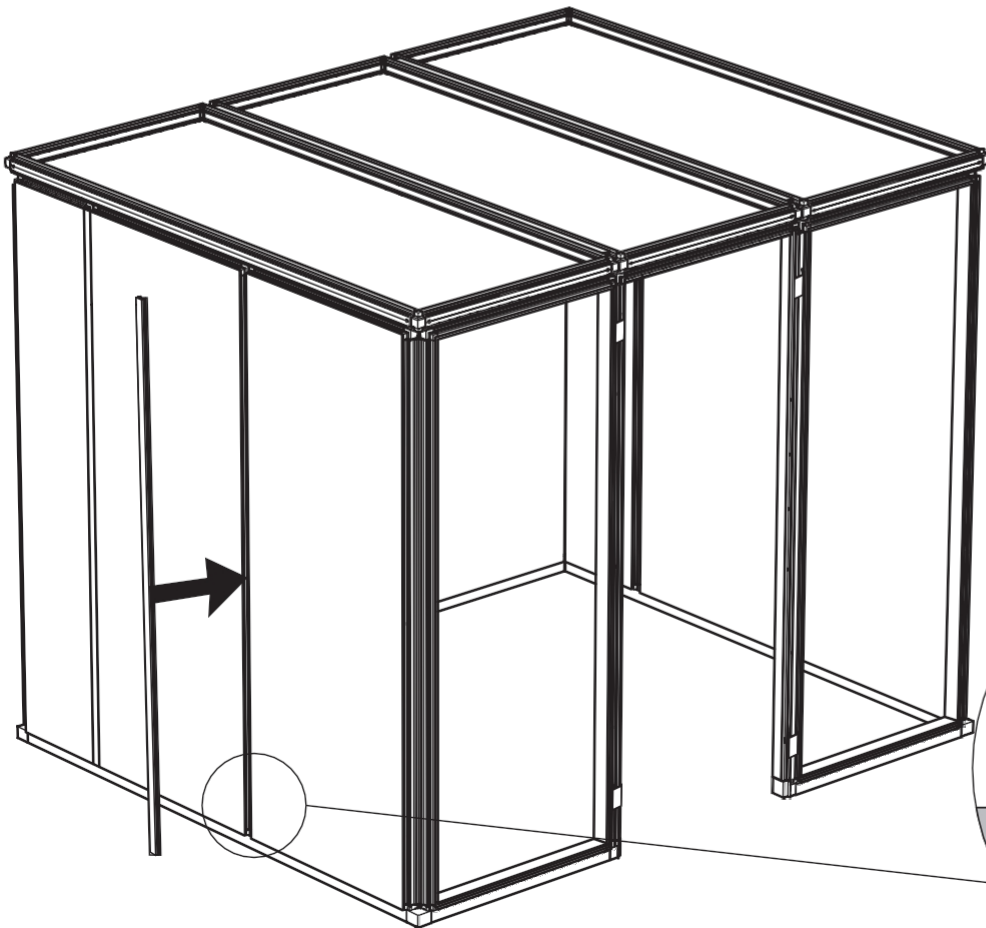

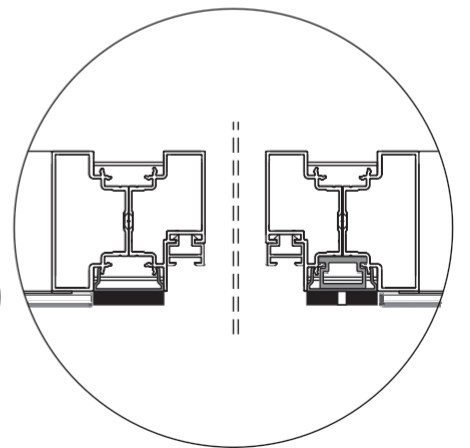
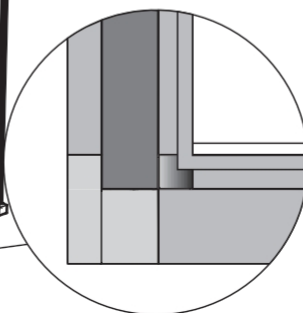
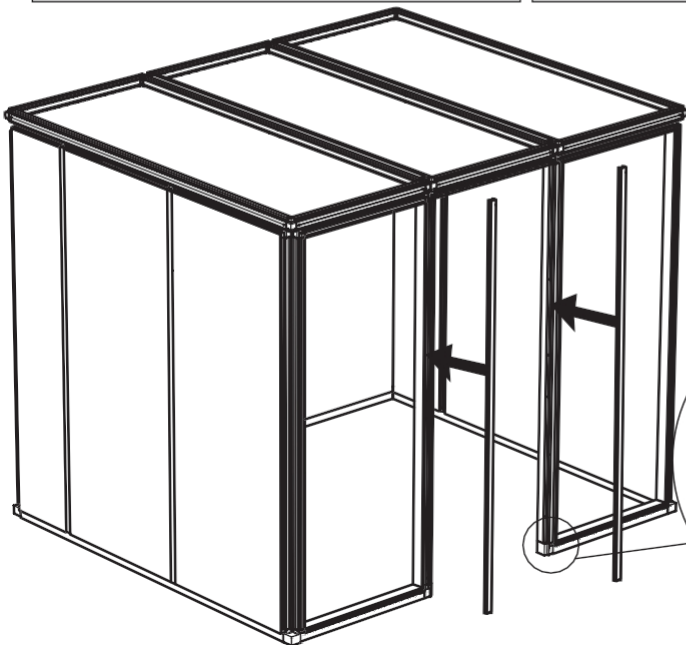
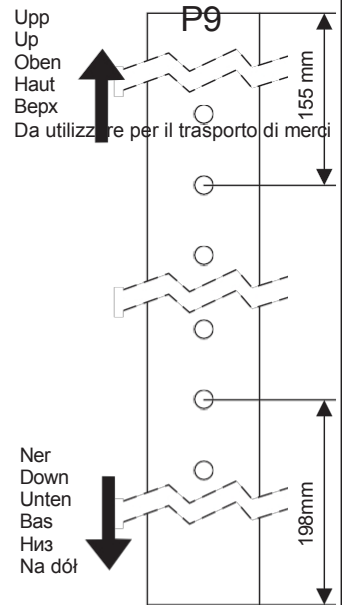
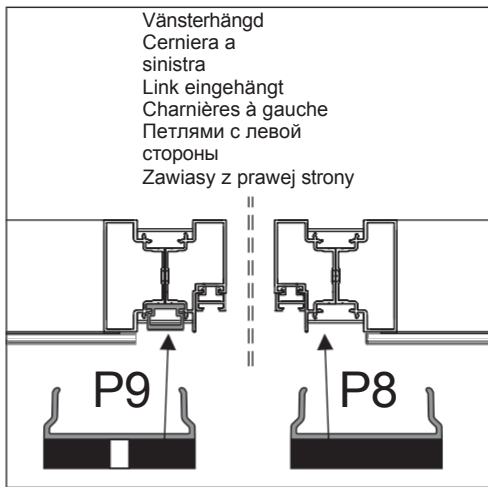
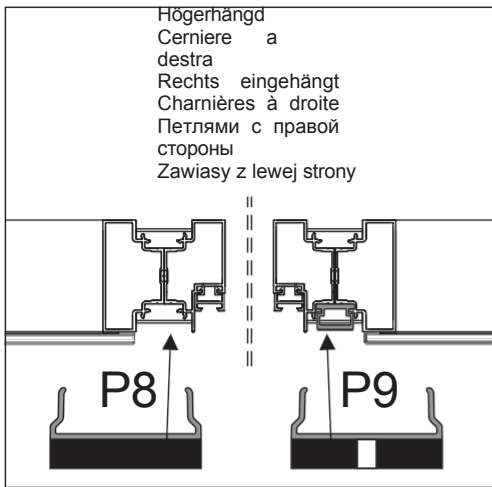
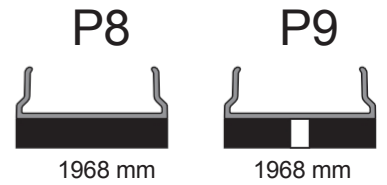
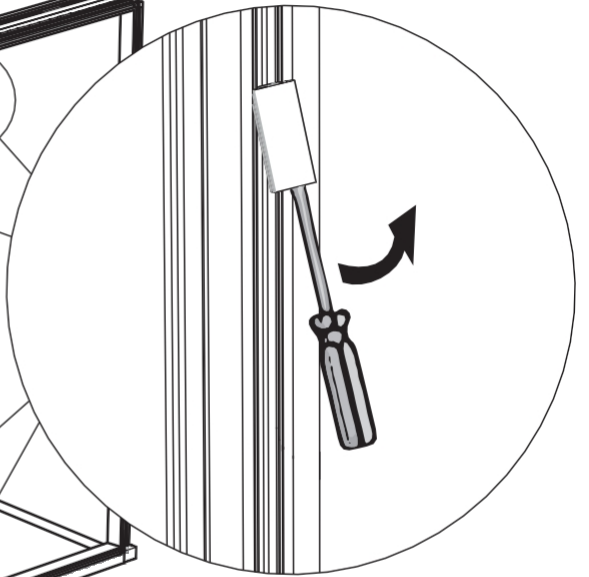
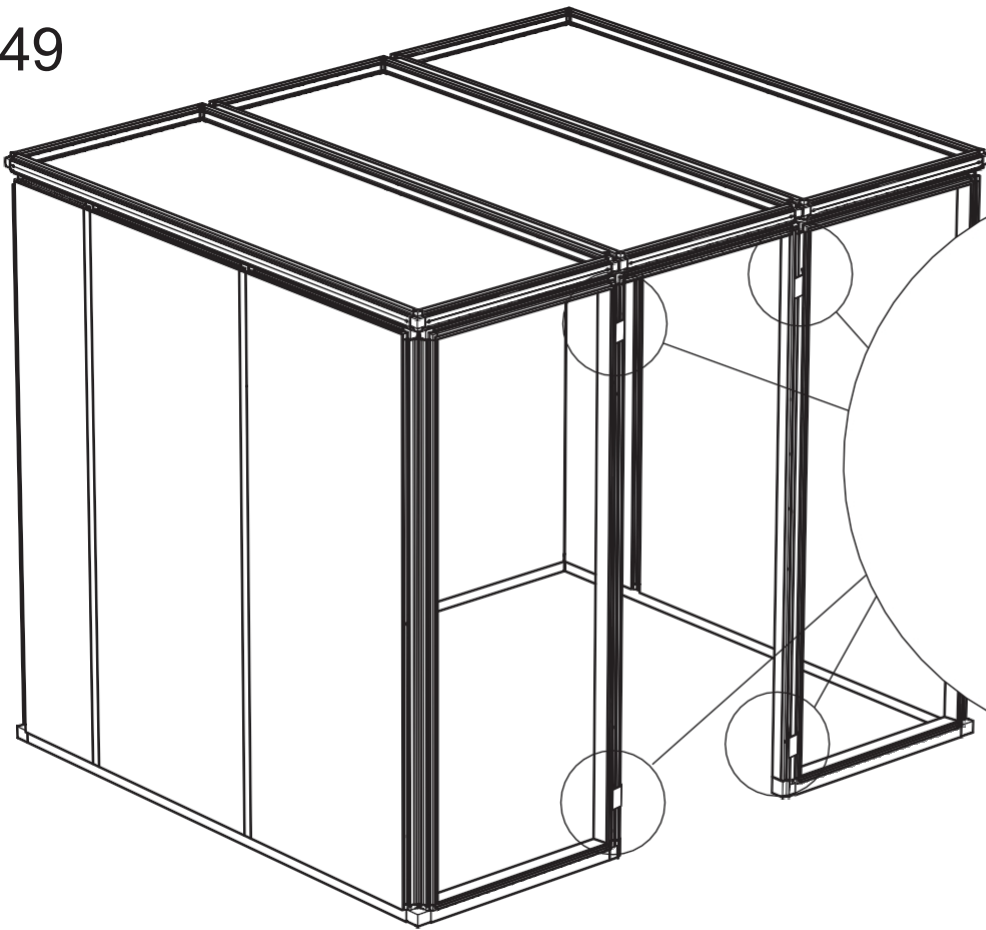

50

x20

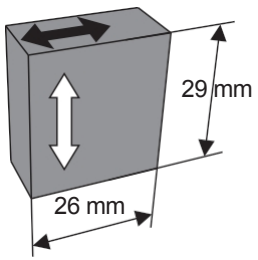

OBS!  
NOTA!  
ACHTUNG!  
ATTENZIONE  
!  
Внимание!

Insida  
Inside  
Innenseite  
Intérieur  
Внутр.  
Wewnařtz

1

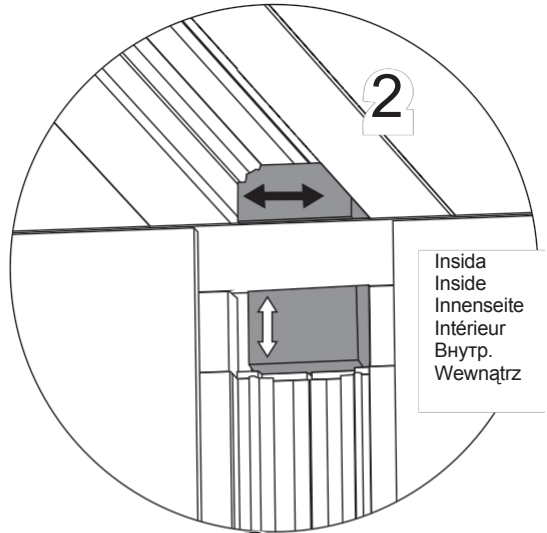
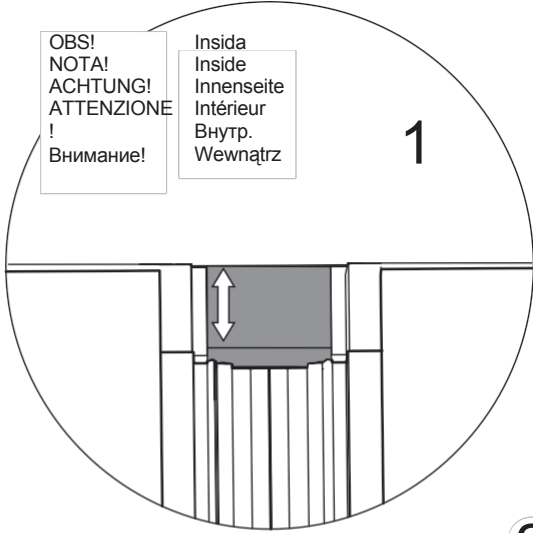

Insida  
Inside  
Innenseite  
Intérieur  
Внутр.  
Wewnařtz

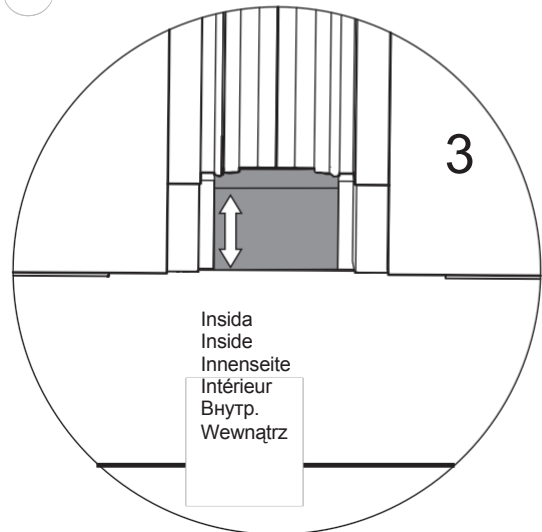
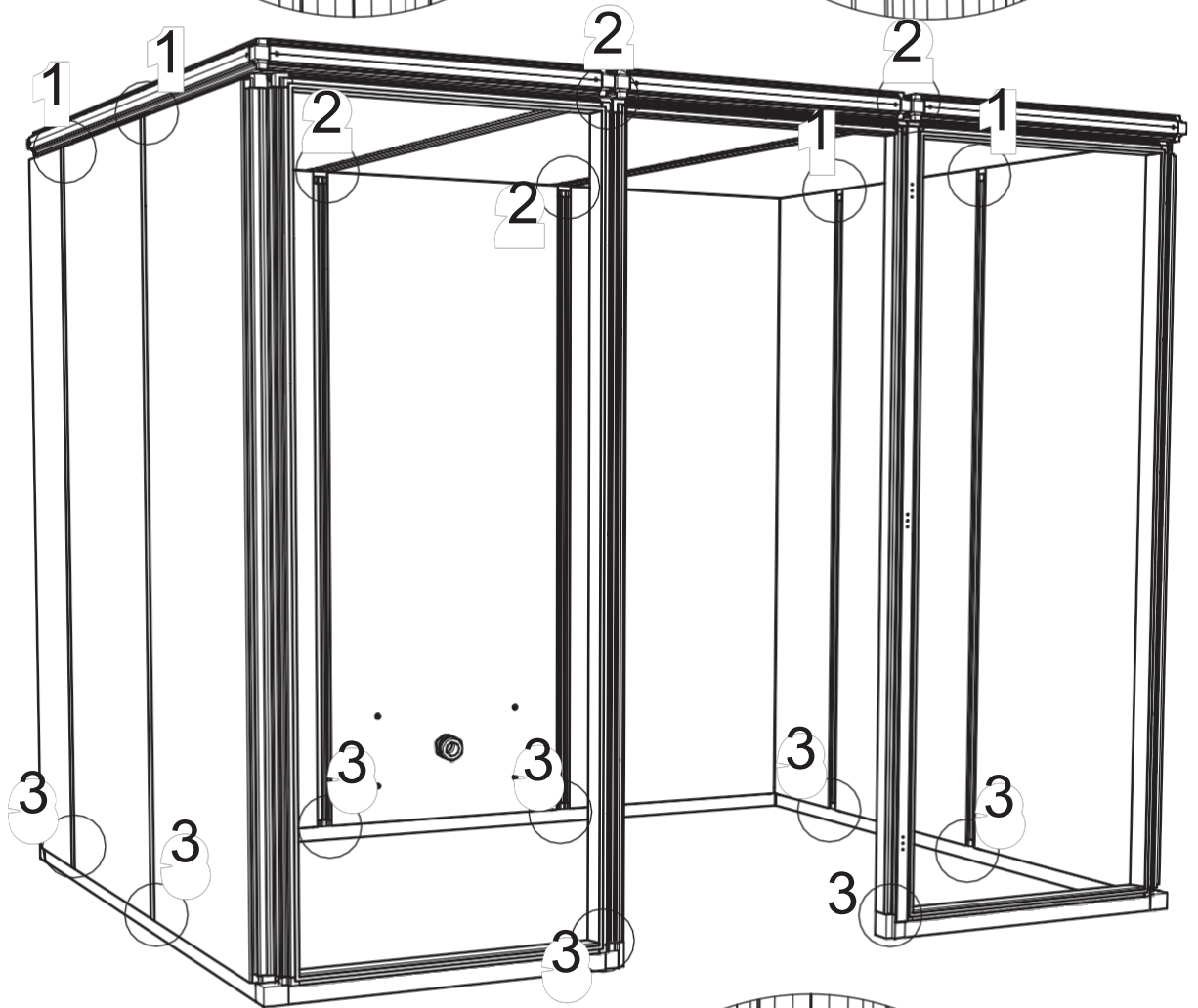

Insida  
Inside  
Innenseite  
Intérieur  
Внутр.  
Wewnařtz

51

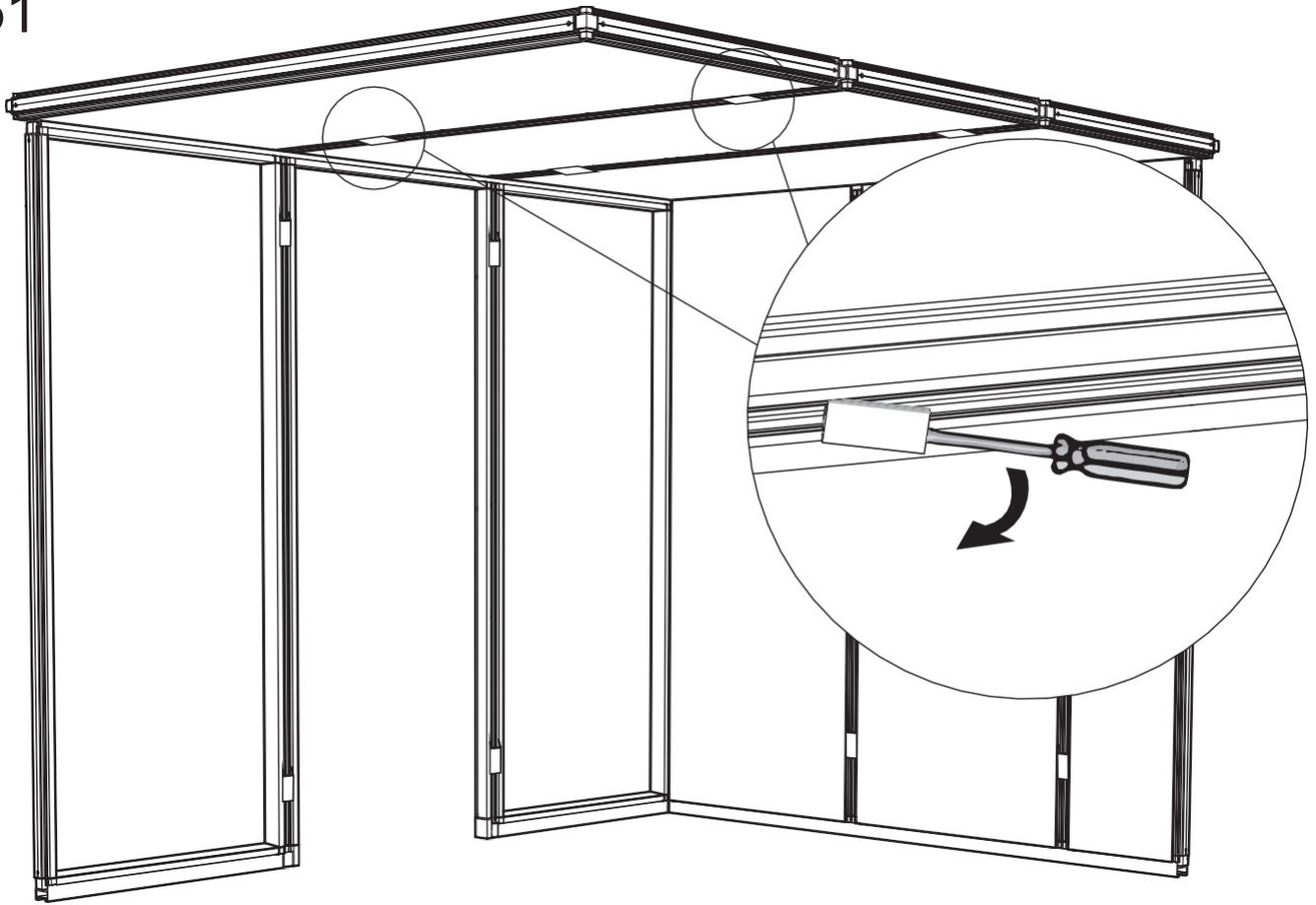

P11



1x1962,5mm

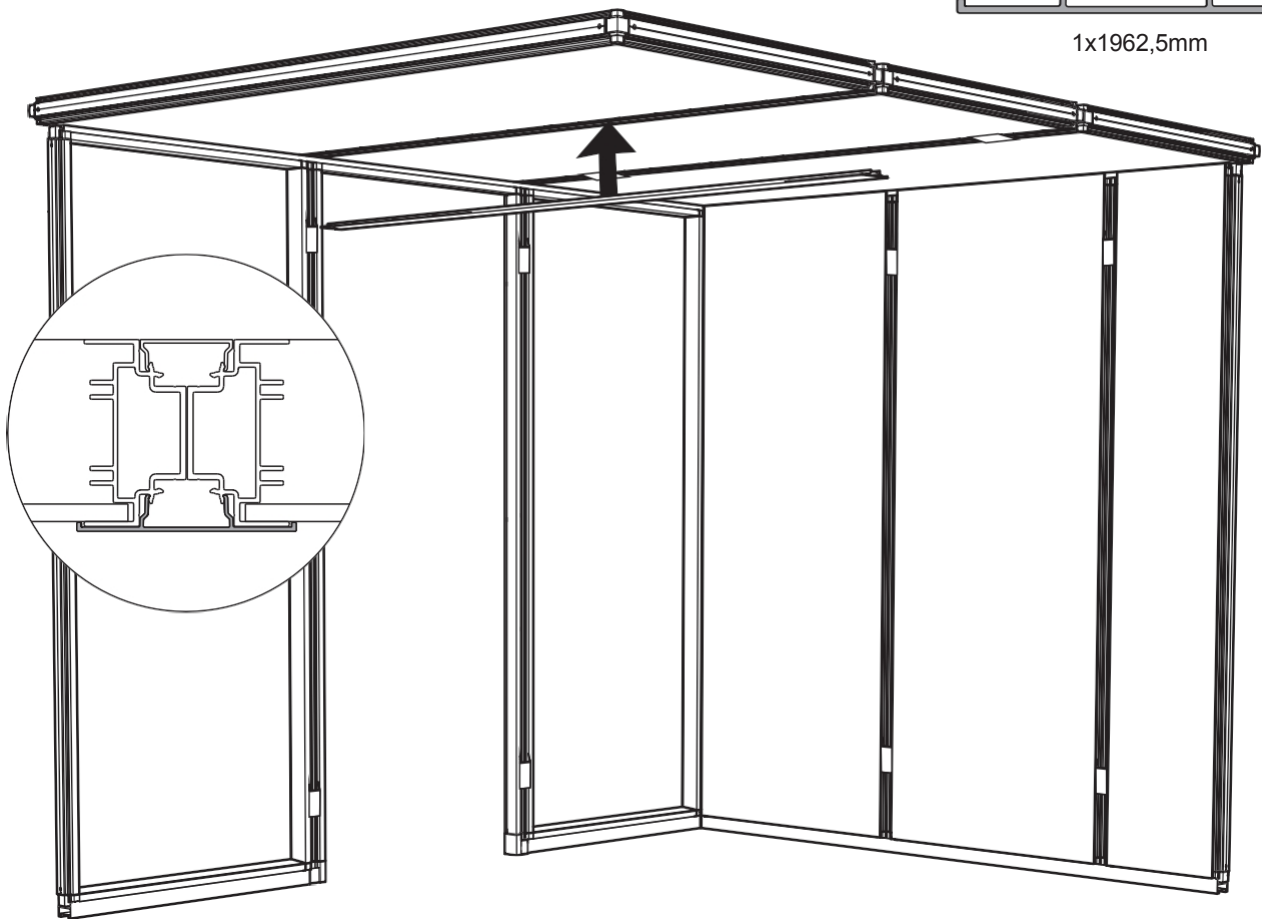

52

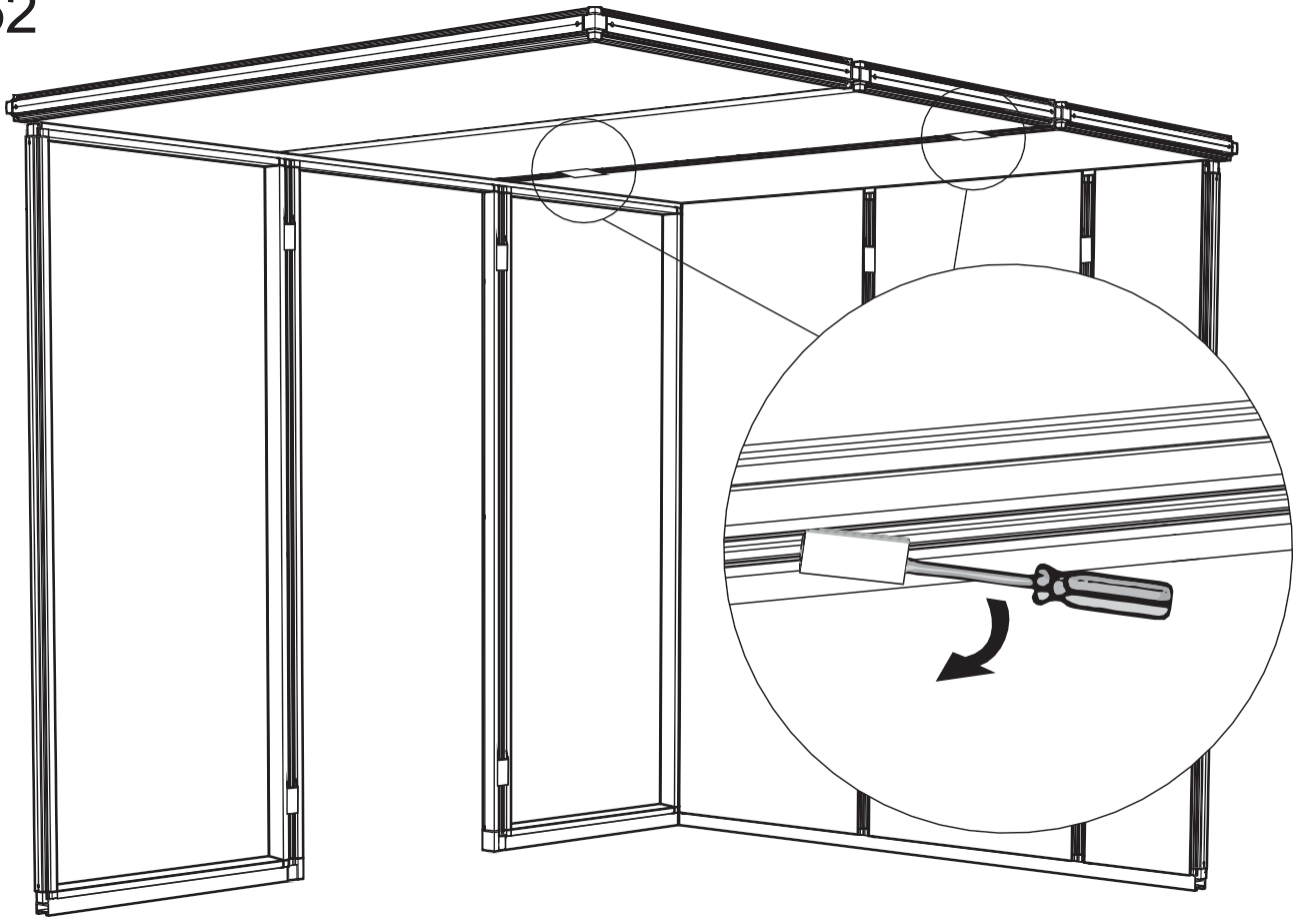

P11



1x1962,5mm

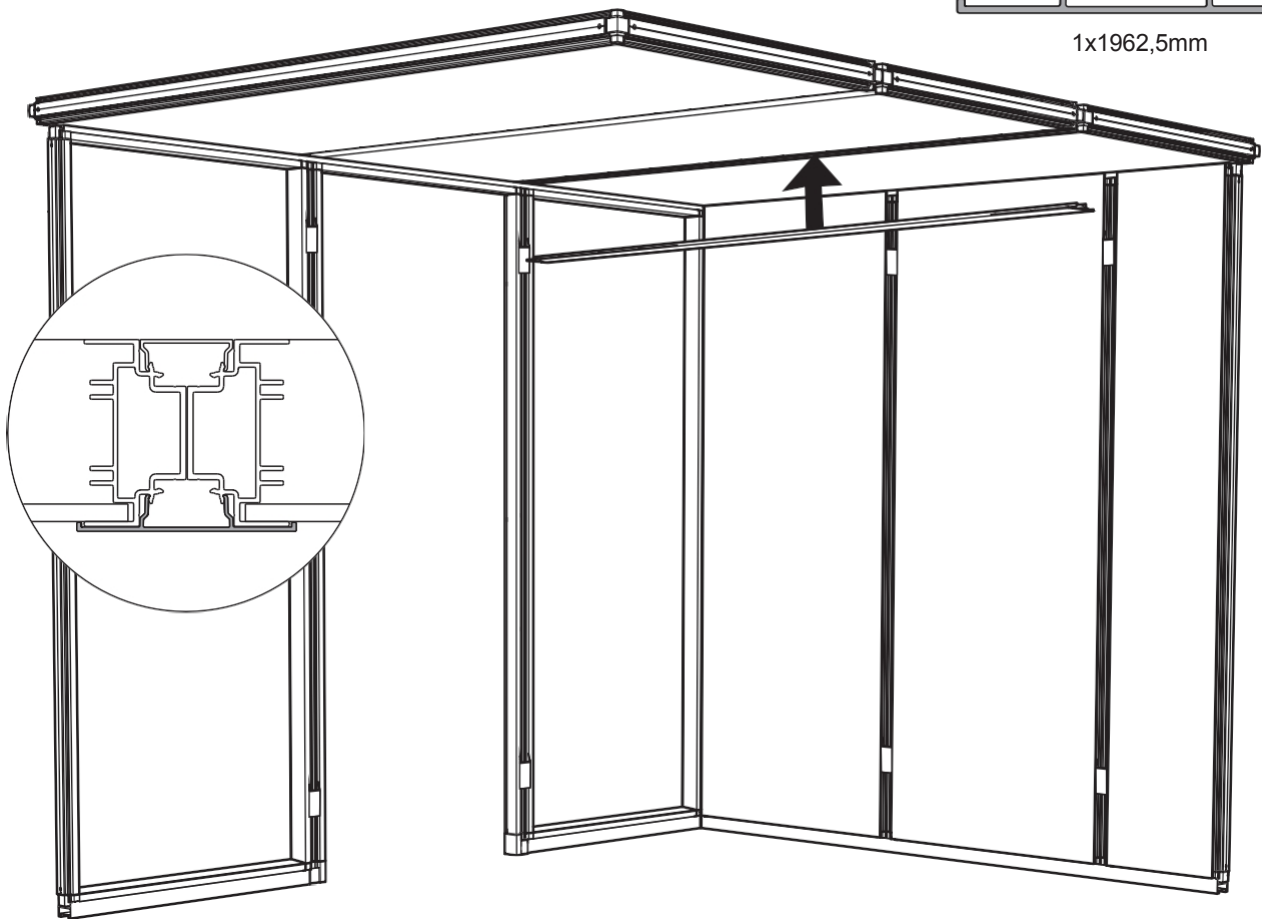

53

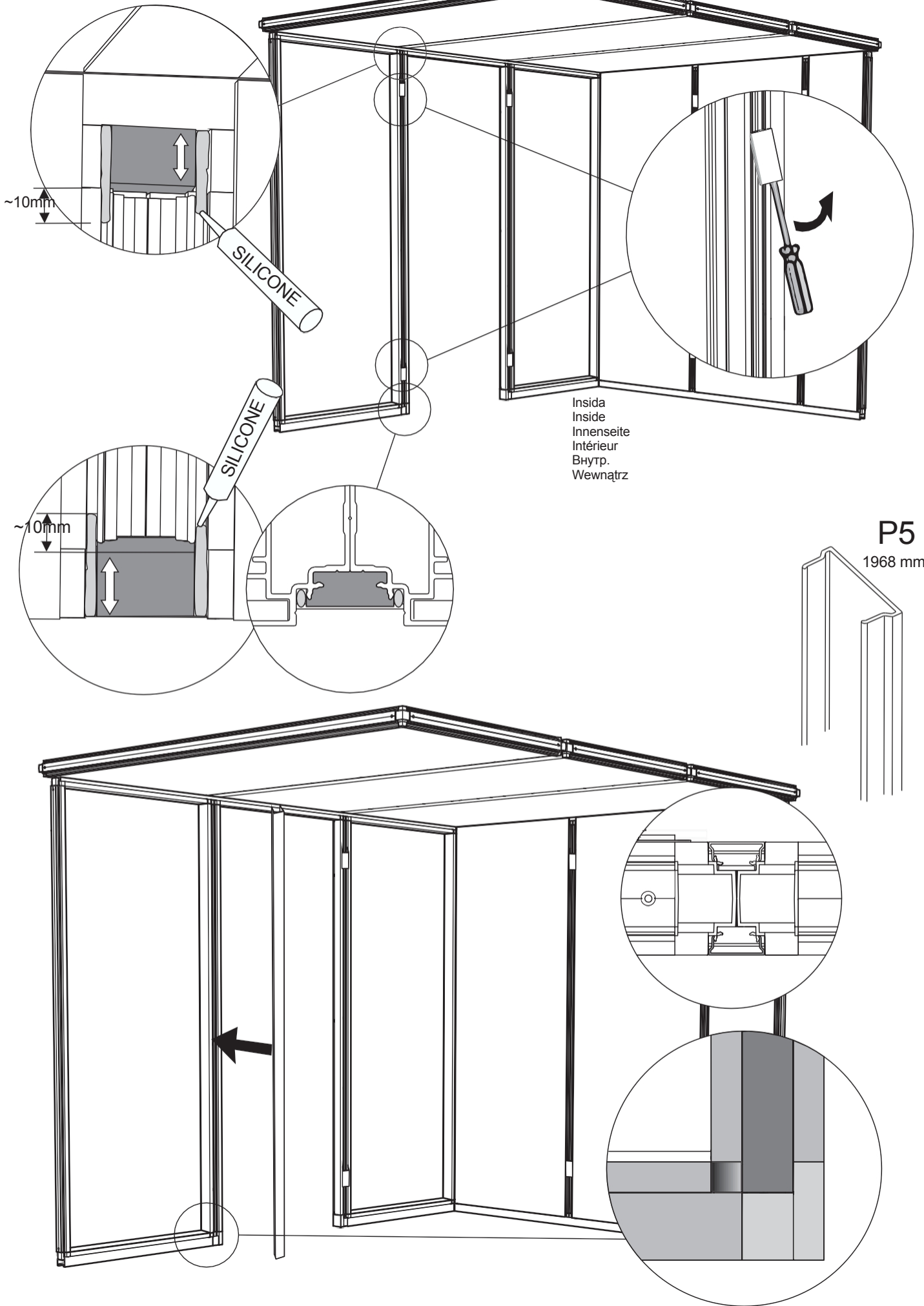

Insida  
Inside  
Innenseite  
Intérieur  
Внутр.  
Wewnątrz

P5  
1968 mm

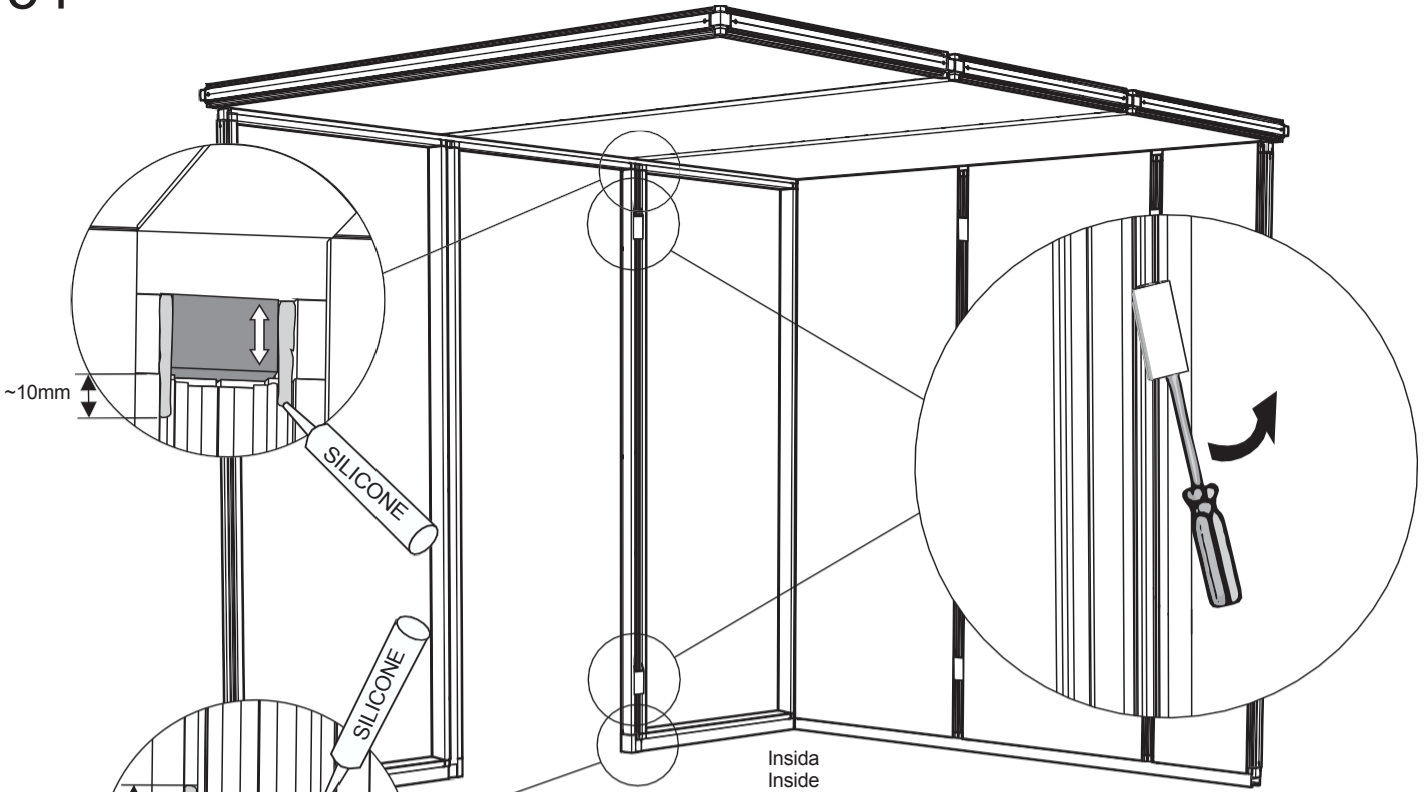

Insida  
Inside  
Innenseite  
Intérieur  
Внутр.  
Wewnařtz

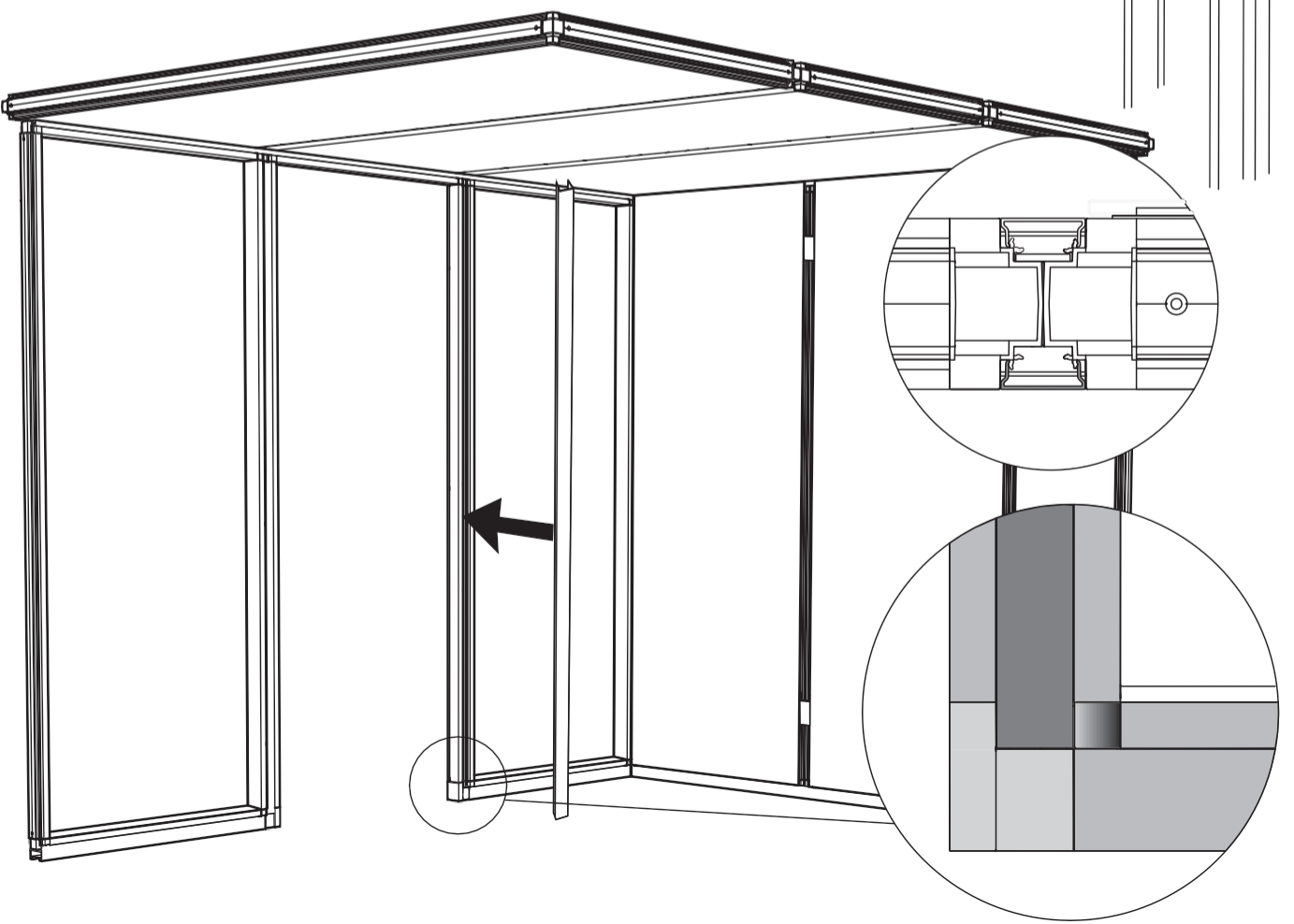
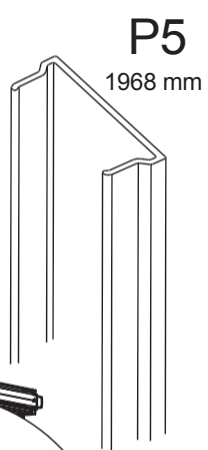



56

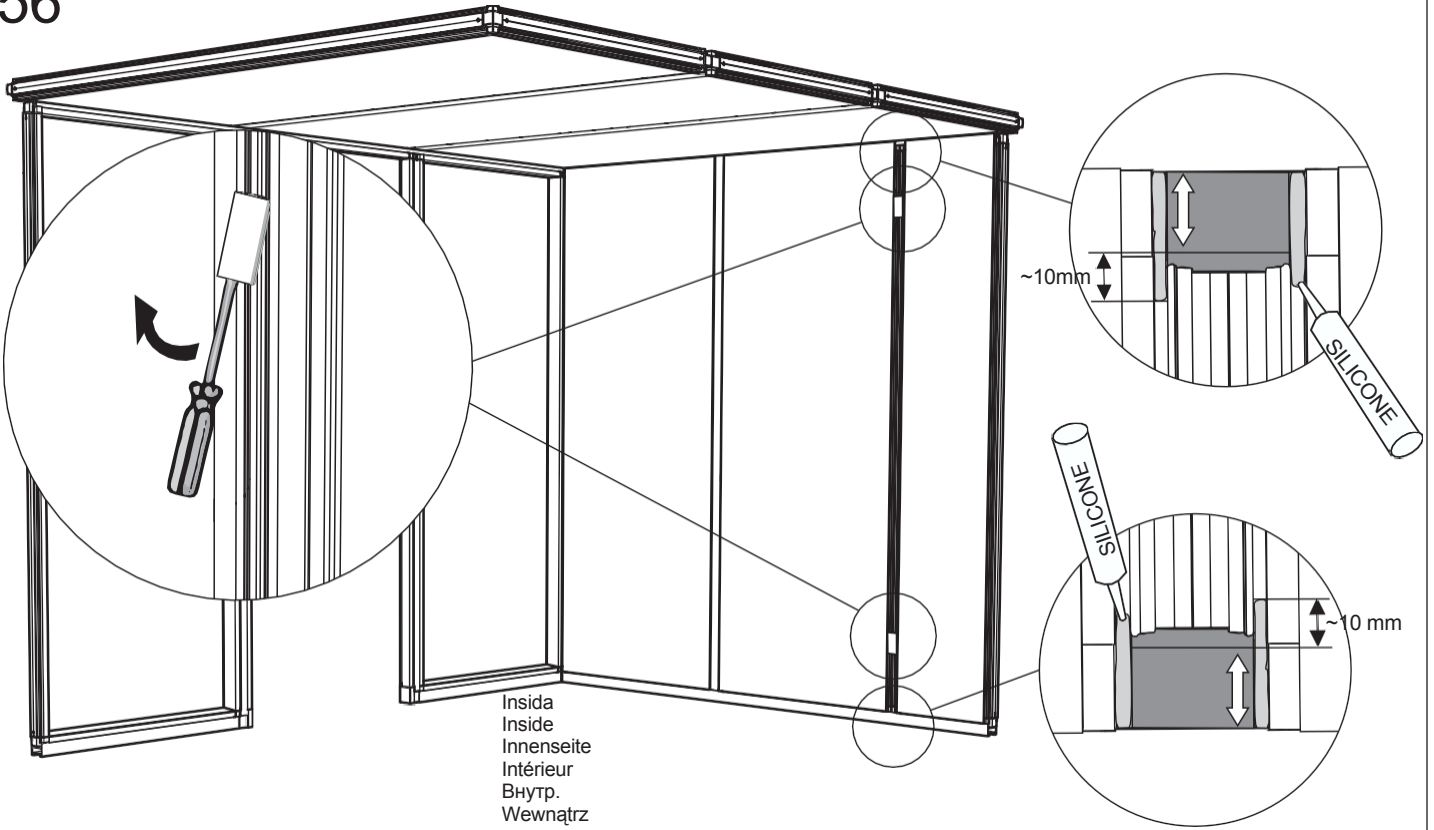

P10<sub>px</sub>

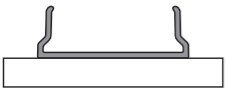

1x1980mm

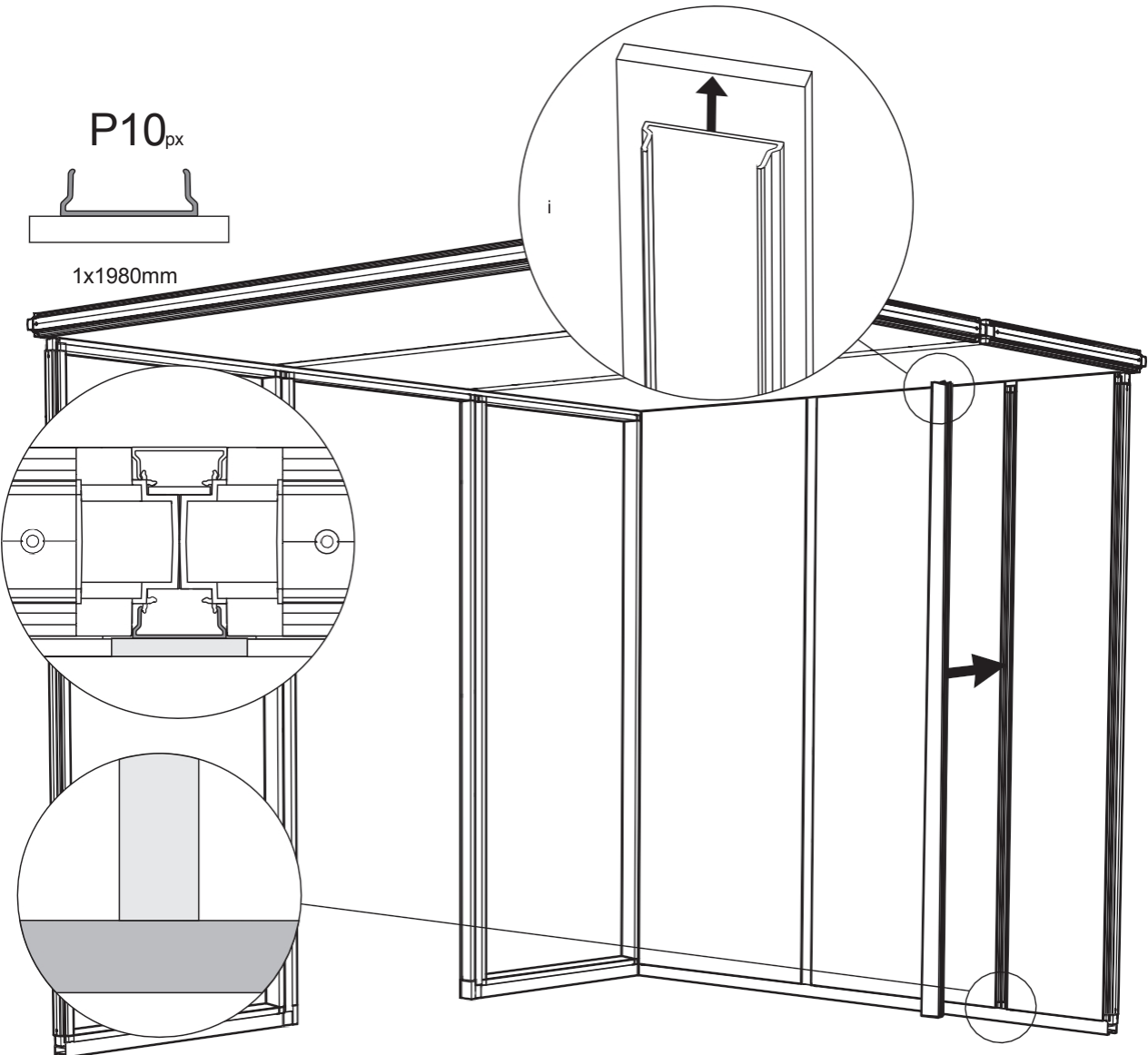

57

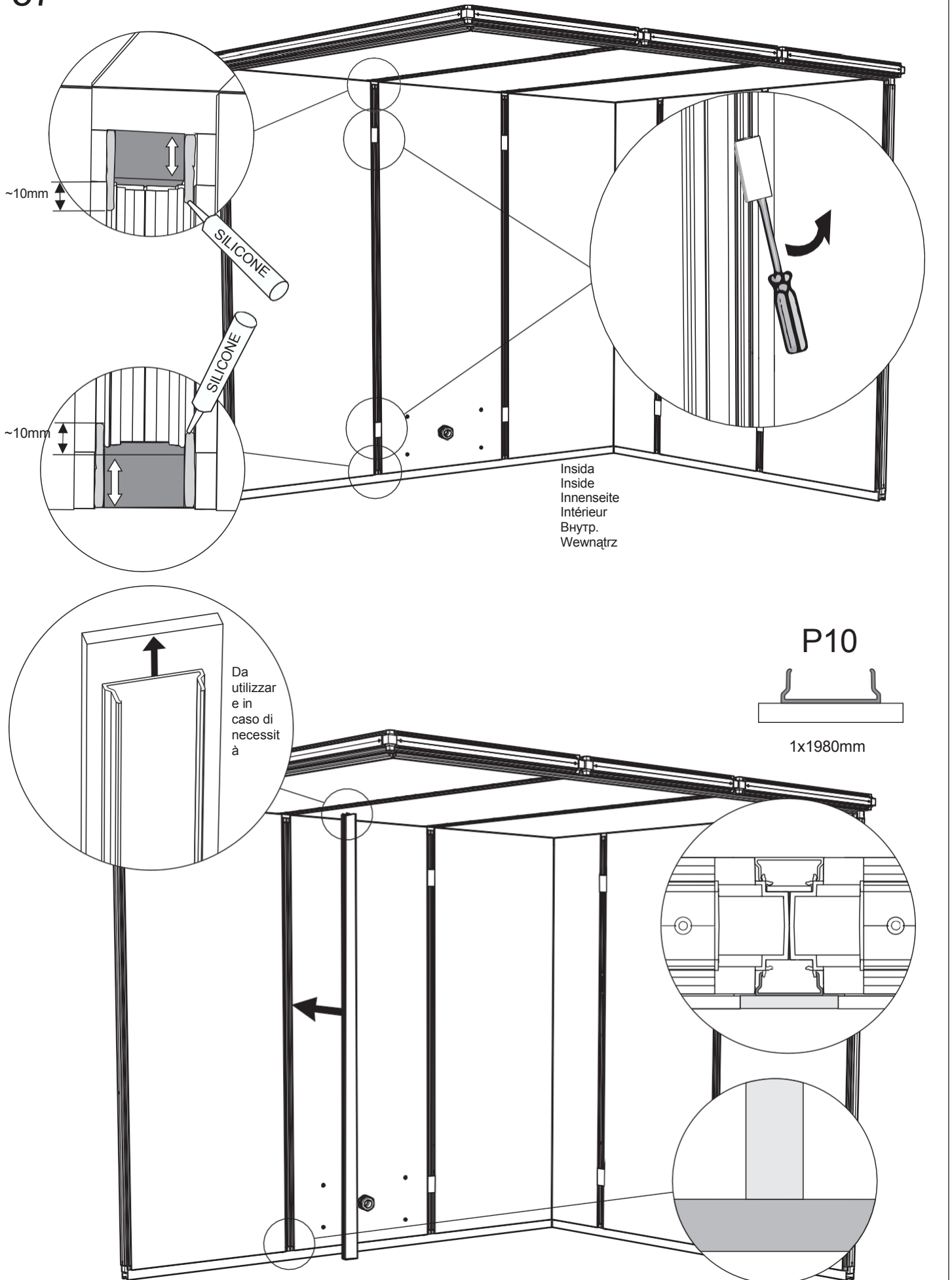

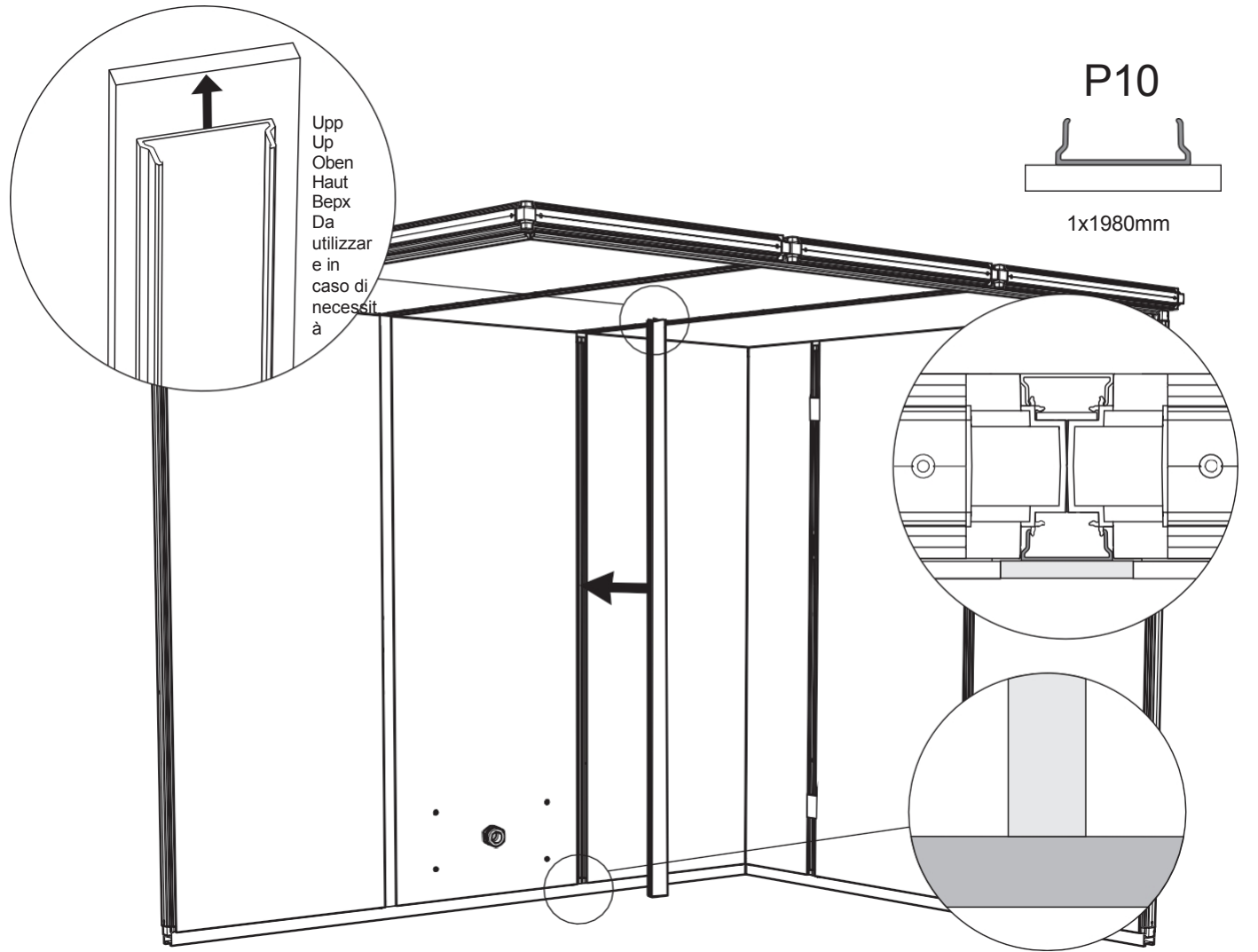
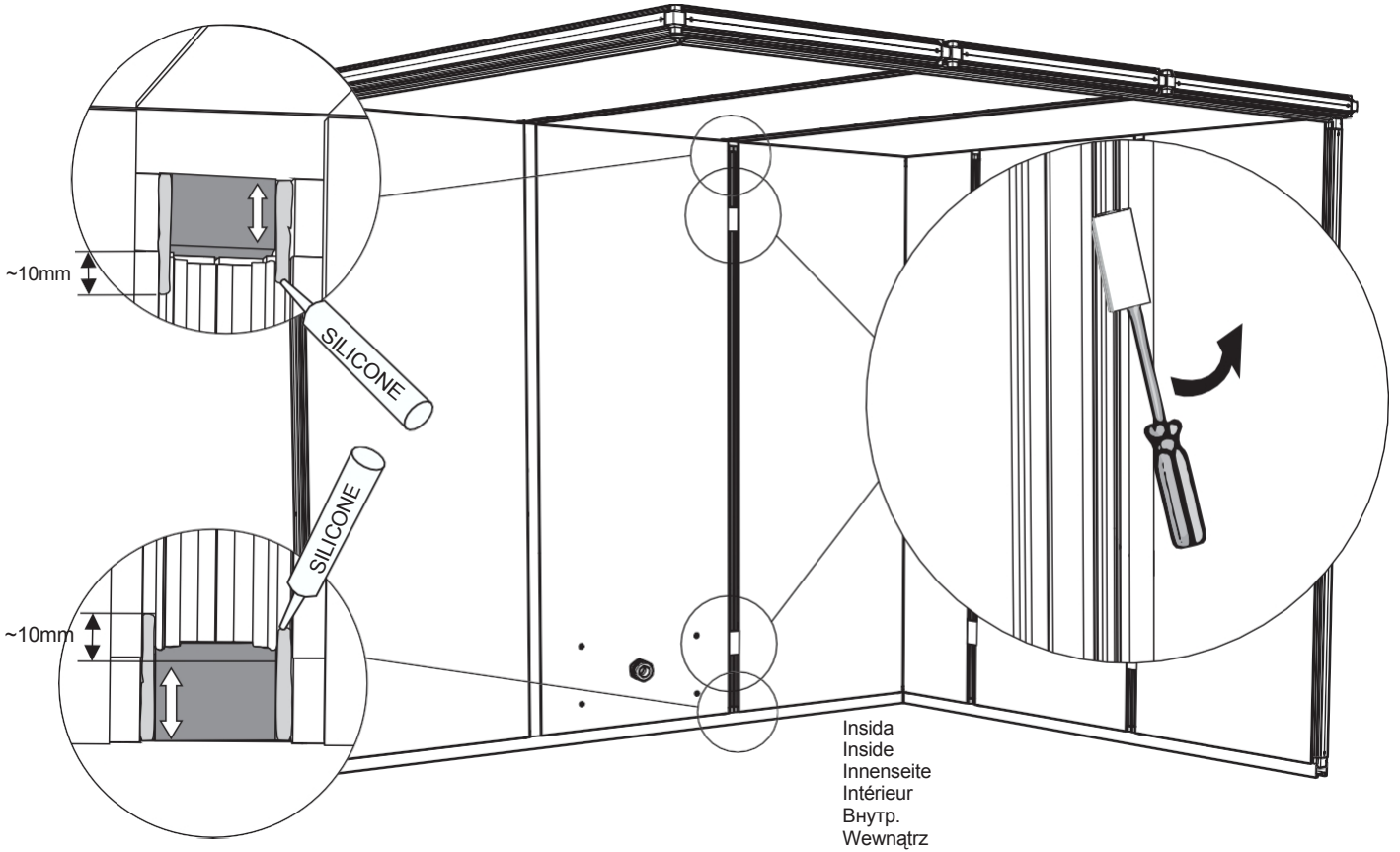



60

sezione per il vapore

Posizionamento del termistore (sensore)

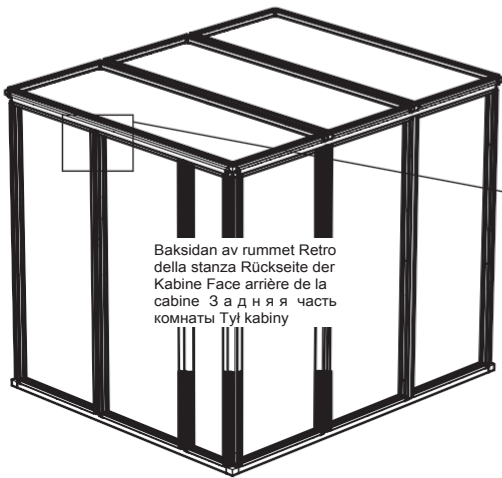
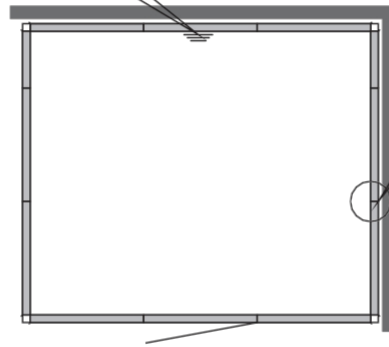

Baksidan av rummet Retro della stanza Rückseite der Kabine Face arrière de la cabine 3 а д н я часть комнаты Тул kabiny

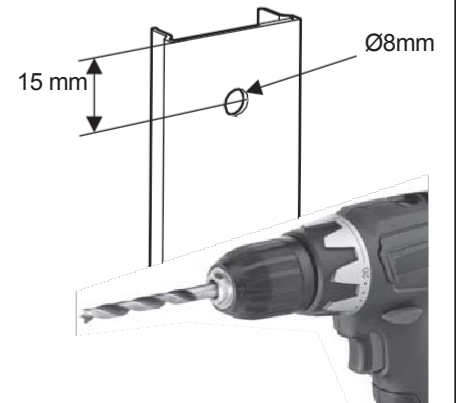
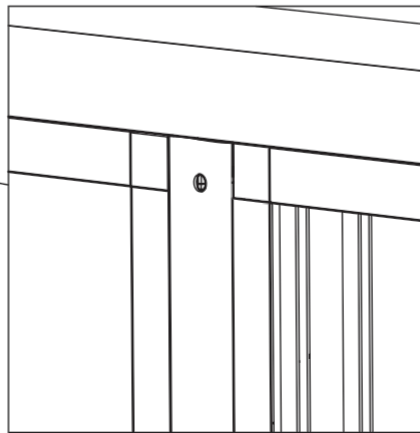

P10-T

(4m)

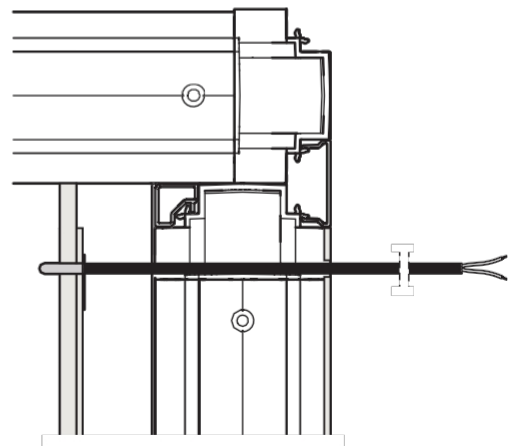
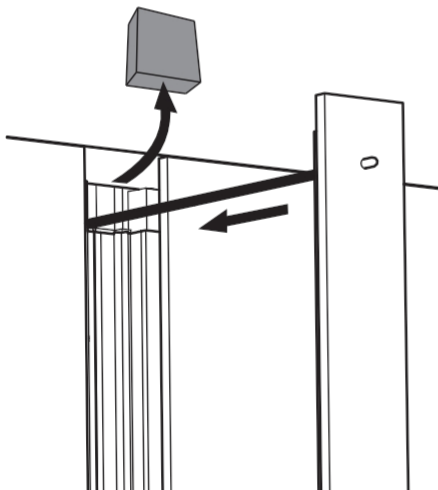
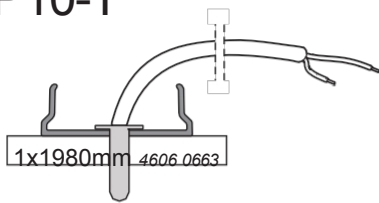

61

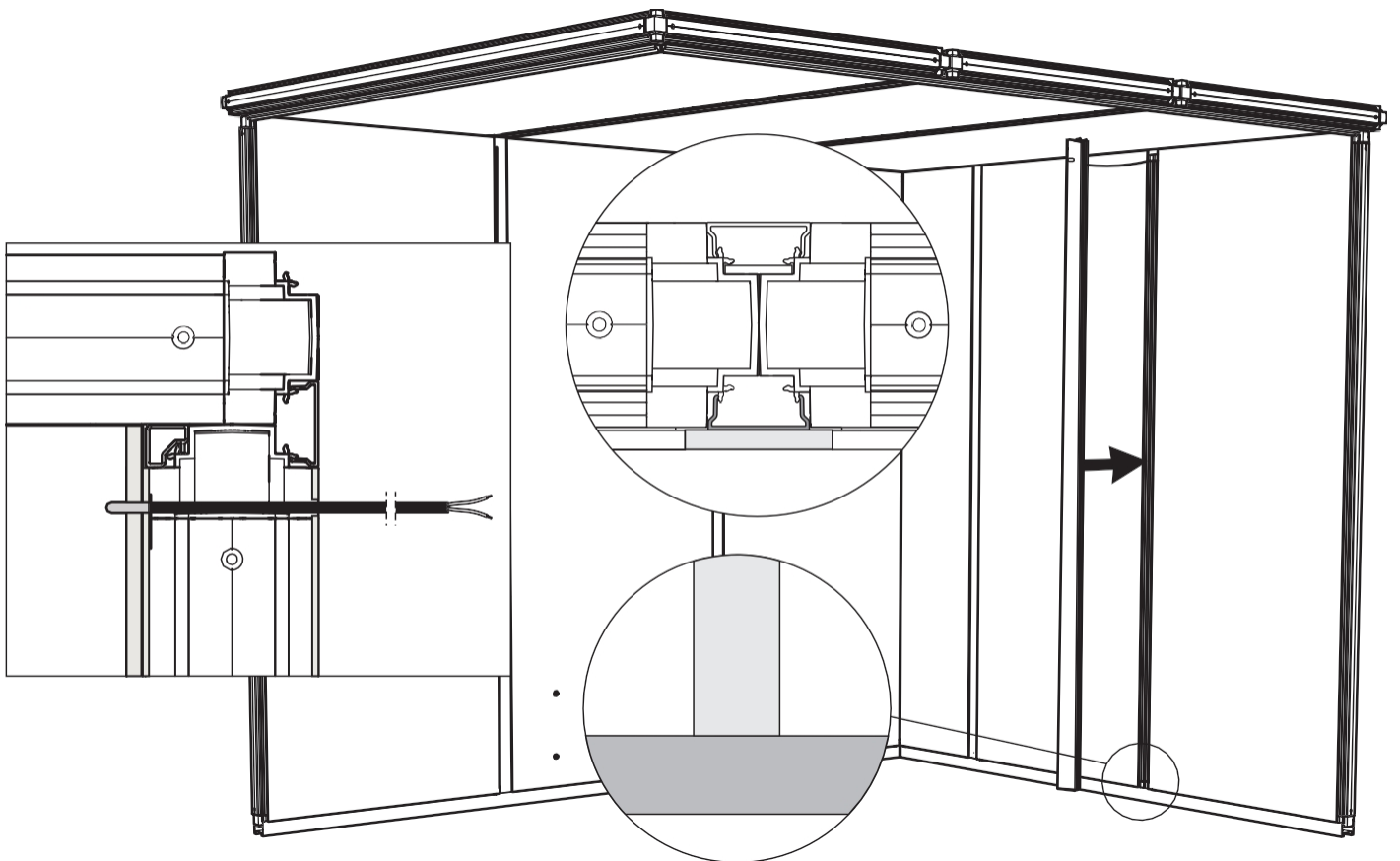
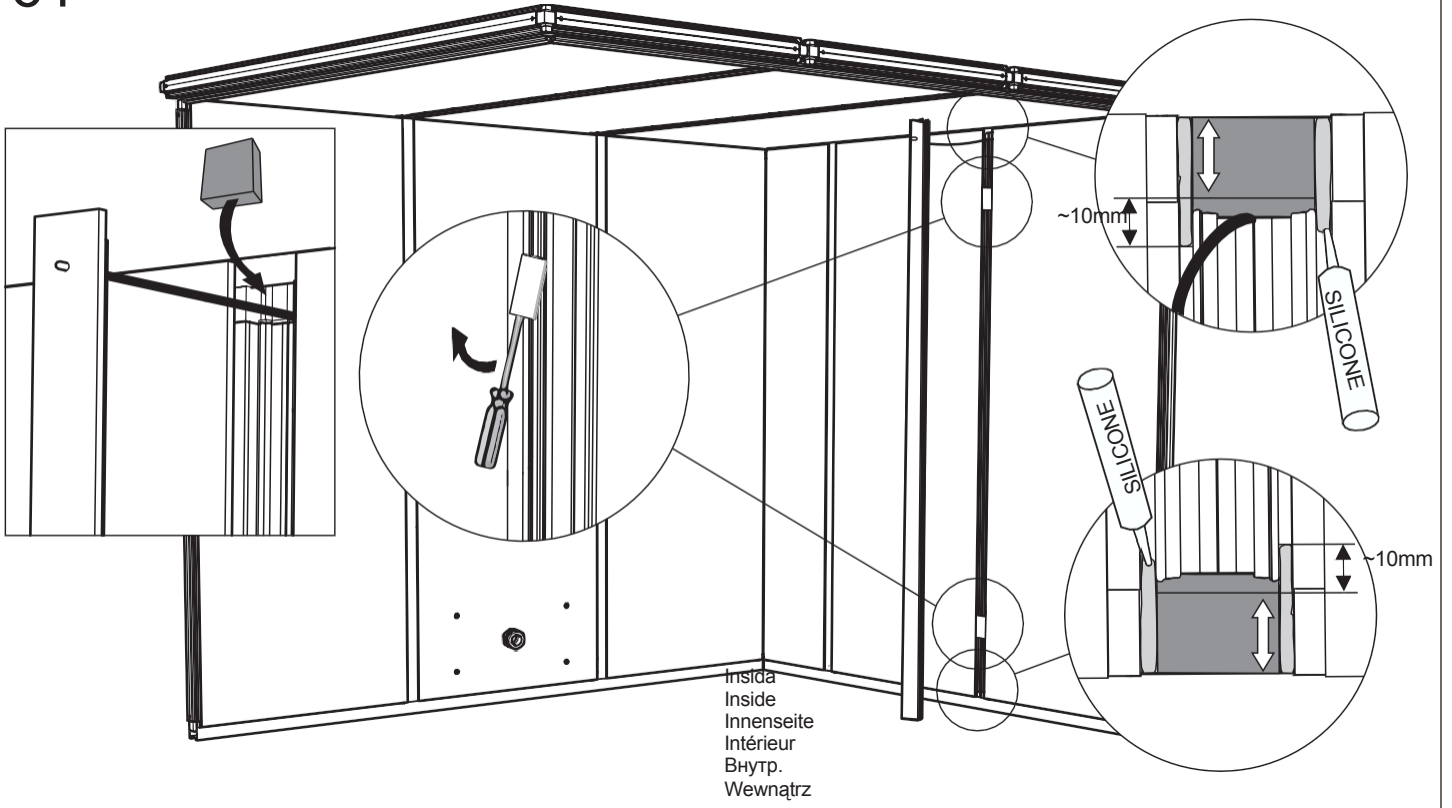



Ø 10 mm

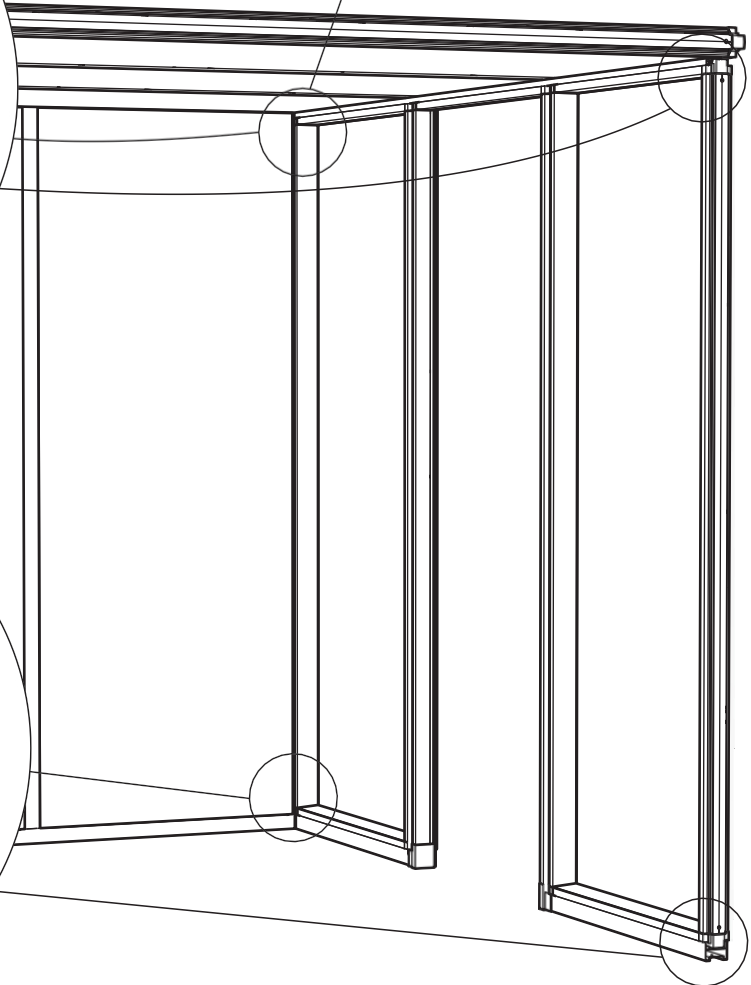
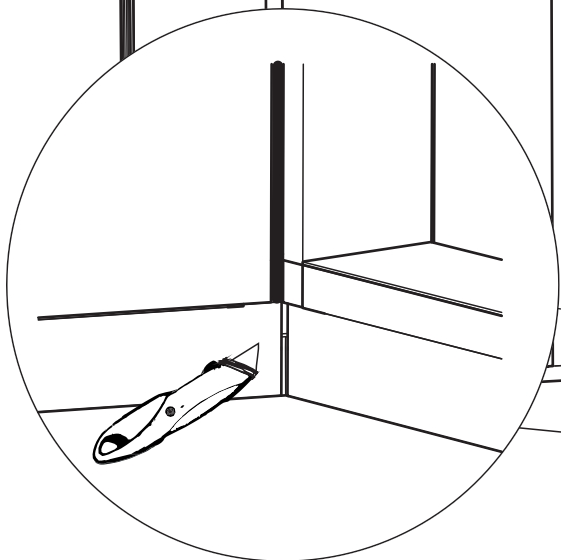
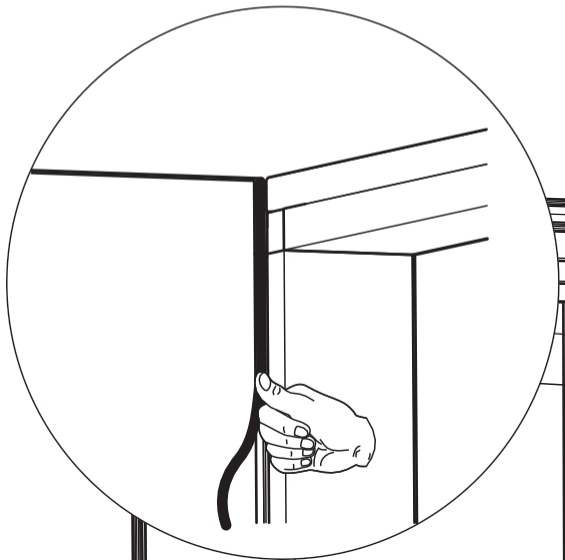
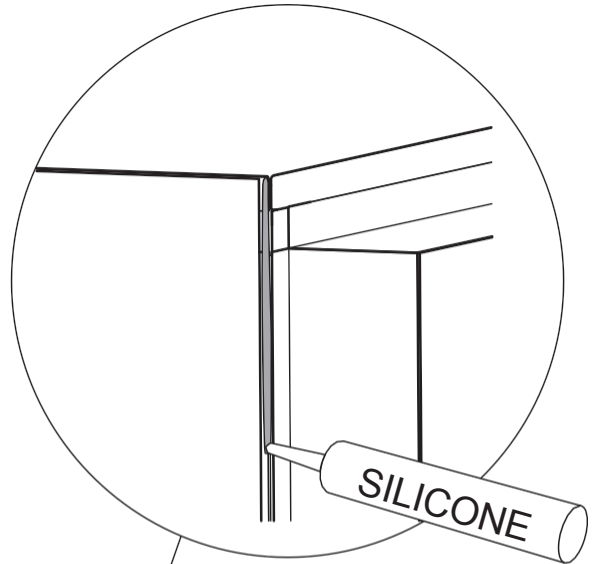
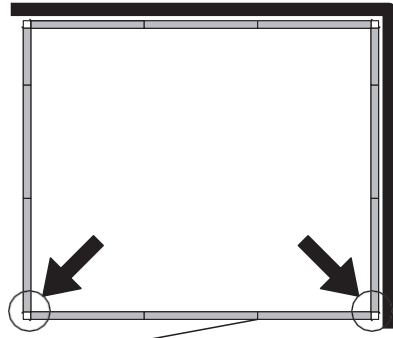

63

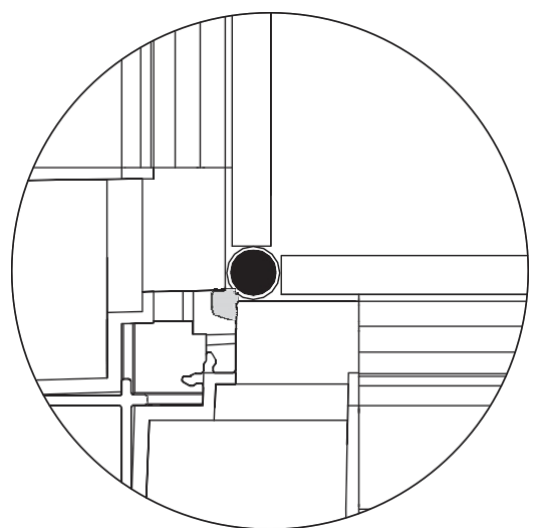
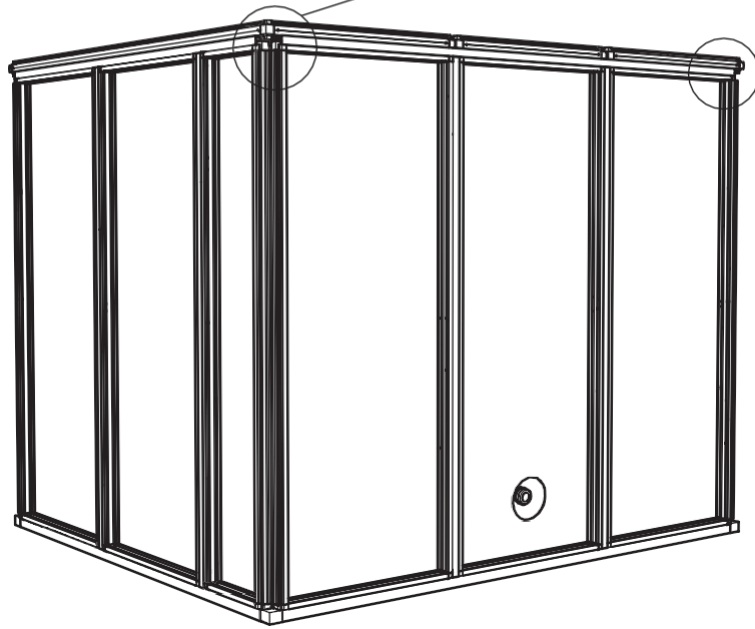
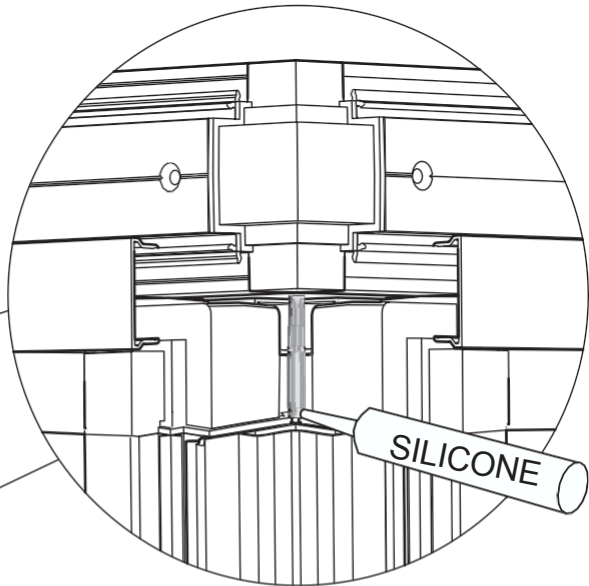
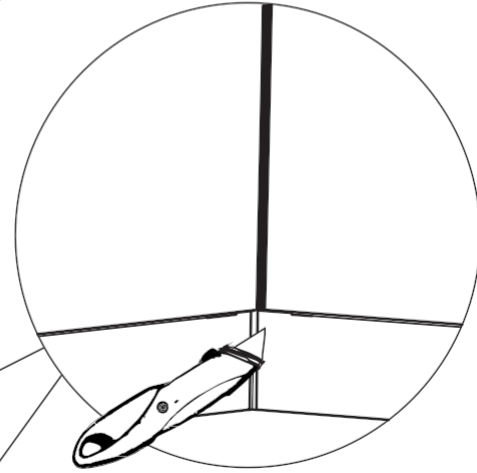
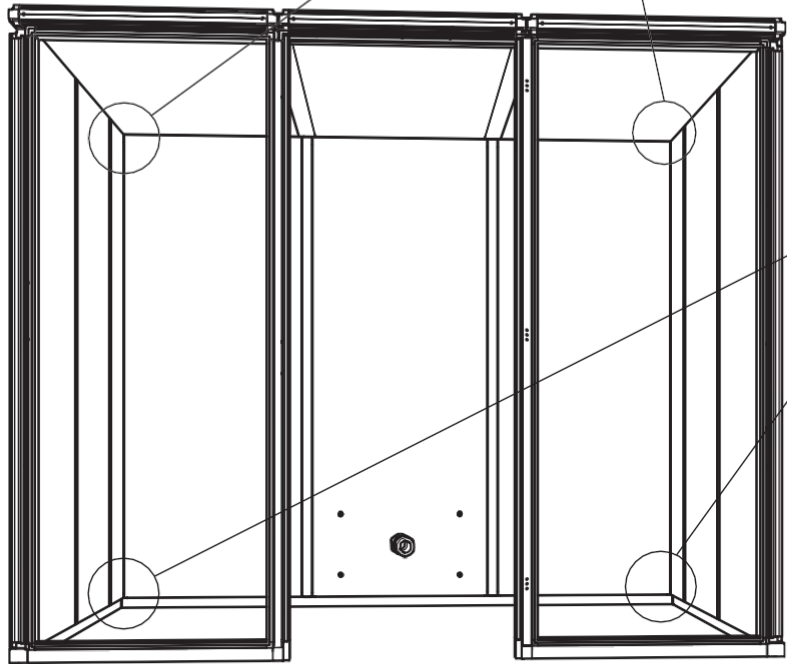
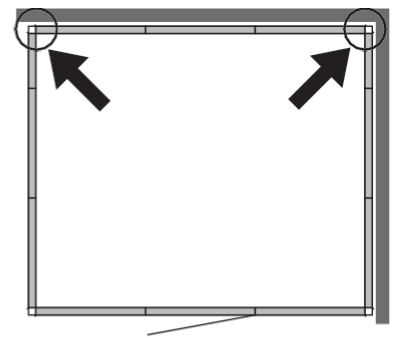
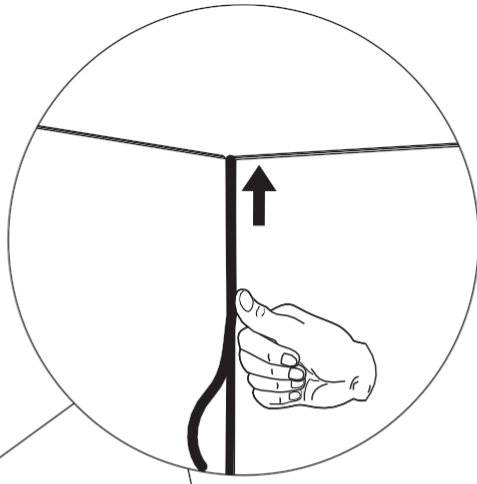
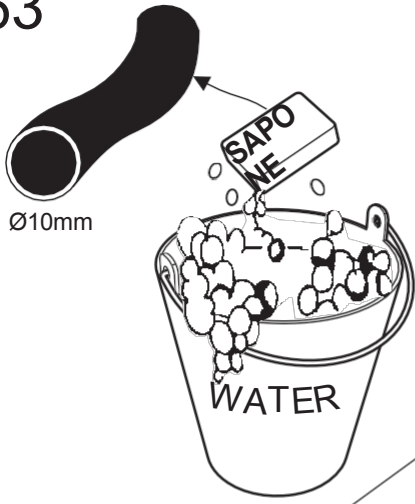

64

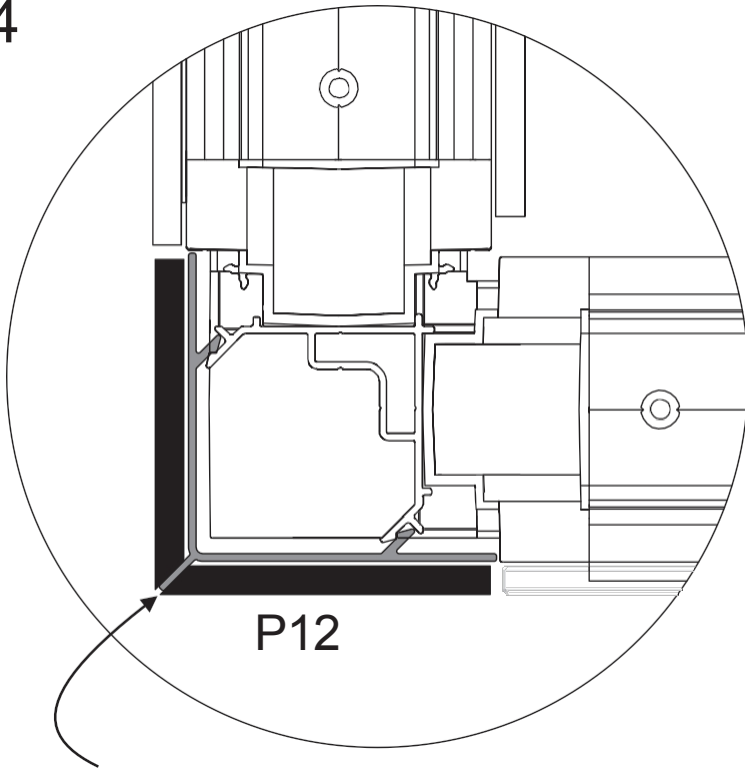

Battere con la mano l'angolo dei profili angolari per fissarli saldamente in posizione. Fissare i profili d'angolo con la mano per fissarli saldamente in posizione.

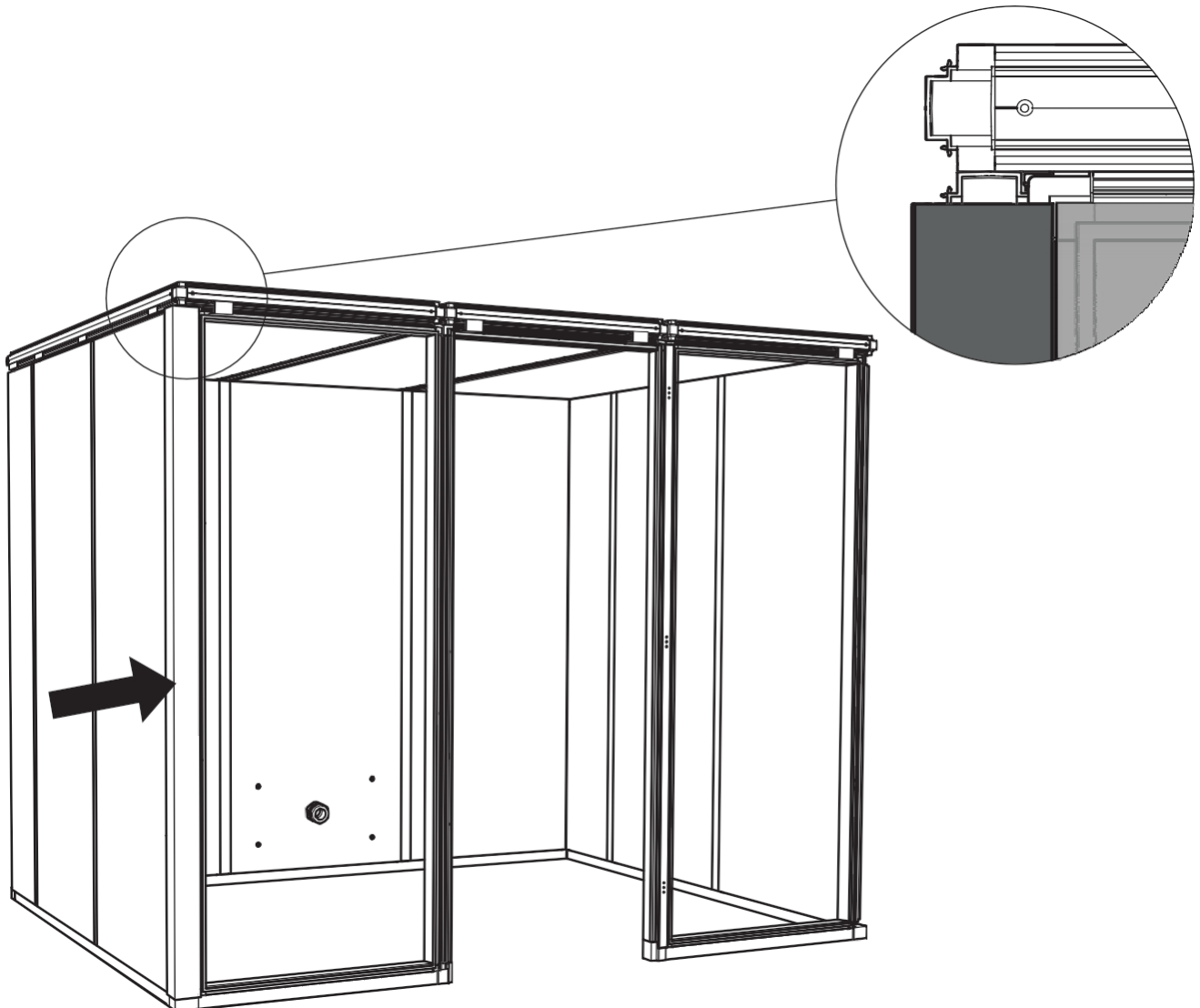

65

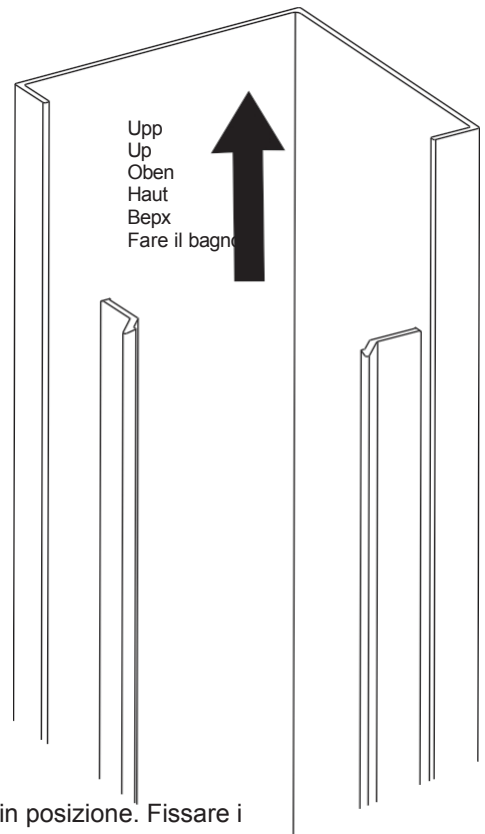
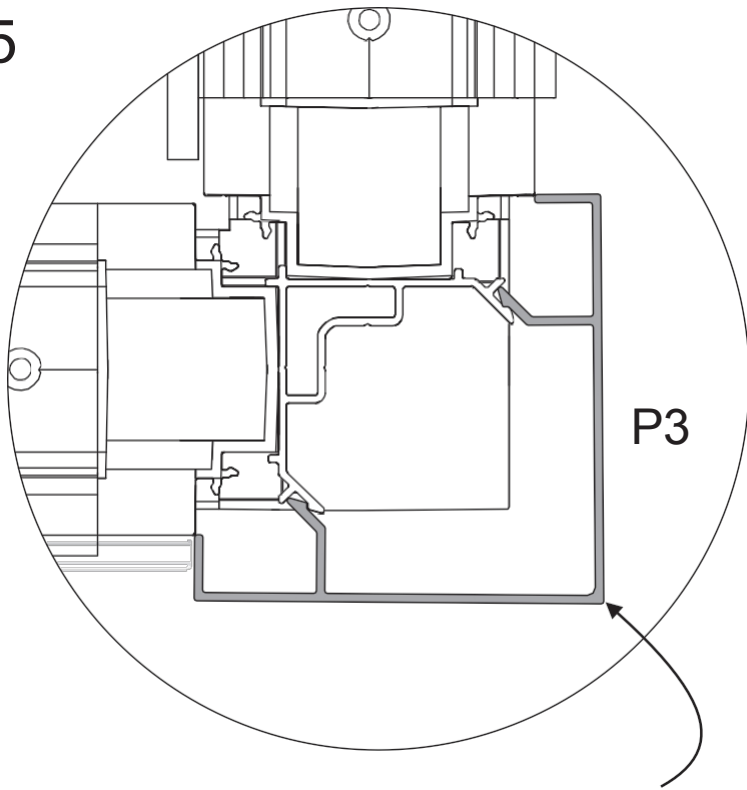

Battere con la mano l'angolo dei profili angolari per fissarli saldamente in posizione. Fissare i profili d'angolo con la mano per fissarli saldamente in posizione.

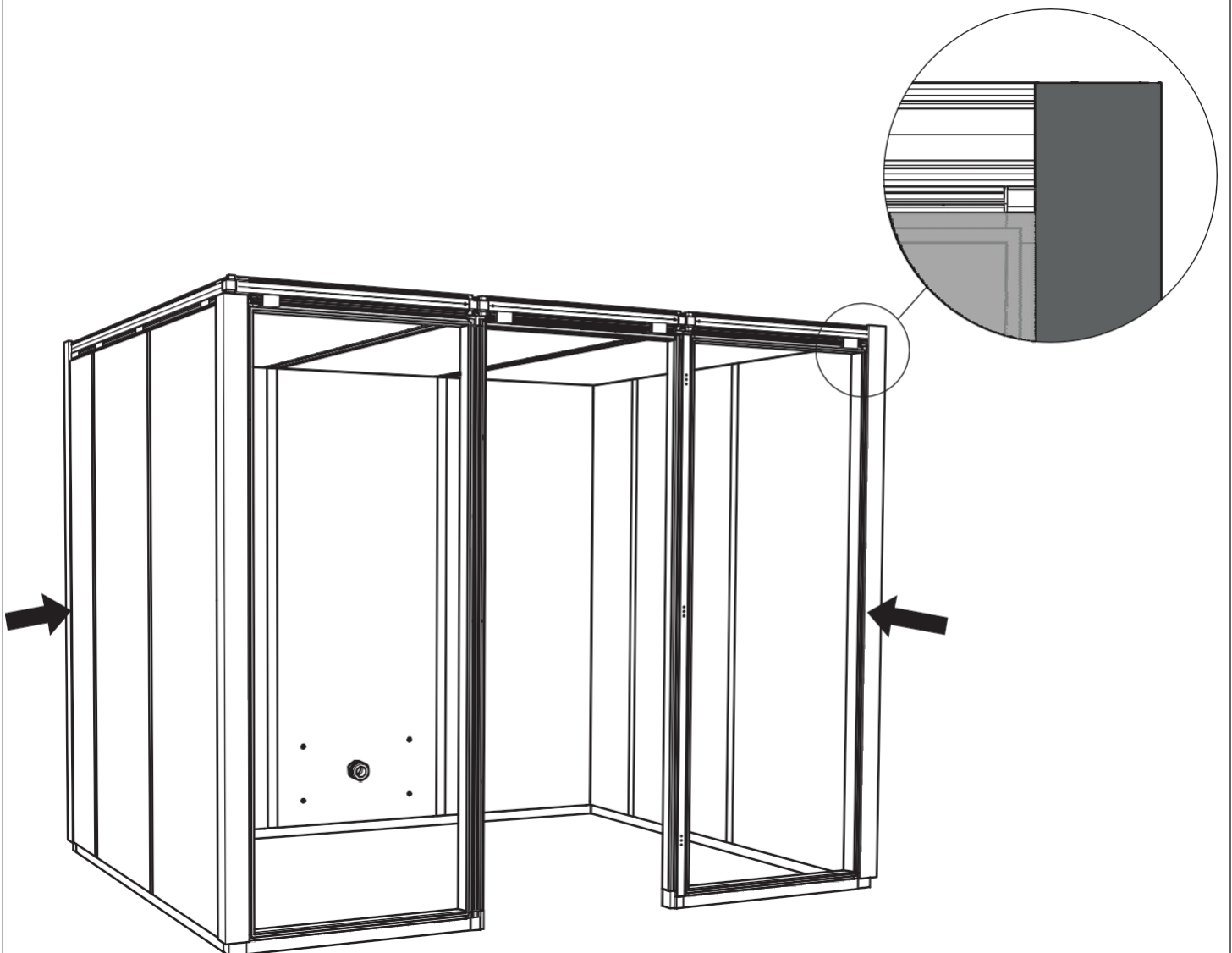

66

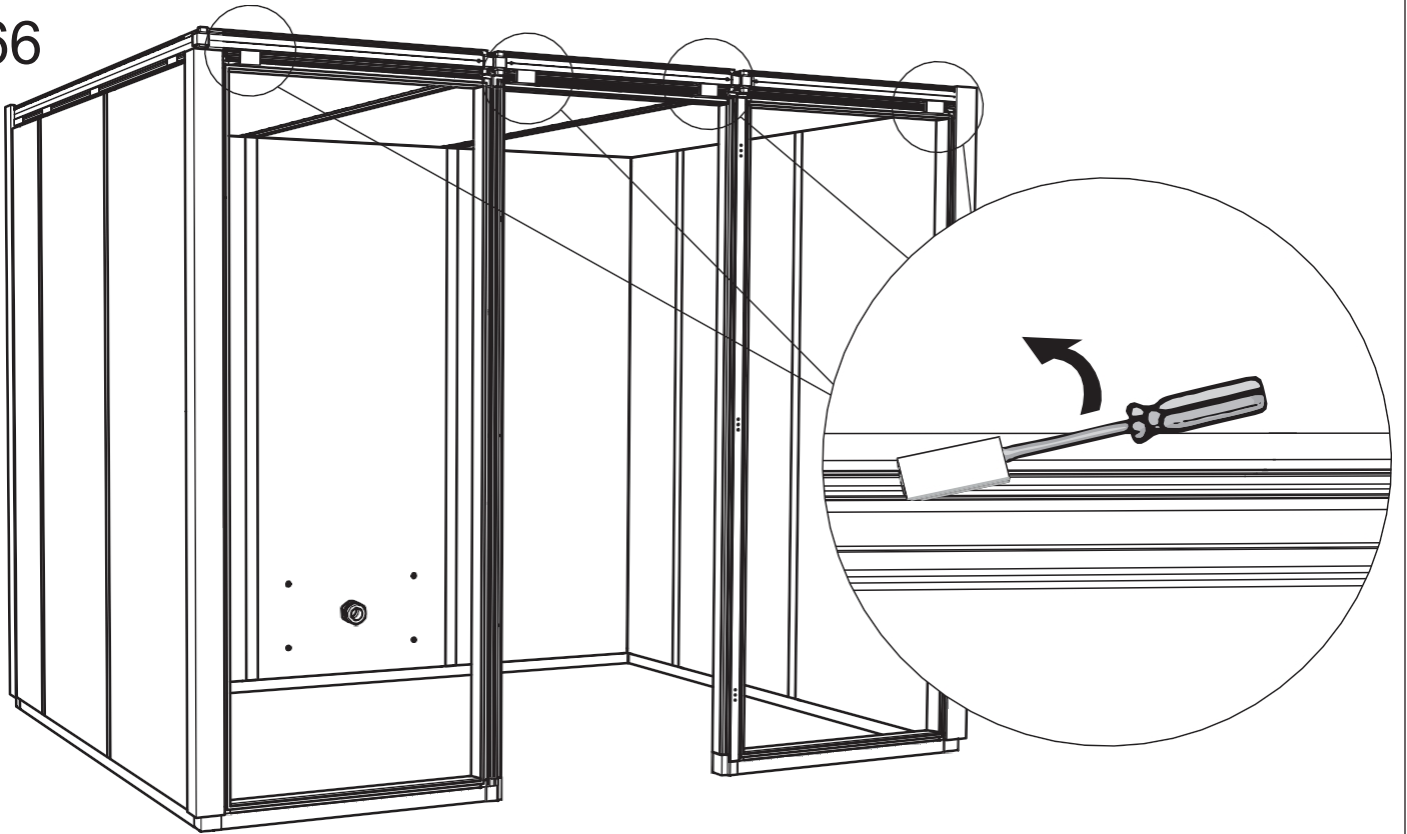

P4

2446 mm

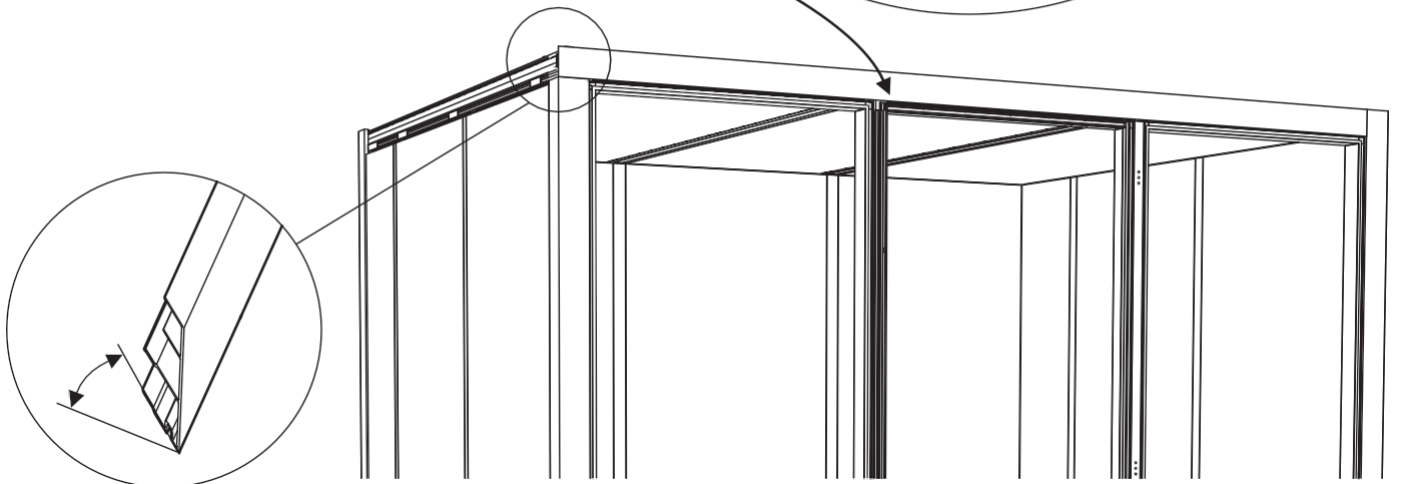
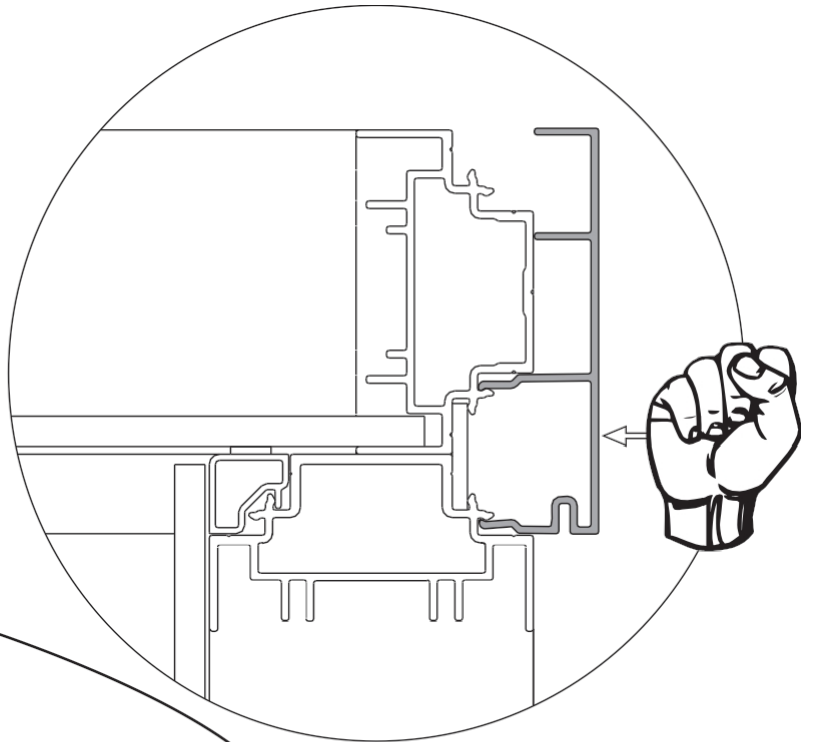
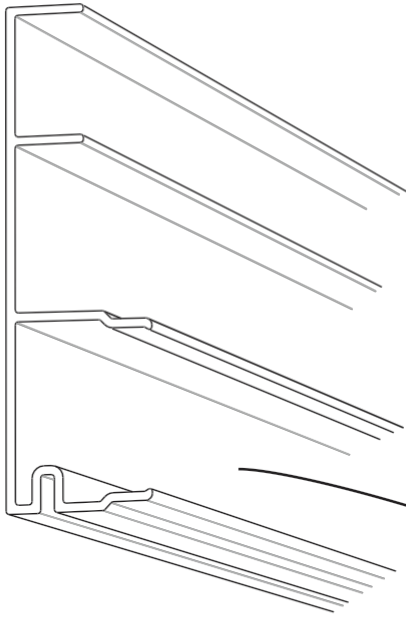

67

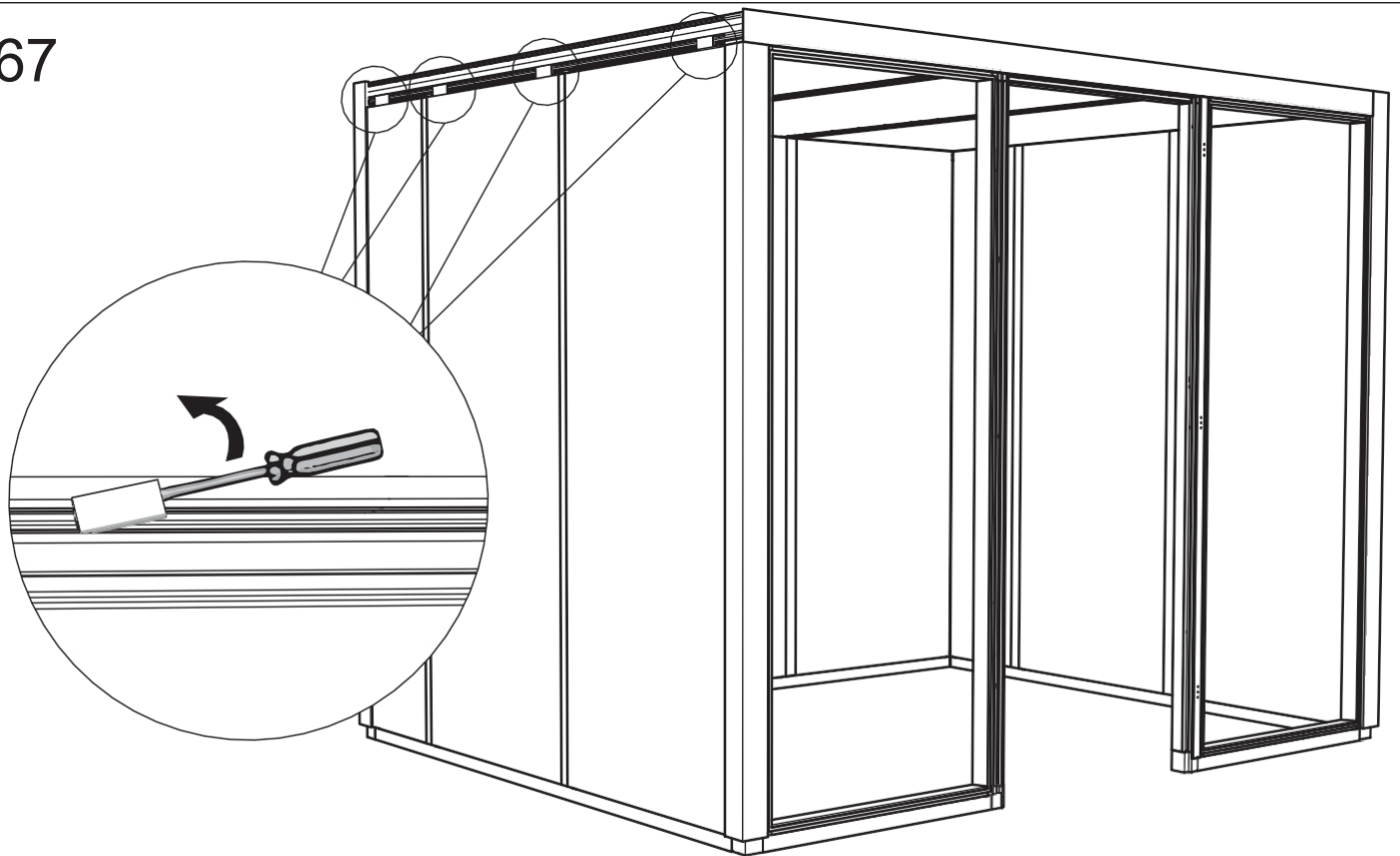

P4  
2046 mm

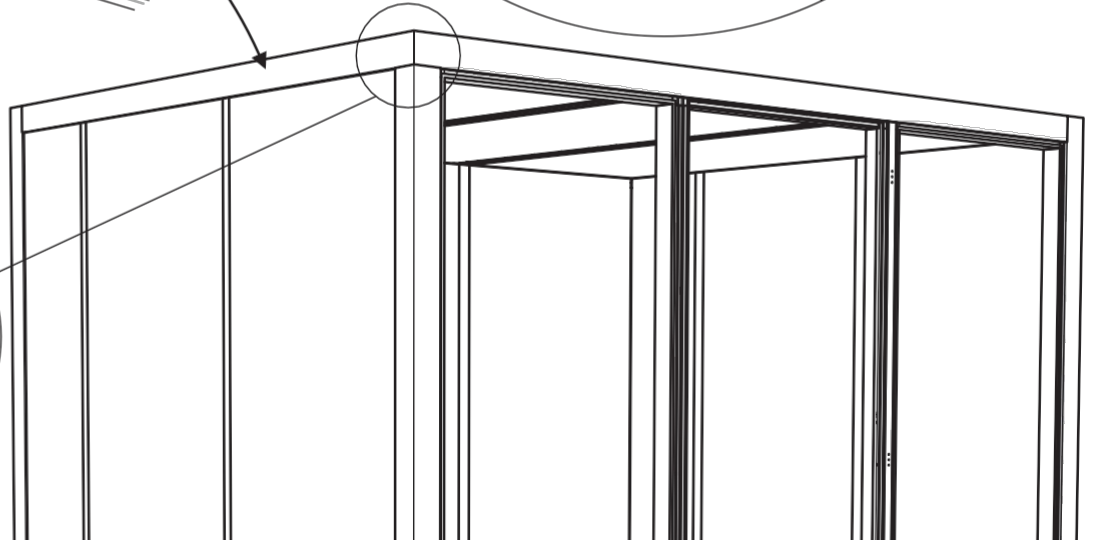
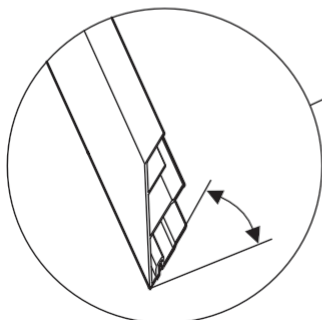
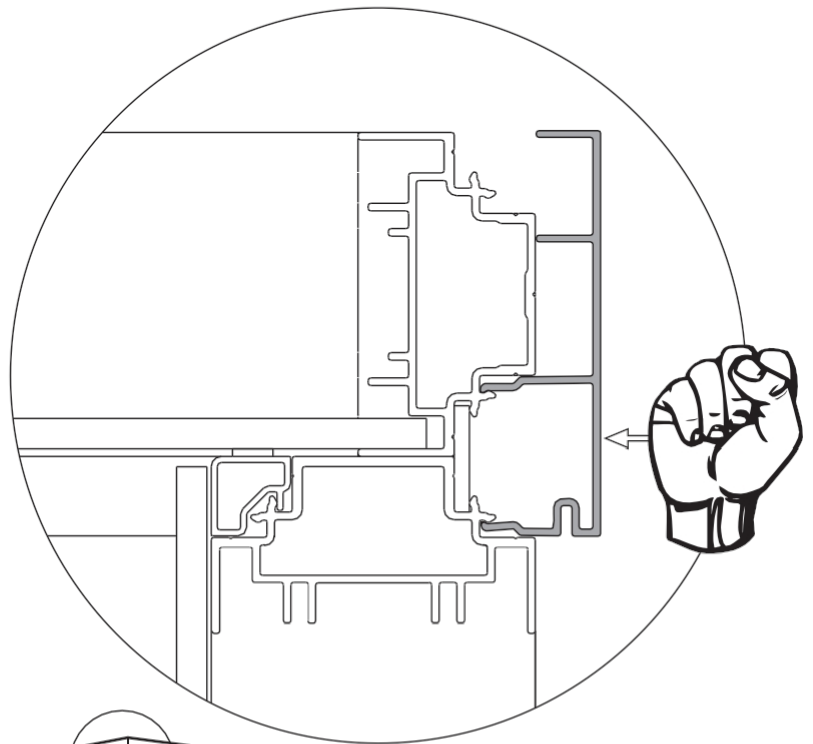
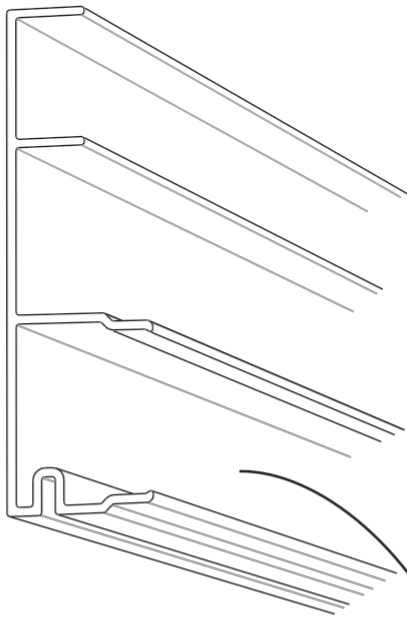

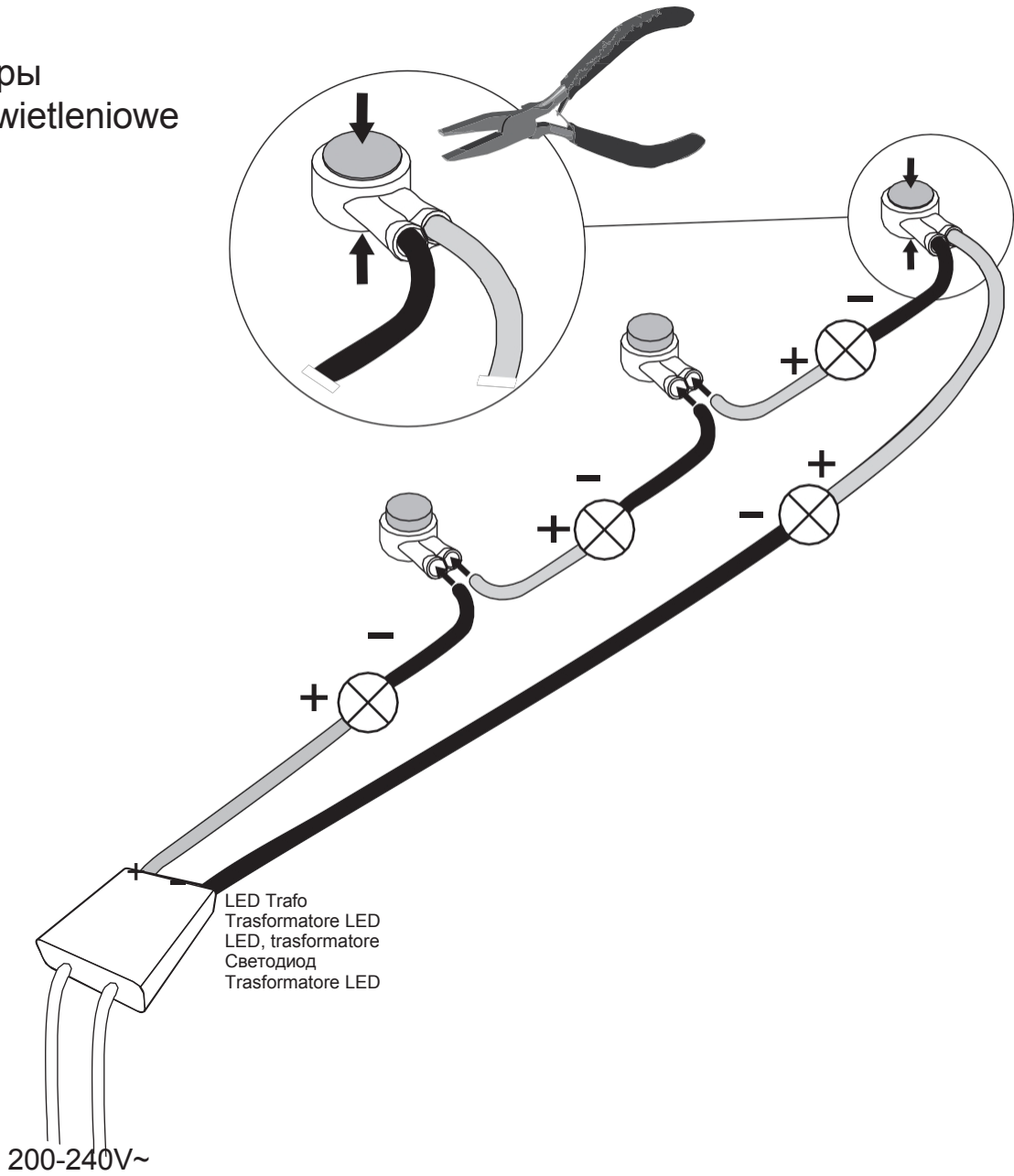

# 68

Riflettori  
 Riflettori  
 Прожекторы  
 Punkty oświetleniowe

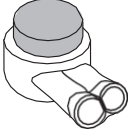

LED Trafo  
 Trasformatore LED  
 LED, trasformatore  
 Светодиод  
 Trasformatore LED

	Faretti	 	+	-
	Macchie Прожекторы Punkty oświetleniowe		Röd Rosso Rot Rouge Красный Czerwony	Svart Nero Schwarz Noir Чёрный Czarny

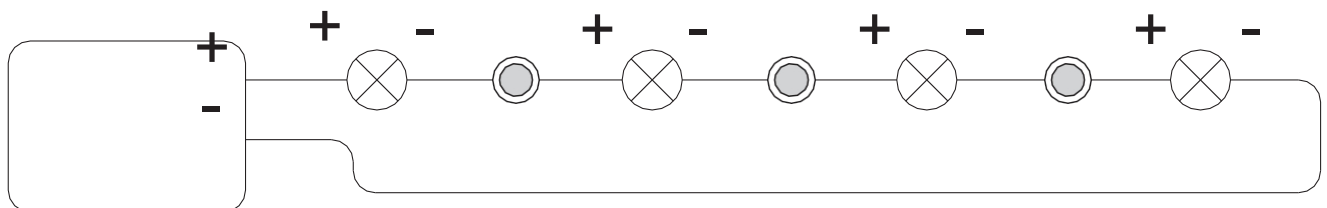

69

x1



x1

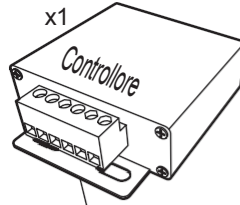

x1

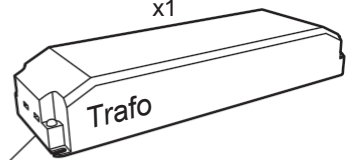

Vedere le istruzioni fornite con il telecomando a LED.  
 Vedere le istruzioni fornite con il controller remoto a LED.  
 Vedere le istruzioni fornite con il telecomando a LED.  
 Vedere le istruzioni fornite con il telecomando a distanza LED.

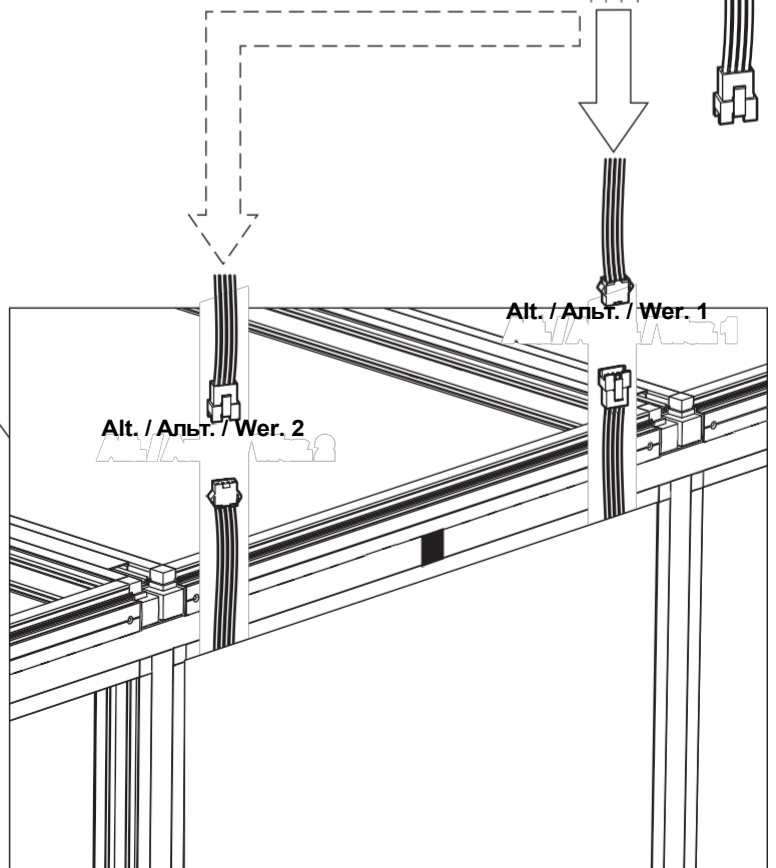
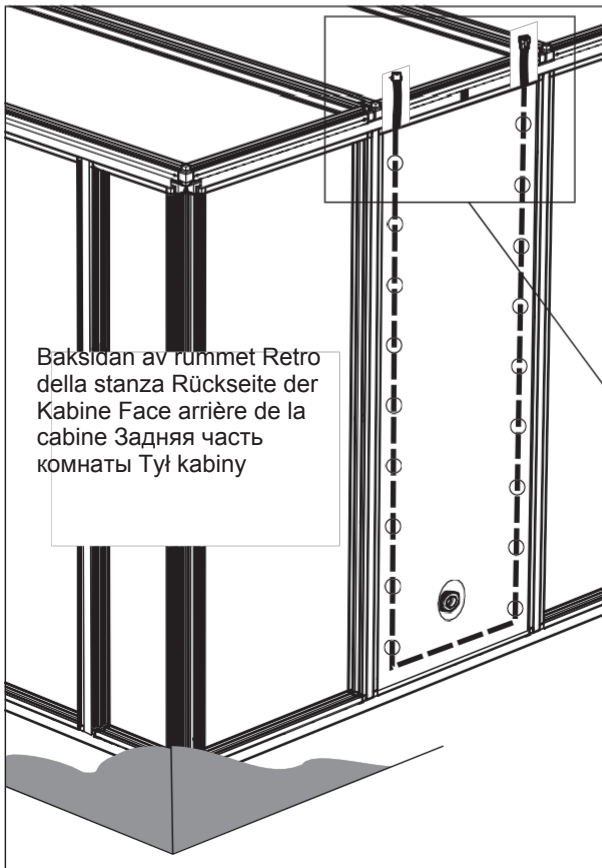
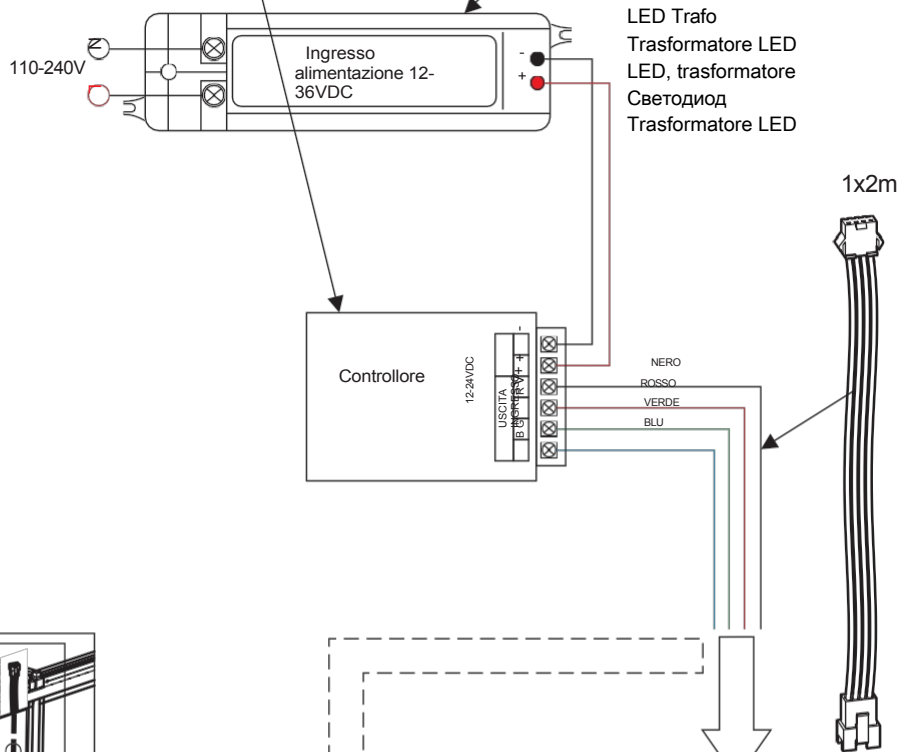
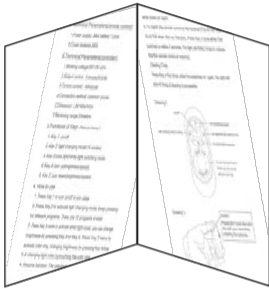

70

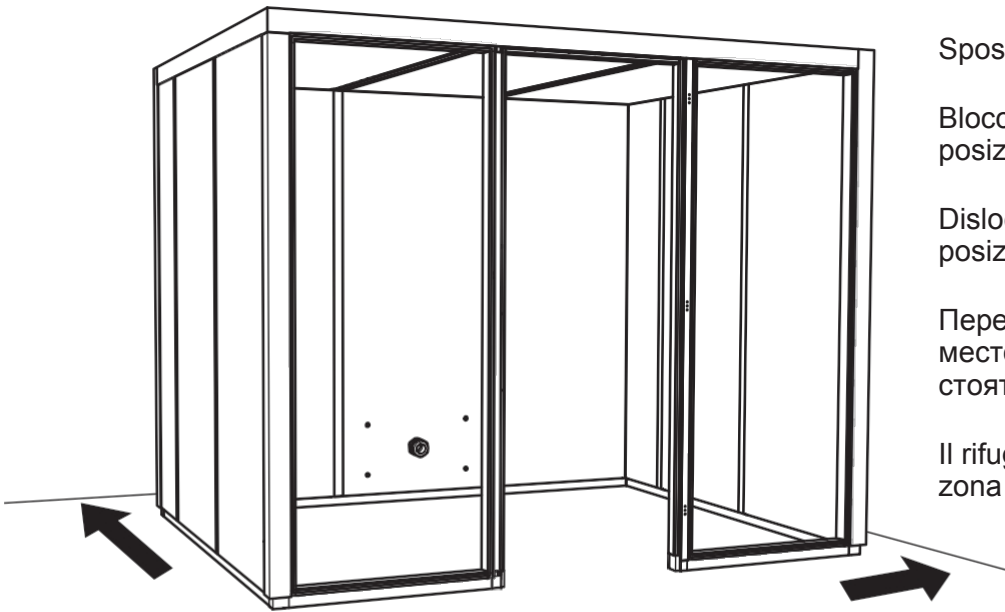

Far volare il rummet sulle piastre dove si trova.

Spostare il mobile in posizione.

Bloccare la cabina nella posizione desiderata.

Dislocare la cabina in una posizione definita.

Переместите комнату на место, где она должна стоять.

Il rifugio di Przesunąć si trova in una zona di montagna.

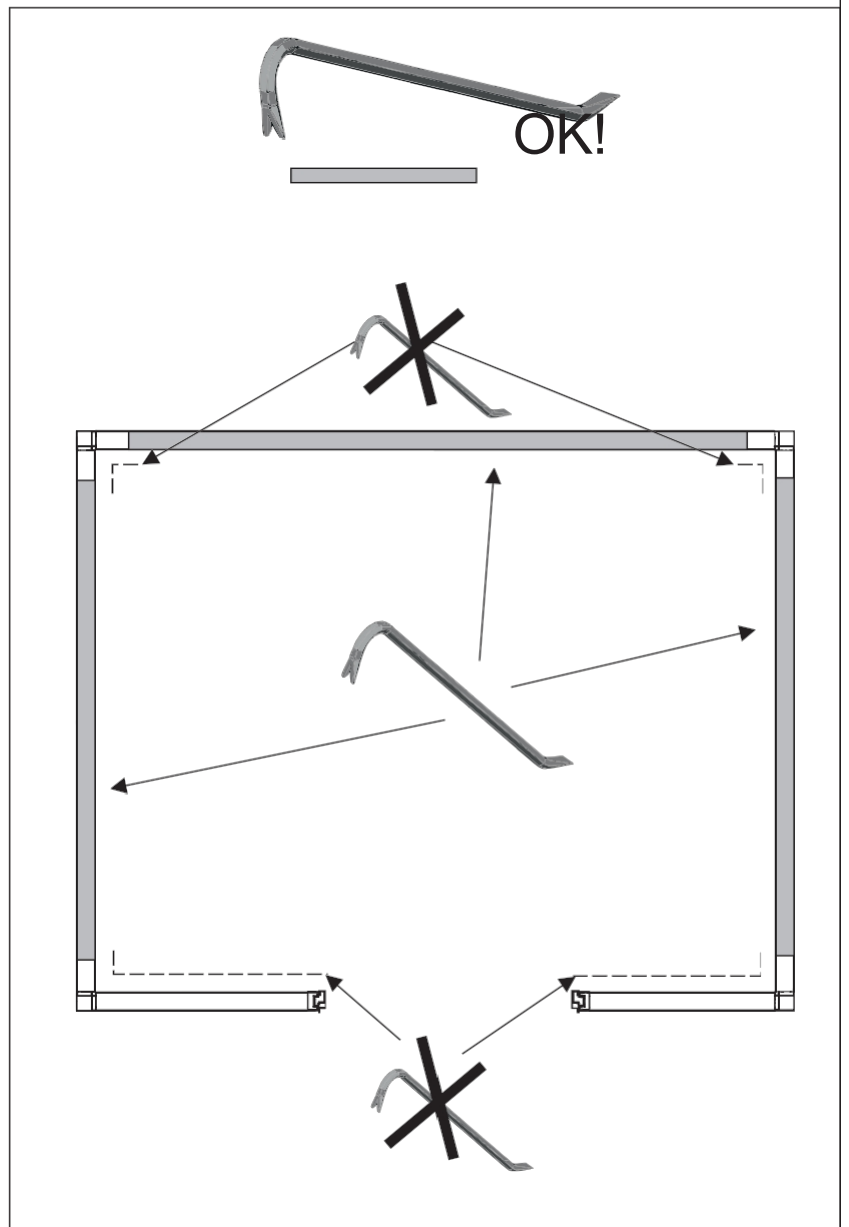
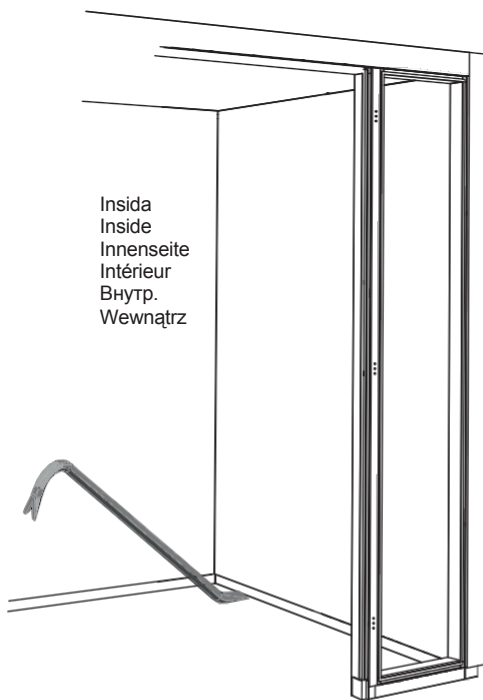

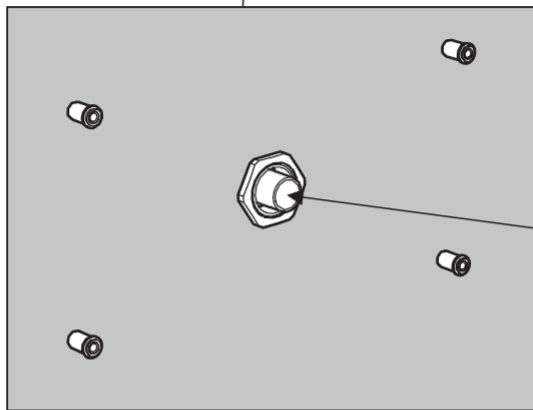
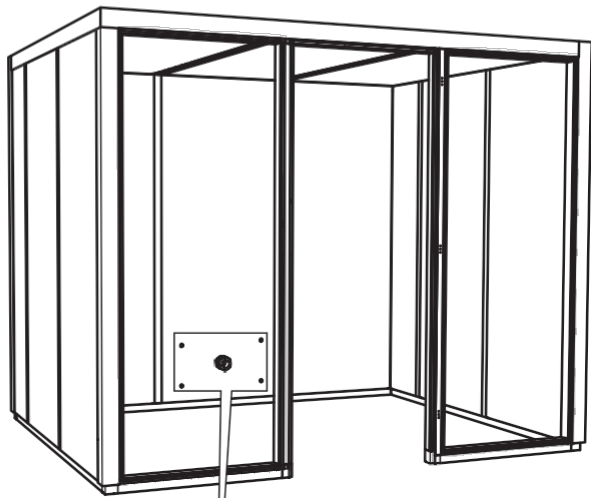
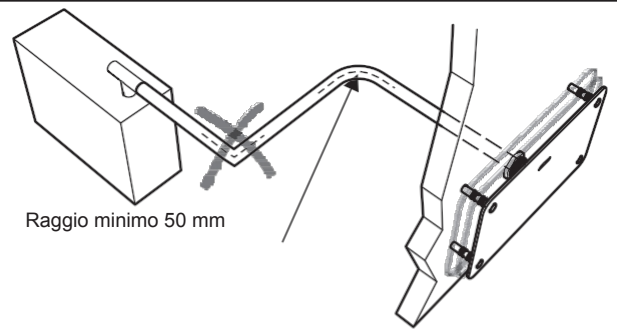

Isolamento  
Isolamento  
Värmedämmung  
Isolamento termico  
Термоизолирован  
Izolacja termiczna

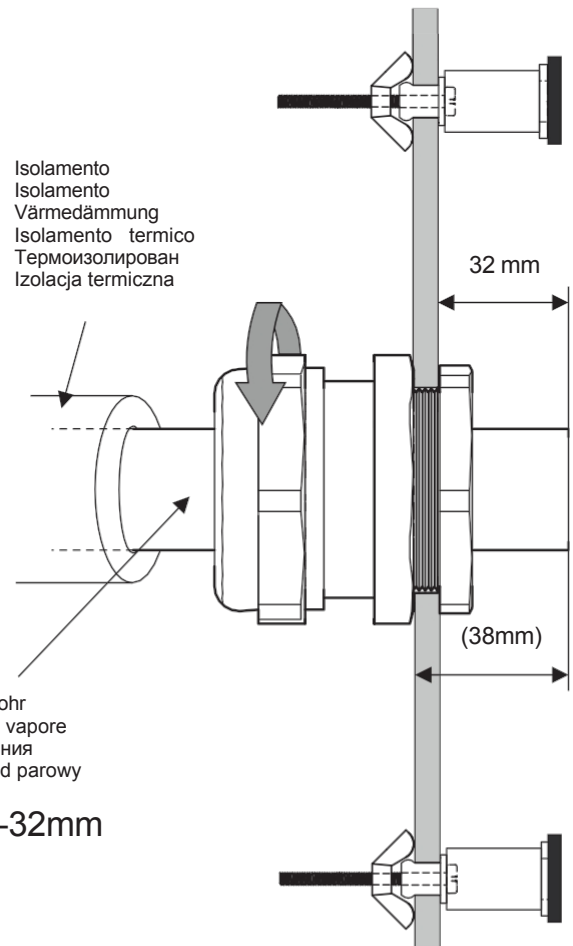

Tubo di  
vapore  
Dampfrohr  
Tubo di vapore  
Испарения  
Przewód parowy

Ø28-32mm

72

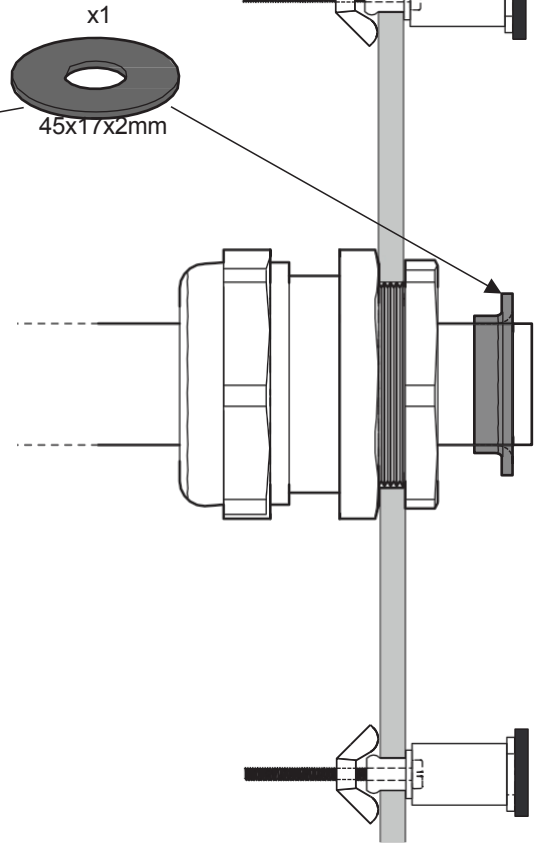
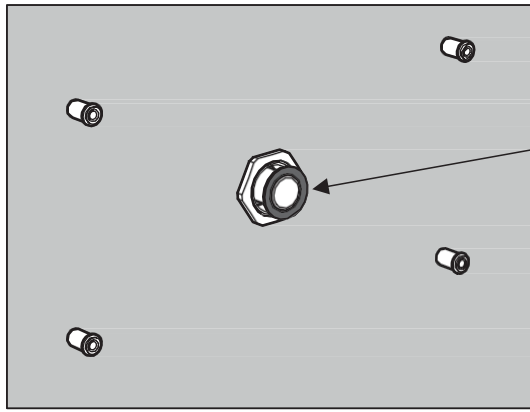

73

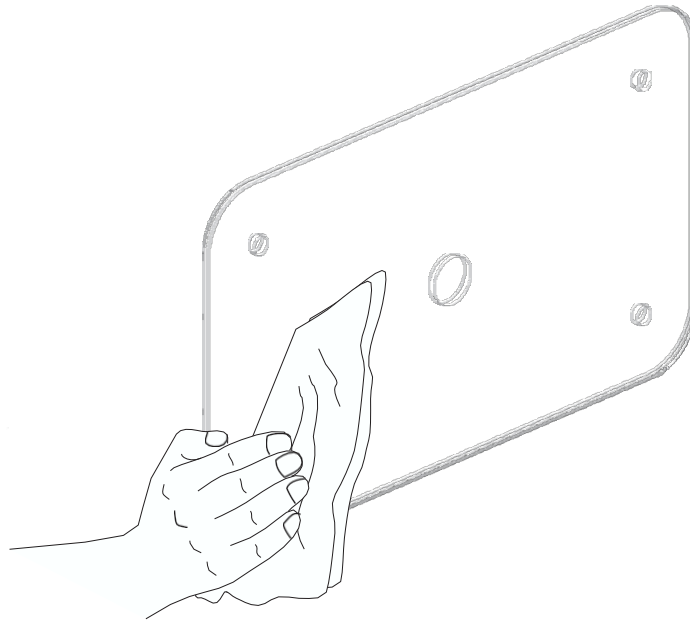

74

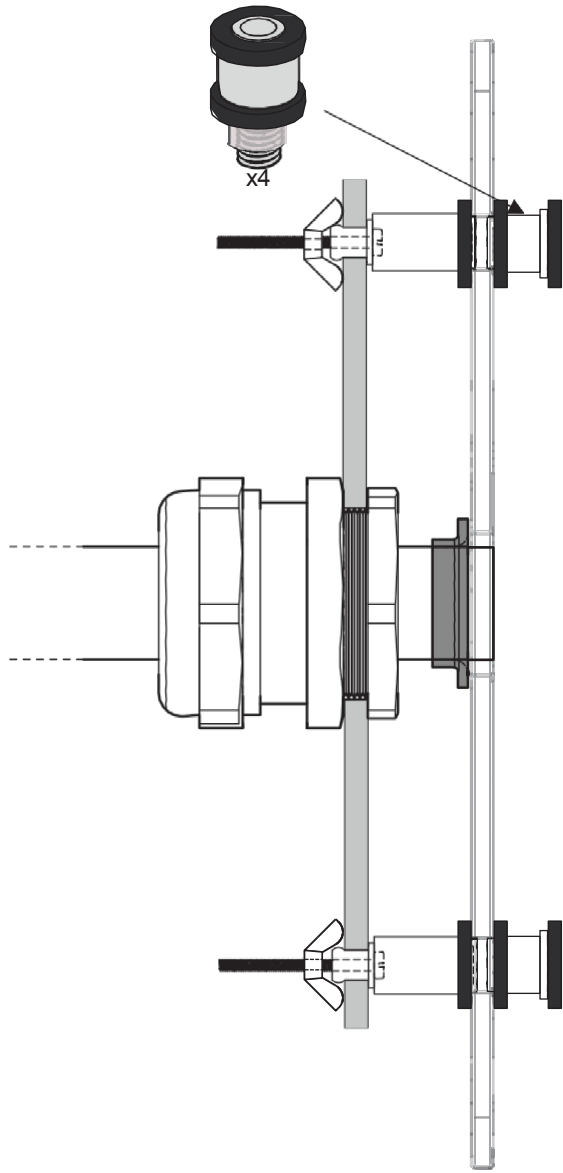

75

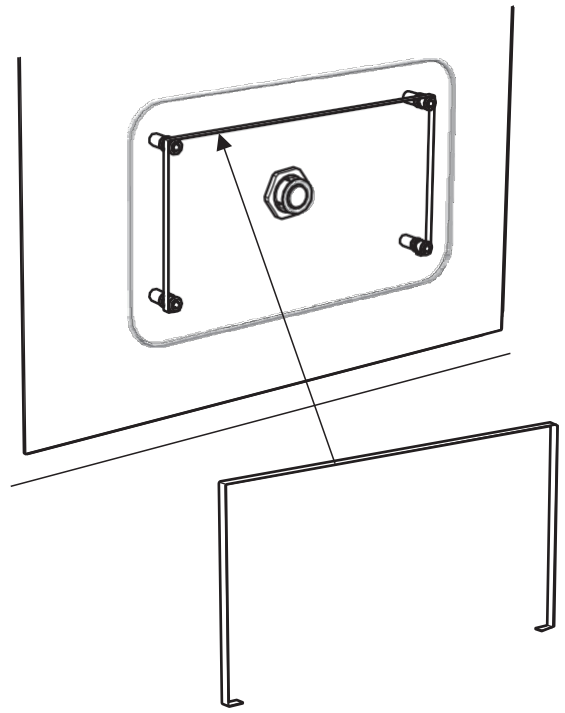

76

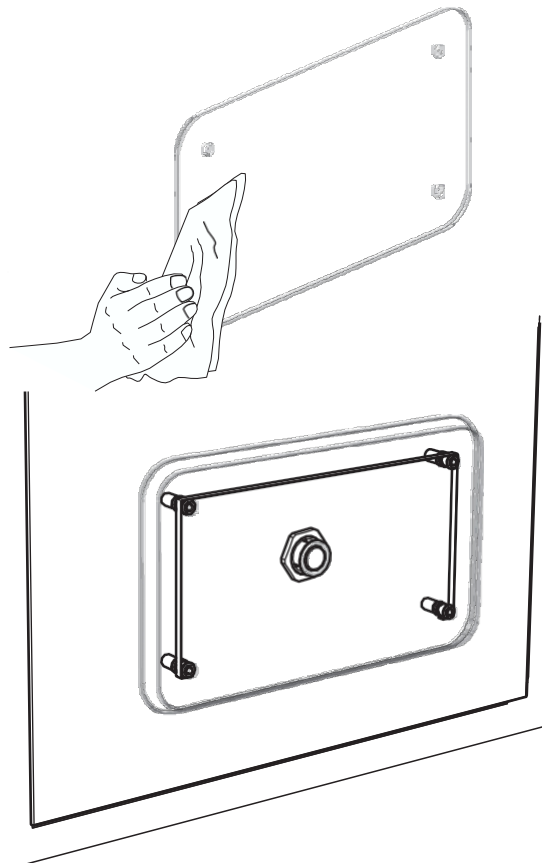

77

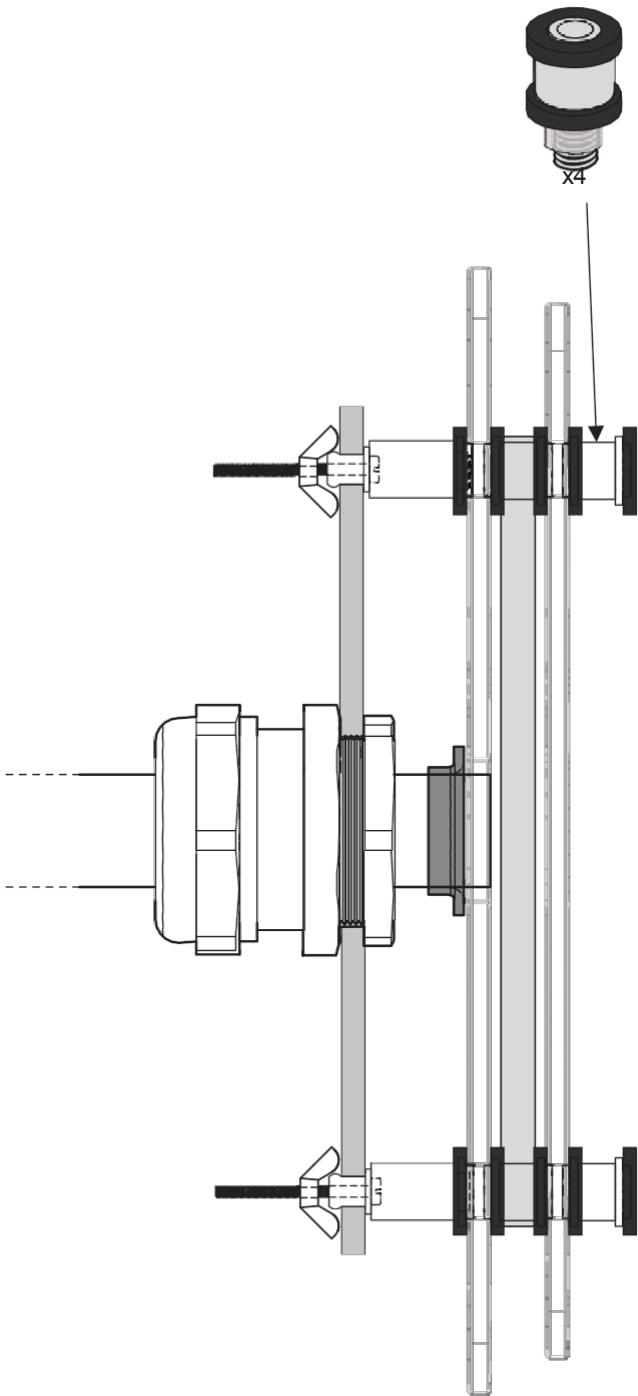

78

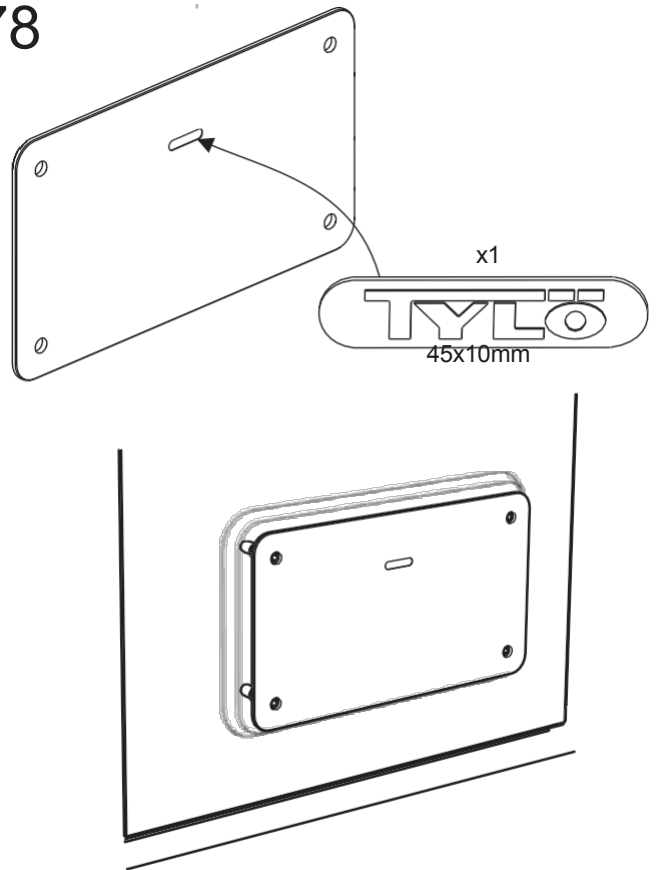

79

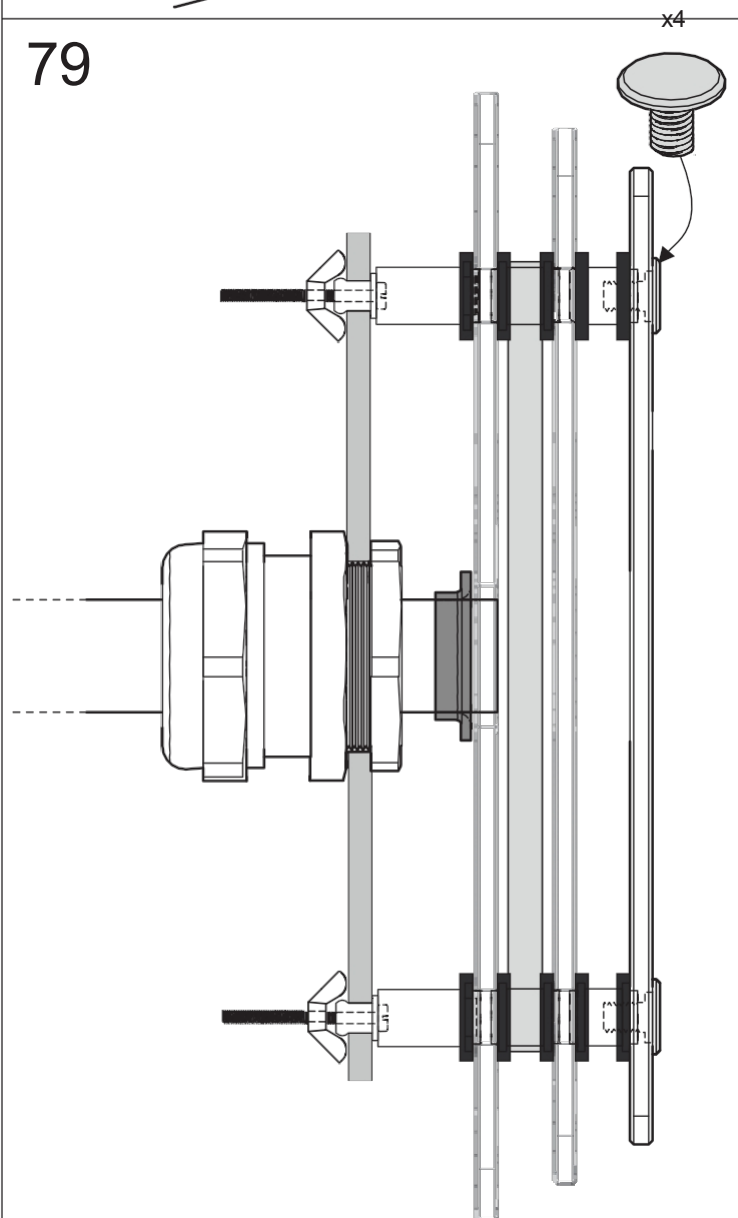

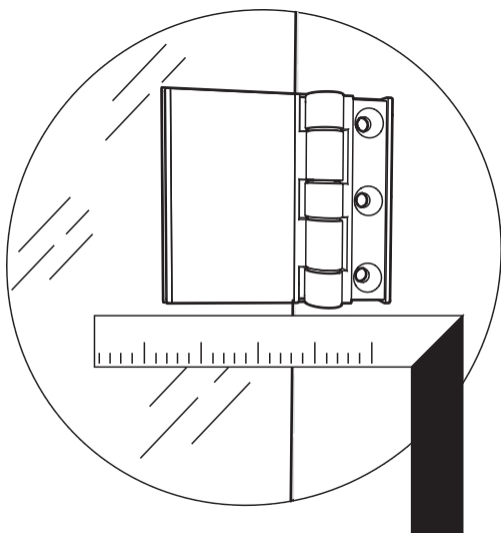

Utsida  
 Outside  
 Außenseite  
 Extérieur  
 Наруж.  
 Na zewnątrz

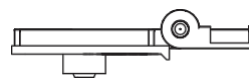

Insida  
 Inside  
 Innenseite  
 Intérieur  
 Внутр.  
 Wewnątrz



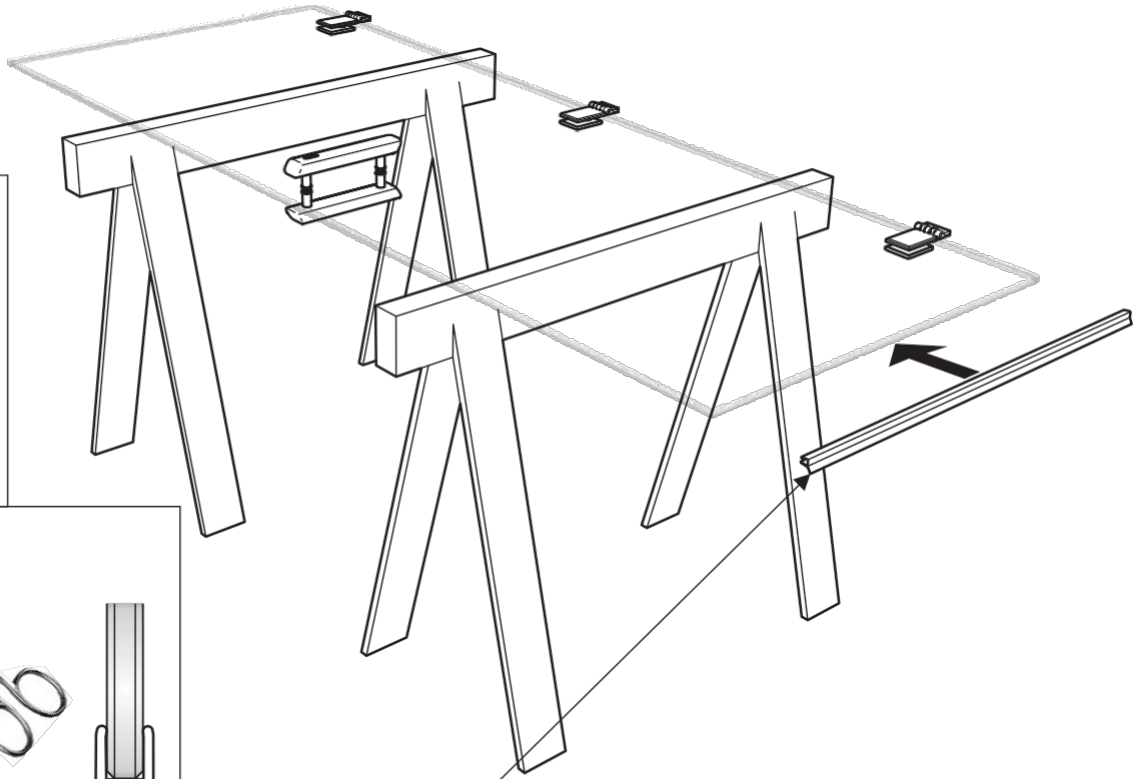

Alt. / Альт. / Вер. 1

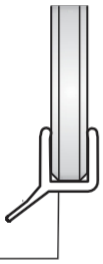

Alt. / Альт. / Вер. 2

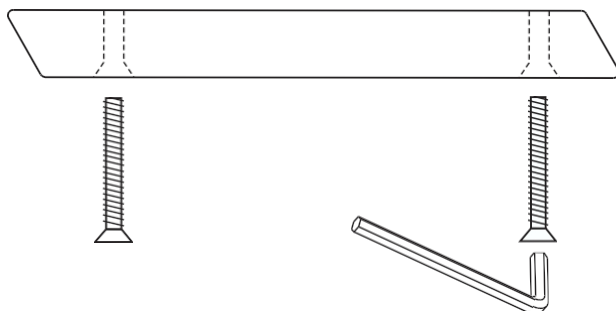
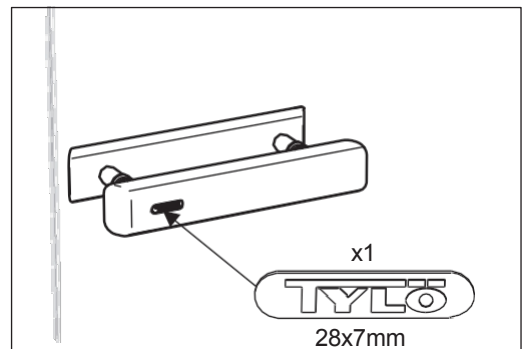
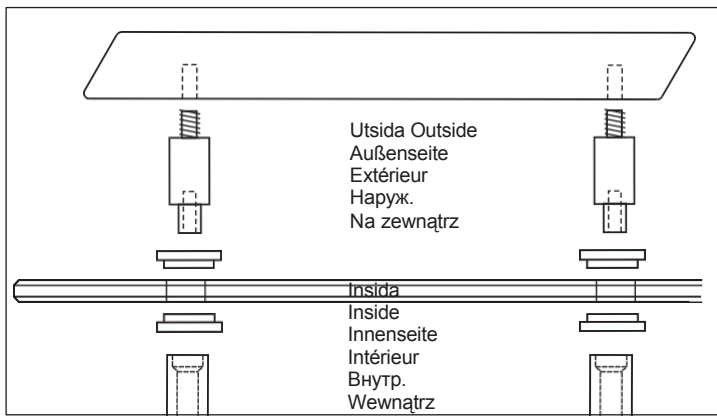
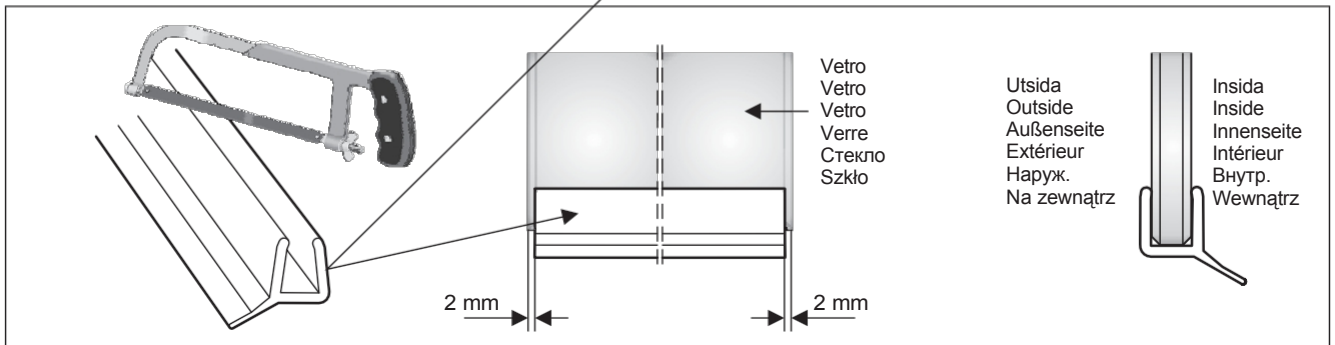
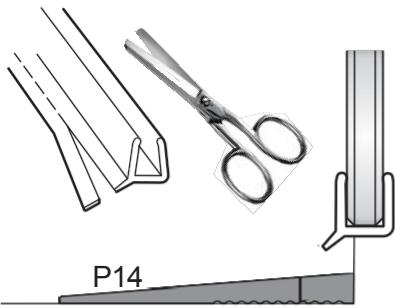

82

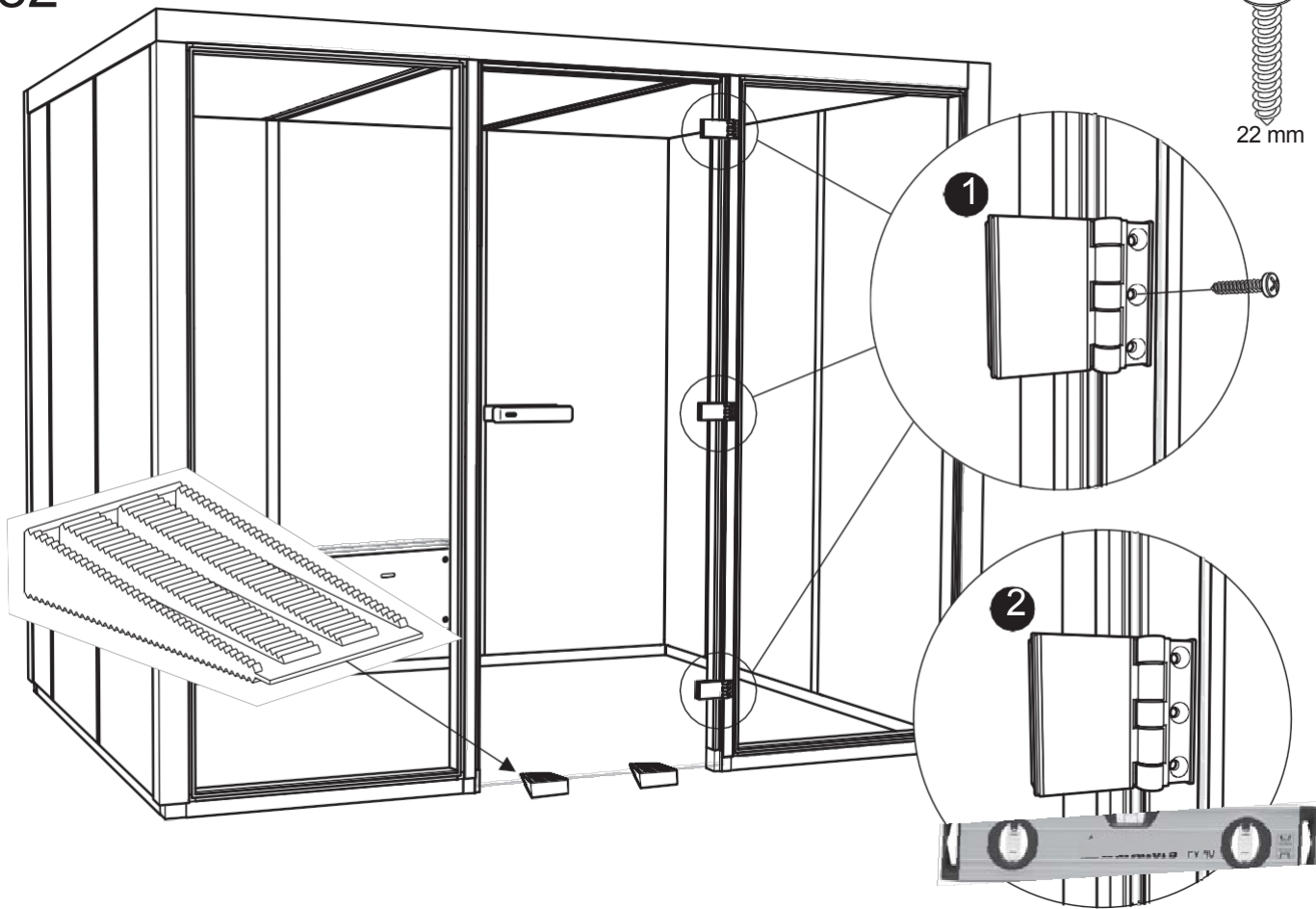

83

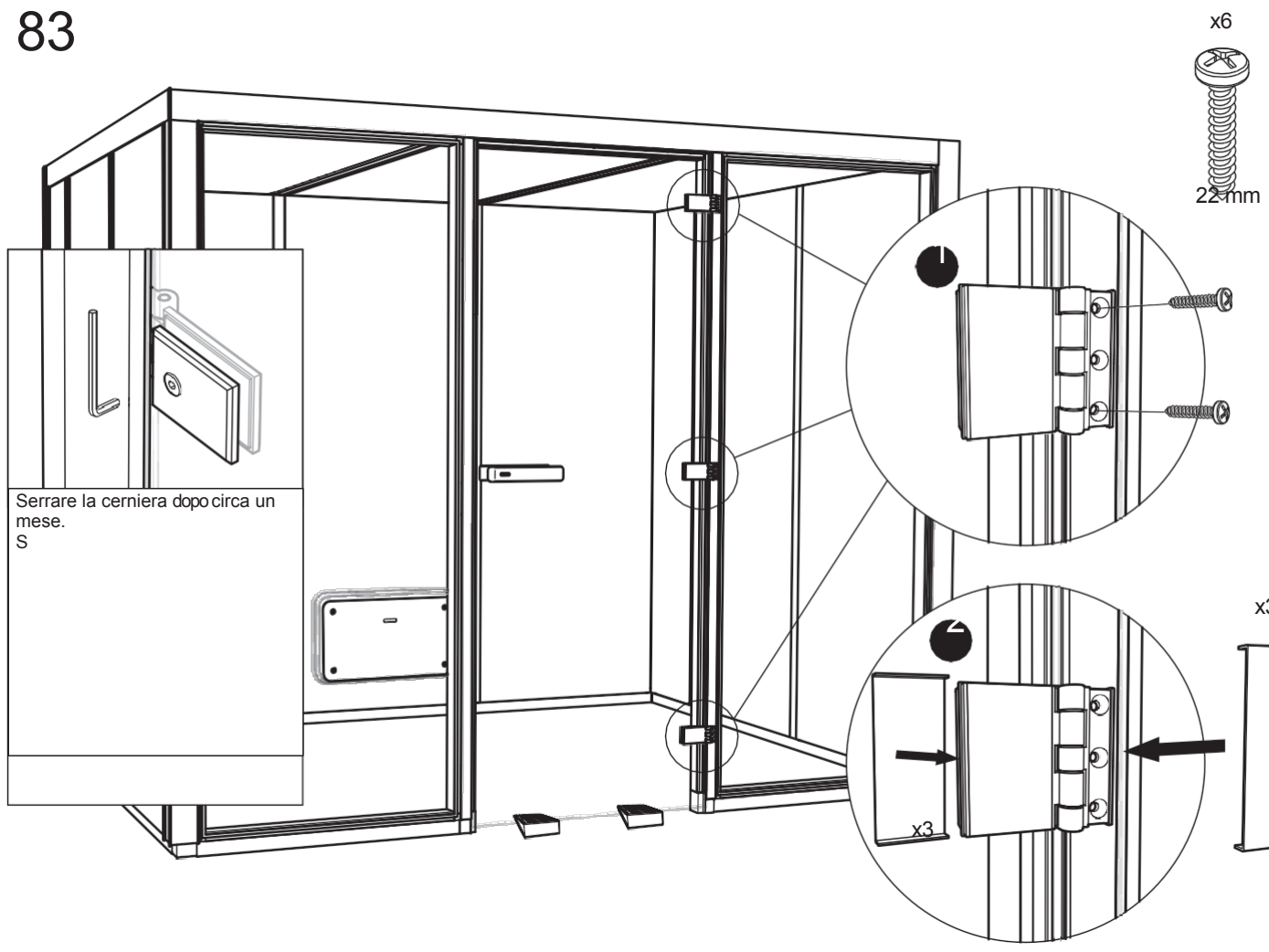

84

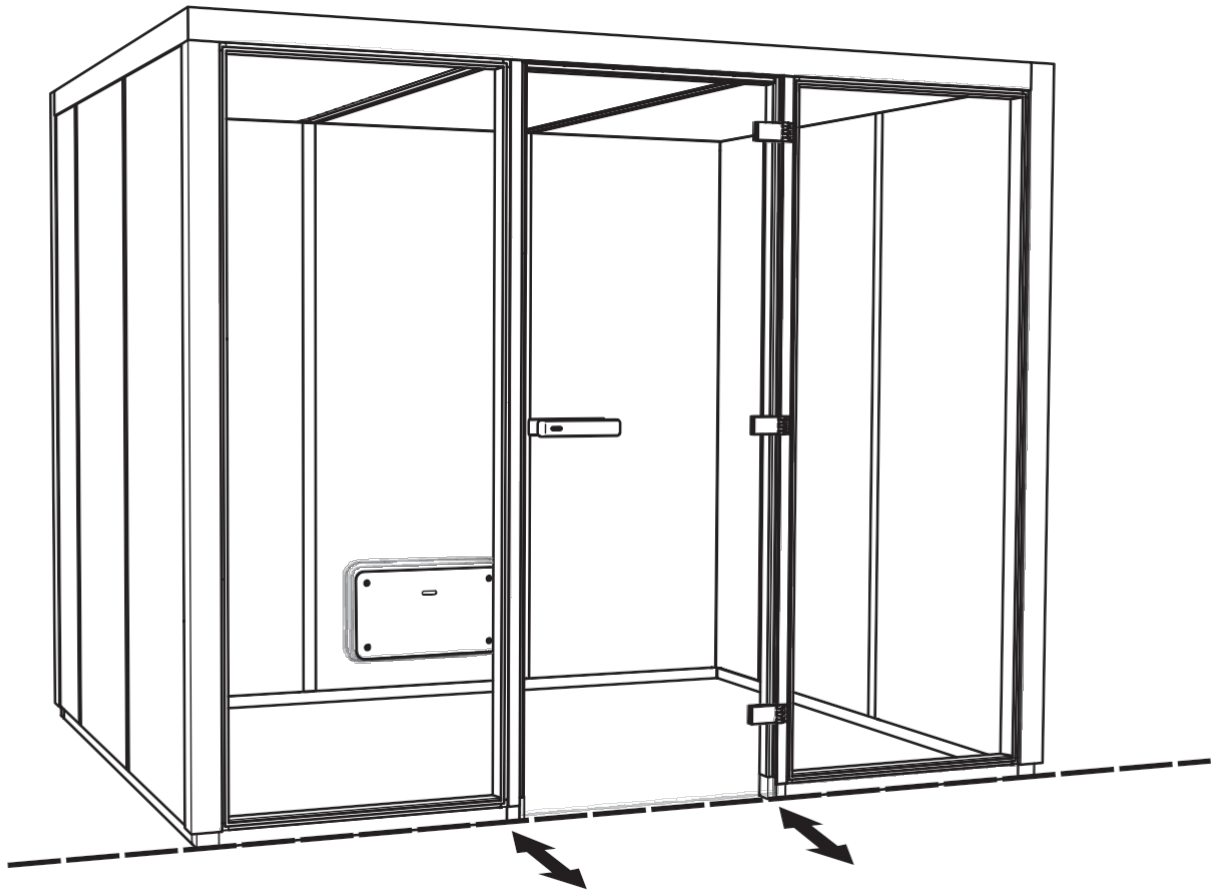

### 85 Alt. / Альт. / Wer.

